

Energy Management Solutions



Electricity information management
Logical control | Data backup record
Diversified I/O modules



Table of Contents

IIoT Power Meter Concentrator

1

Introduction and Features

ESG Introduction	P4
Energy Management Solutions	P6
PMC/PMD Power Meter Concentrator	P7
Cloud Management Software - IoTstar	P16

Energy Management Solution

2

Applications

Factory, Building, Public Place & Electricity Consumption of Machines P26



3

InduSoft P30

InduSoft Distributor (Taiwan, China)



4

PMC/PMD Power Meter Concentrator

Advanced IIoT PMC	P32
IIoT PMC	P37
IIoT PMC with Display	P46
IIoT iWSN PMC	P49



5

Smart Power Meter

PM Series Features and Selection Guide	P52
Smart Power Meter: LED Display/Three-phase/Single-phase/Multi-circuit	P54
EtherCAT Smart Power Meter Solutions	P75
PROFINET Smart Power Meter Solutions	P77
EtherNet/IP Smart Power Meter Solutions	P79

Fieldbus Gateway

EtherCAT



PROFINET



EtherNet/IP



Intelligent Power Meter



6

True RMS Input Module

8-channel True RMS Input Module P81

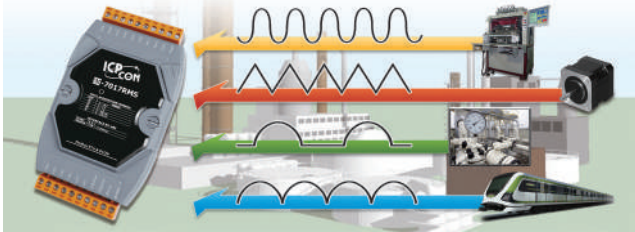

7

Voltage Attenuator and Current Transformer: DN-800 Series

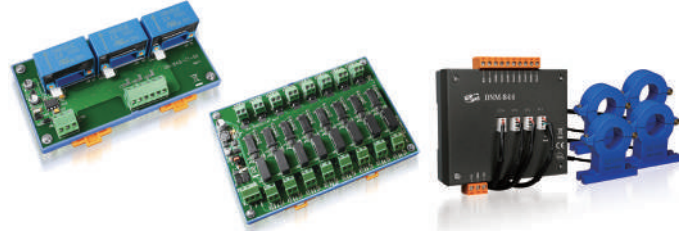

8

iWSN/iXN Solution

iWSN Data Concentrator/Sensing Module/Expansion Module/Power Meter P84

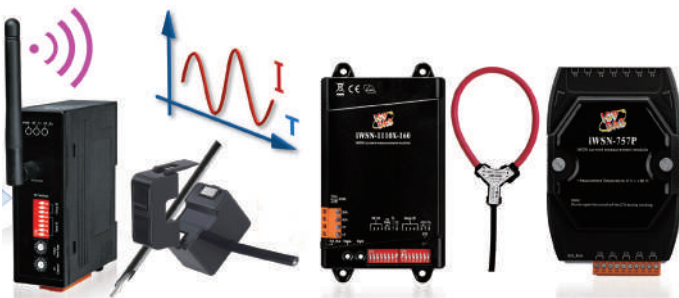

9

Infrared Thermography Temperature Monitoring

IR Temperature Data Concentrator & IR Temperature Sensing Module P94



10

Portable Power Monitoring Suitcase

..... P99



11

RPS-4M Redundant Power Supply

..... P100



Ch1. Introduction & Features

1.1 ESG Introduction

In recent years, businesses have been under pressure to undergo low-carbon and energy-saving transformations. ESG encompasses three main aspects: Environmental (E), Social (S), and Governance (G). Each of these aspects corresponds to specific ISO standards. Among these, three standards that most companies prioritize are: ISO 14064 that provides a complementary set of tools for programs to quantify, monitor, report and verify greenhouse gas emissions, ISO 14067 for product carbon footprint, and ISO 50001 for energy management systems.

Prior to implementing ESG, it is necessary to assess the current conditions of the factory and production lines. This involves establishing energy baselines and performance indicators. Conduct energy inventory and choose energy-intensive areas for data collection, statistical analysis, and assessment. Based on the analysis results, implement energy-saving strategies, focusing on the areas with high energy consumption. Finally, assess the outcomes to gauge their effectiveness and use this information to fine-tune further energy-saving approaches. ICP DAS offers a comprehensive solution that encompasses energy management, digital streaming, and edge computing to help businesses address challenges related to data acquisition, information collection, wiring deployment, and analytical processing. This comprehensive support enables companies to swiftly meet the requirements of ESG and green transformation.

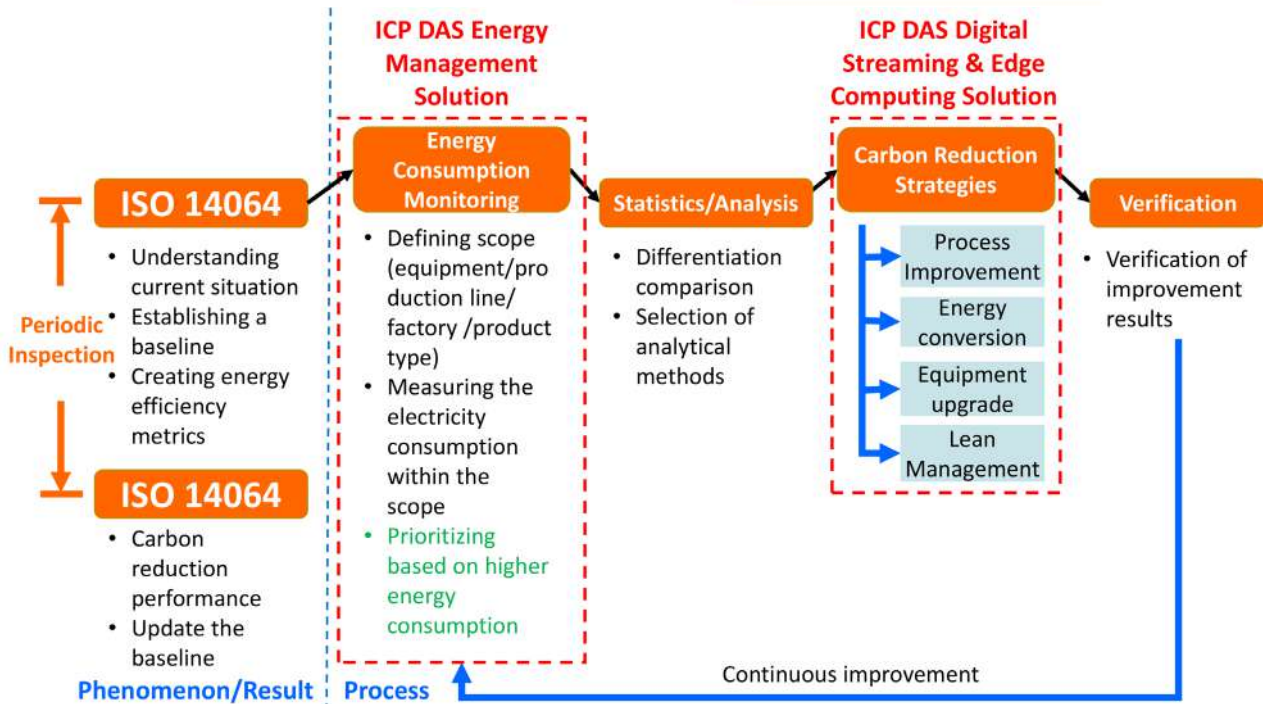

When businesses embark on projects for green transformation and energy saving, they encounter varying challenges across different domains. ICP DAS offers both wired and wireless smart meters and panel-mounted meters, wide range of industrial gateways and signal converters, various styles of distributed and centralized IO modules, as well as data collection servers in different sizes. These solutions provide an answer to energy consumption assessment and strategy implementation in various areas such as office buildings, server rooms, and production lines. Both existing facilities and new constructions can utilize these solutions to rapidly and accurately achieve tasks such as energy data collection, signal conversion, and strategy implementation.

ICP DAS not only provides various types of smart meters, panel meters, wired and wireless digital series modules, but also offers edge computing units, as well as upper-level command center visualization software and cloud-based applications.

Area	Issue	Approach
Office Building	<ul style="list-style-type: none"> Scattered equipment with lower energy consumption Lack of room for measurement devices Main energy consumption from air conditioning, lighting, or refrigeration 	<ul style="list-style-type: none"> Install power meters on main panels Consider issues regarding meter size, power information visualization, and energy consumption report generation Small decentralized devices can be easily installed on lightweight steel frames
Control Room	<ul style="list-style-type: none"> Existing meters lack communication function Meters have communication function but not in use Difficult wiring for meter communication lines Multiple power lines bundled, difficult to install CTs 	<ul style="list-style-type: none"> Use meters with communication interfaces Integrate with existing network by following meter communication protocols Use wireless communication to solve wiring issues Use flexible CTs to measure bundled power line
Production Line	<ul style="list-style-type: none"> Only main meters installed, unable to track individual equipment consumption Scattered equipment, high wiring costs Limited available space due to equipment occupying most of it Different run times for the same process on the machine, making baseline establishment difficult Difficulty obtaining power source for meters. 	<ul style="list-style-type: none"> Power meters are installed on site, costs on deployment and data storage space may be quite high. Use both wired and wireless communication to solve wiring issues. Saving space for not using a chassis, but may encounter issues with the fire sprinkler system Provide timestamps for power information Supply power to meters by voltage signal lines

When there are a large number of meters on-site, data from the meters can be aggregated and easily controlled through the edge controller. Historical trend chart display, energy-saving benefit analysis with bar charts, energy consumption breakdown with pie charts, real-time energy consumption information on dashboards, and the generation of daily and monthly energy consumption reports can all be achieved through web-based operations using the edge controller or SCADA software. Additionally, there is a 15-minute advance warning before energy consumption is about to exceed the contract capacity, allowing on-site personnel to take emergency actions.

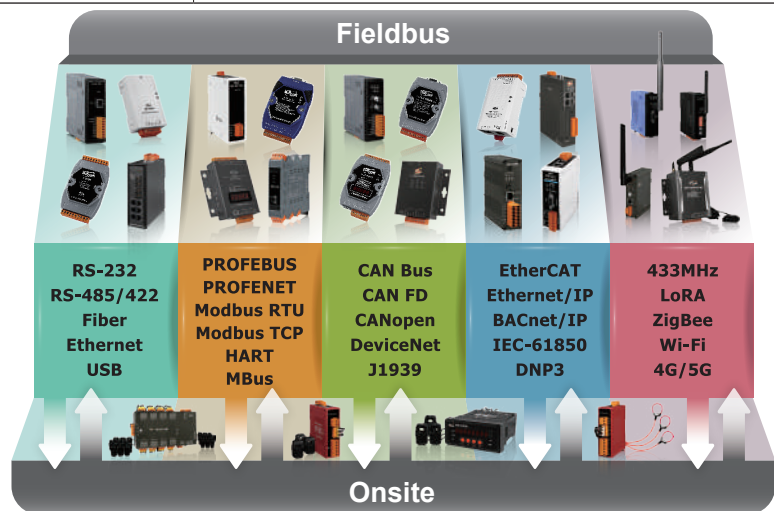

In terms of cloud management, IoTstar is suitable for scenarios where a large amount of data and devices need to be managed. It can be easily deployed on mainstream cloud servers and allows for web-based management of edge controllers and smart meters. In addition to remote firmware updates, it can store a large amount of data in various databases. When a device disconnects, historical data can be retrieved through FTP to fill in missing data.

In the event of an alarm, IoTstar supports real-time communication software, enabling the creation of two-way interactive real-time monitoring functions on mobile phones. This allows for immediate understanding of the alarm situation and the ability to take emergency actions remotely.

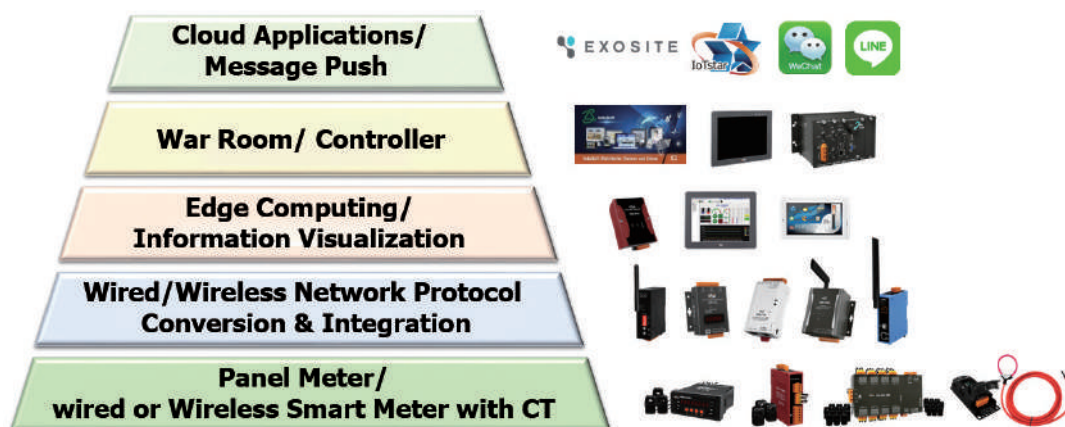

1.2 Energy Management Solutions

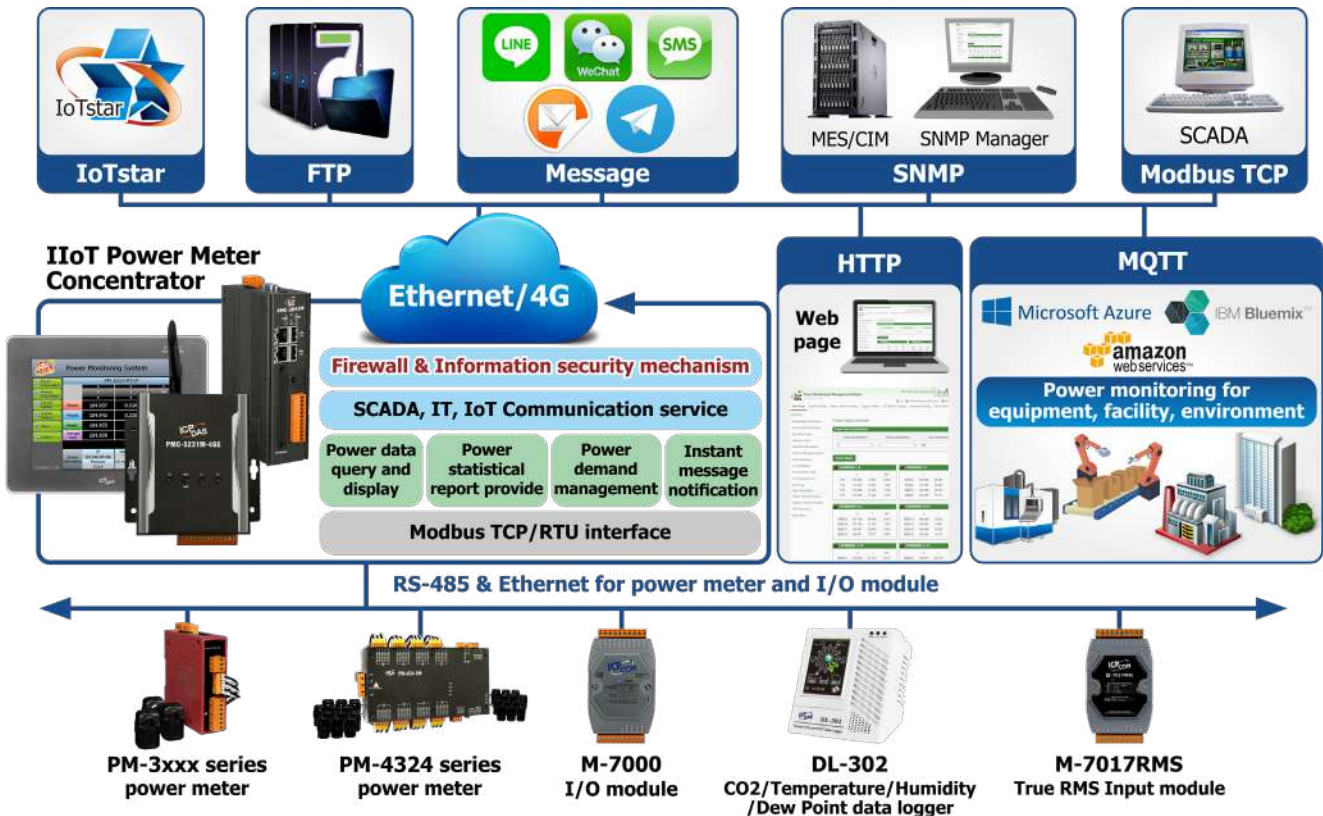

The PMMS energy management solution provided by ICP DAS includes: Power Meter, Power Meter Concentrator(PMC/PMD), and Back-end software (such as: IoTstar Cloud Management Software, InduSoft SCADA Software). In addition to provide users hardware device, ICP DAS is also a complete One-Stop shop solution provider to help user to easily and quickly set up a power monitoring system. Based on PMMS solution, users can review the power consumption status of machine, equipment, and facility, and as the basis for making decision to adjust the operation in real time to effectively achieve the goal of energy saving and carbon reduction and optimize the maximum benefit of system. During the early stage, if the scale of the application is small, user could simply use Power Meter and PMC/PMD to set up a simple power monitoring system, once the scale of the application is expanded, the user could get the back-end software involved and build an easy-to-expand power monitoring system via blocks stacked structure. By this way, the PMMS solution will be highly flexible and could be implemented in phases to meet various requirements, so it is the best energy management solution under the company's ESG sustainable development goals.

1.3 PMC/PMD Power Meter Concentrator



Features

- No extra software tool, using browsers to perform system operations

Featuring web-based interface for easy operations, the user could connect to PMC/PMD webpage via browsers to review the power data, set up system setting, manage power demand and perform logic rule setting for alarm notification.

Power Data Classification

Data Classification1	Data Classification2	Data Classification3
V	I	kW

Power Meters

外區廊道插座 1~4

	V	I	kW
CT1	111.925	3.750	0.411
CT2	111.925	13.000	1.421
CT3	111.565	17.940	1.933
CT4	111.565	11.043	1.137

外區廊道插座 5~8

	V	I	kW
插迴(5)	109.530	31.940	3.269
插迴(6)	109.530	26.727	2.729
插迴(7)	111.100	37.960	4.007
插迴(8)	111.100	20.692	2.203

外區廊道插座 9~12

	V	I	kW
插迴(9)	105.751	19.137	1.927
插迴(10)	105.751	14.707	1.506
插迴(11)	106.655	25.638	2.537

外區廊道插座 13~16

	V	I	kW
插迴(13)	108.811	10.015	1.016
插迴(14)	108.811	8.267	0.873
插迴(15)	107.968	12.431	1.295

■ Display real-time or historical power data

In addition to display power data of the power meter in text format, the power data can also be displayed in real-time and historical trend chart for user to easily identify the variation of the electricity usage of the devices.

Power Data Information

Overview Group Overview

Data Classification: Daily Accu. Electricity

Power Meter List	CT / Phase A	CT / Phase B	CT / Phase C	CT / Total
Air Conditioner	12.908	23.135	29.959	19.683
Refrigerator	53.767	42.163	65.376	160.762
Electric Light(Submeter1)	32.052	21.458	42.878	95.845
Electric Light(Submeter2)	31.797	20.192	43.889	95.74
Electric Light(Submeter3)	32.089	19.26	45.487	106.411
Electric Light(Submeter4)	32.413	18.265	47.077	83.669
Electric Light(Submeter5)	32.744	17.29	47.606	95.252
Electric Light(Submeter6)	33.205	16.374	50.321	95.372
Electric Light(Submeter7)	33.347	15.351	51.957	107.741
Electric Light(Submeter8)	33.586	14.368	53.62	82.981

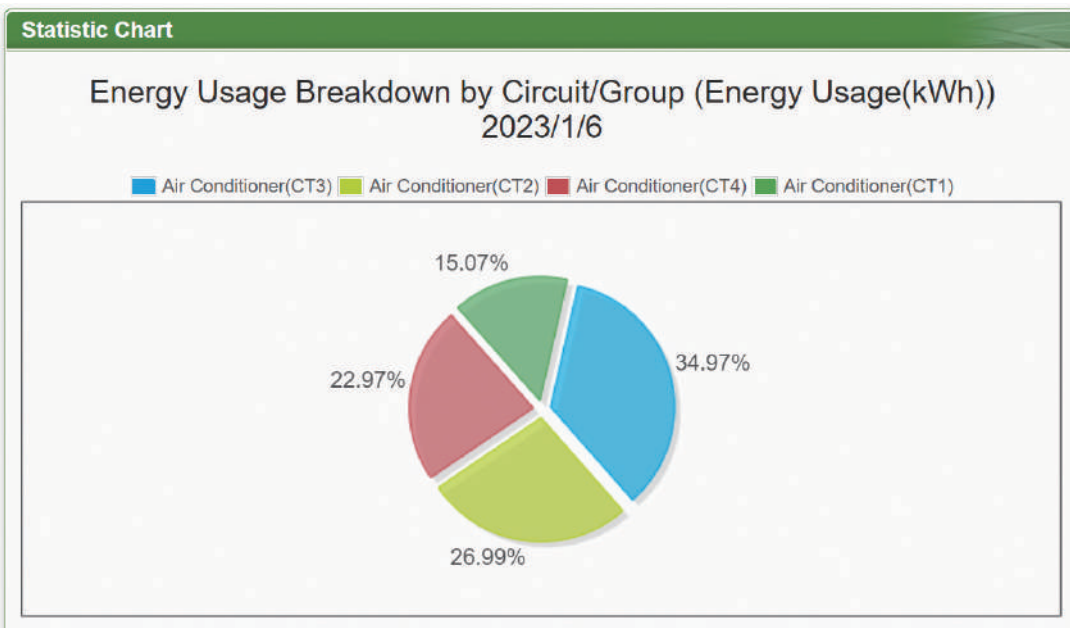
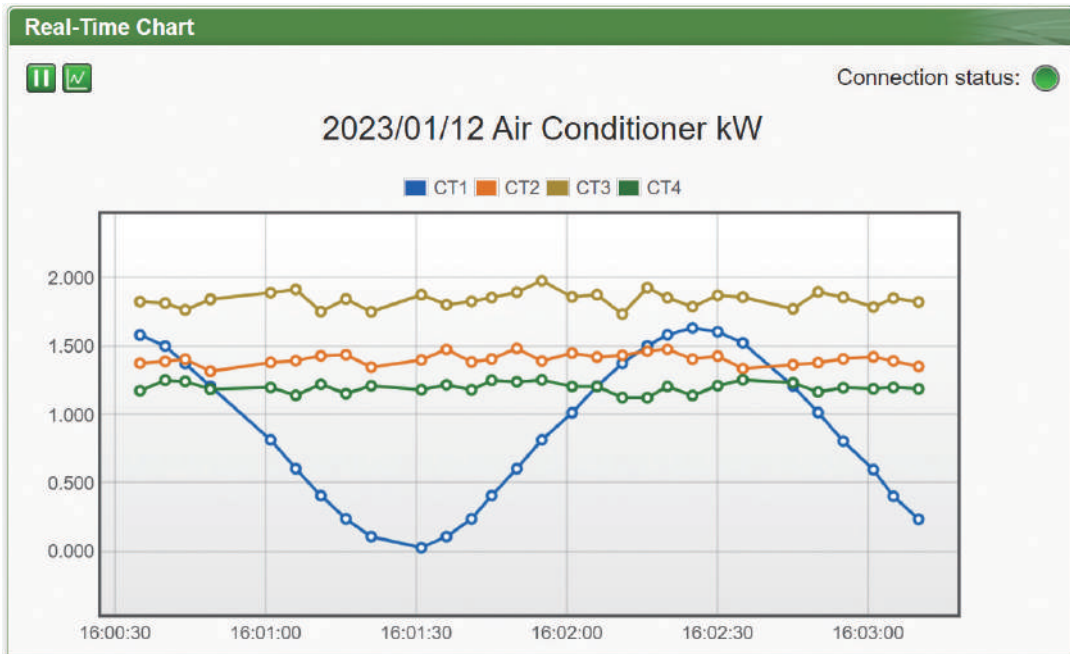

■ Support power data recording, storage and data file send back (provide data file recovery mechanism)

The PMC/PMD features a built-in Micro SD card to save the power data which PMC/PMD retrieve from power meter and regularly send back the data files to the backend management center for data analysis and statistics. In addition, PMC/PMD also offers a complete data file recovery mechanism so that when experiencing network disconnection, the data log files will be recovered after the network is resumed to ensure the system operates properly.

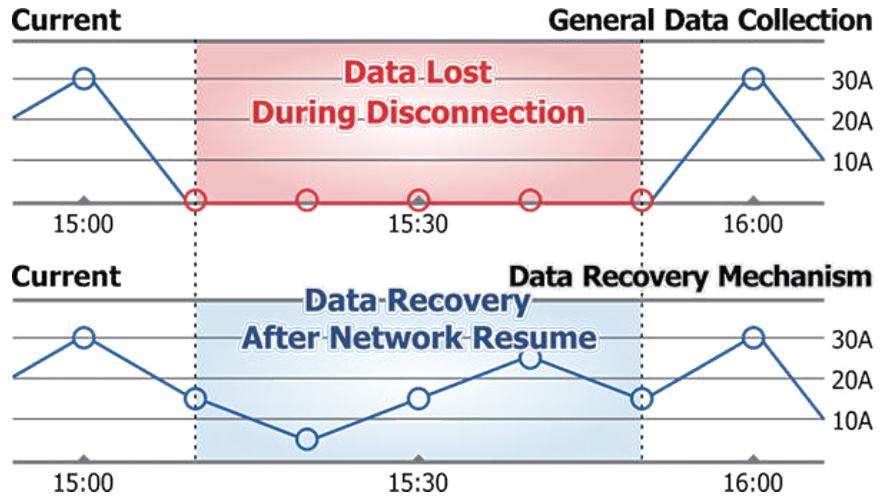

■ Provide power data statistics report

PMC/PMD provides historical data report inquiry and display function, the easy-to-read report of the historical power data would help to understand current electricity usage of the equipment.

Central Air Conditioning - Monthly Report											
Report Date: 2015-08											Print Date: 2015-11-11
Date	Max. Demand(kW)	kWh(kWh)	Avg. PF(%)	I _a (A)	I _b (A)	I _c (A)	V _a (V)	V _b (V)	V _c (V)	kVA Tot.(kVA)	kvar Tot.(kvar)
1	4.934	117.189	94.2	15.498	13.494	17.494	111.497	110.497	112.506	5.183	1.72
2	4.934	117.223	94.3	15.499	13.493	17.495	111.499	110.51	112.495	5.183	1.718
3	4.938	117.219	94.3	15.499	13.495	17.493	111.499	110.505	112.499	5.183	1.716
4	4.938	117.188	94.3	15.499	13.495	17.494	111.503	110.498	112.492	5.183	1.719
5	4.93	117.213	94.3	15.499	13.494	17.494	111.5	110.506	112.501	5.183	1.719
6	4.934	117.189	94.2	15.499	13.496	17.494	111.494	110.493	112.498	5.183	1.72
7	4.935	117.207	94.3	15.498	13.494	17.493	111.498	110.496	112.501	5.183	1.718
24	4.93	117.215	94.3	15.498	13.493	17.494	111.495	110.502	112.498	5.183	1.718
25	4.938	117.211	94.3	15.499	13.493	17.494	111.498	110.514	112.49	5.183	1.719
26	4.938	117.197	94.2	15.498	13.494	17.493	111.496	110.511	112.5	5.183	1.72
27	4.938	117.213	94.3	15.499	13.494	17.495	111.498	110.519	112.5	5.184	1.718
28	4.93	117.203	94.3	15.499	13.495	17.494	111.5	110.494	112.5	5.183	1.719
29	4.93	117.221	94.3	15.498	13.493	17.494	111.493	110.494	112.485	5.183	1.716
30	4.943	117.211	94.3	15.499	13.493	17.495	111.499	110.5	112.512	5.183	1.718
31	4.938	117.211	94.3	15.498	13.495	17.494	111.499	110.501	112.5	5.183	1.718
Total Electricity		3633.401 kWh	Monthly Highest Usage		5.625 kW		Occurrence Time 2015/8/14 10:14				

■ Provide "Power Usage Effectiveness (PUE)" calculation operation

Power usage effectiveness(PUE) is a measure of how efficiently a computer data center uses energy; specifically, how much energy is used by the computing equipment (in contrast to cooling and other overhead). The lower PUE value, means the higher of the greening degree of a data center. Using PMC/PMD with ICP DAS power meter to set up a power monitoring system allows user to review the PUE value through the webpage, thereby evaluate the efficiency of energy usage of the data center.

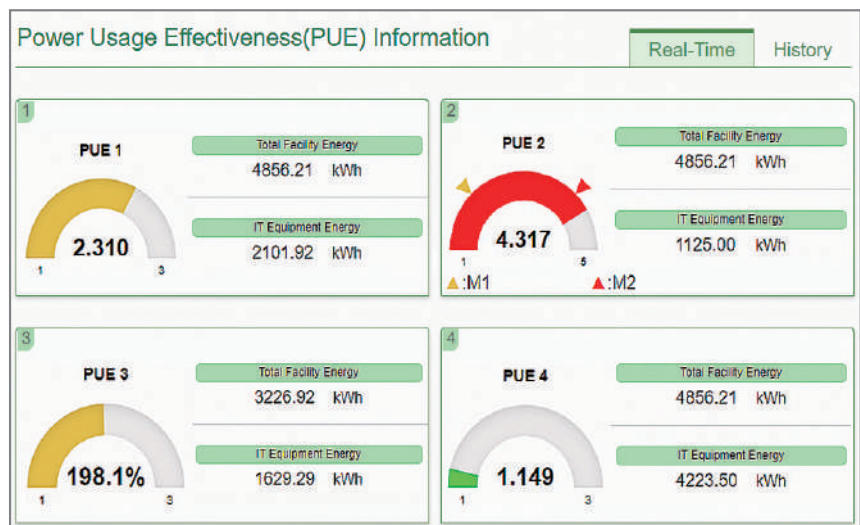

■ On-Site Power data viewing and system setting

PMD (Power Meter Concentrator with Display) series is equipped with TFT LCD (with Touch Panel). It provides an easy way for viewing the power data and set up the system parameters on sites.

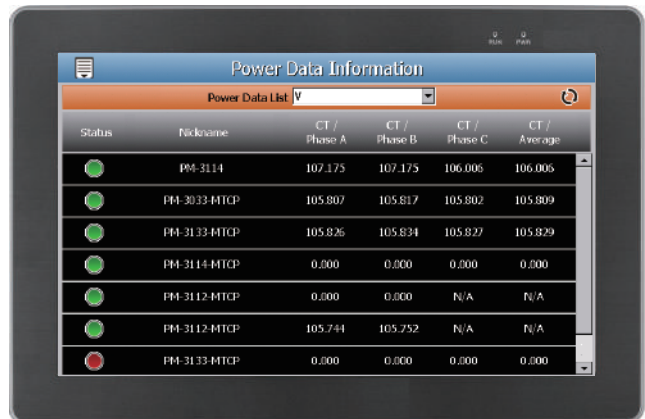
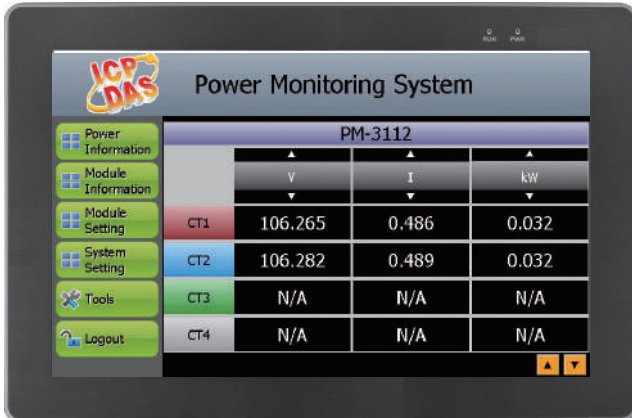

■ Built-in Intelligent logic engine for power demand management and alarm notification

PMC/PMD is equipped with IF-THEN-ELSE logic engine. The user could complete the control logic via web page and download the logic rules to the PMC/PMD. The logic engine will loop execute the rules in order. By editing the IF-THEN-ELSE logic rules, the user could use "Real time power data", "Historical Statistic power data", "power demand value", "PUE value"... etc in the IF condition setting. In addition, the Schedule setting and channel values of I/O modules connected to the PMC/PMD can be also included in the IF condition. When the evaluation of the IF condition is matched, the corresponding action will be executed (such as: alarm message sending or adjust the operation of equipment). By this way, the user could quickly implement applications for power usage monitoring, power demand management, and alarm notification sending.

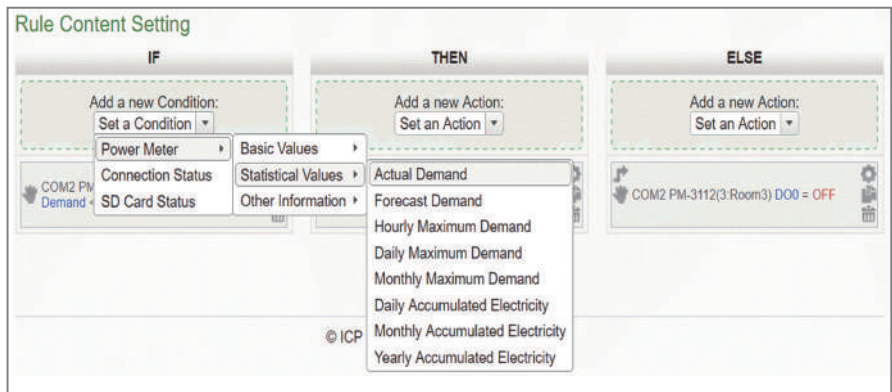

Support a variety of I/O modules to achieve the control operations of the device in real time

PMC/PMD can connect to ICP DAS M-7000 I/O modules or Modbus TCP/RTU slave modules according to the needs of the applications. With flexible and diversified I/O modules support and IF-THEN-ELSE logic rule, it enables to control the operations of devices in real time, and provides maximum flexibility for system operation and power saving.

Meter / Module Setting Page

XW-Board

None

COM2 | Modbus RTU Master

No.	Module Name / Nickname	Address	Polling Timeout(ms)
1	ICP DAS PM-3133(Room1)	1	1000
2	ICP DAS PM-3133(Room2)	2	1000
3	ICP DAS PM-3112(Room3)	3	1000
4	ICP DAS PM-3114(Room4)	4	1000
5	M-7018Z(Temp. Monitor)	5	300
6	M-7060(Power Control)	6	300

I/O Information

Options: M-7060(6:Power Control)

DI

Ch.0	Ch.1	Ch.2	Ch.3
OFF Counter: 0	OFF Counter: 0	OFF Counter: 0	OFF Counter: 0

DO

Ch.0	Ch.1	Ch.2	Ch.3
OFF	OFF	OFF	OFF

I/O Information

Options: M-7018Z(5:Temp. Monitor)

AI

Ch.0	Ch.1	Ch.2	Ch.3	Ch.4
0.000 °C	0.000 °C	0.000 °C	0.000 °C	0.000 °C
Ch.5	Ch.6	Ch.7	Ch.8	Ch.9
0.000 °C	0.000 °C	0.000 °C	0.000 °C	0.000 °C

Provide Schedule function

PMC/PMD provides Schedule function that allows to edit logic for applications that requires Schedule operation. The Calendar interface allows to easily set up the schedule for weekdays or weekends so that the user could schedule the operations for the equipments as required for efficient power usage.

Schedule Content Setting

Mode: Calendar Repeat

Date: Starting Month: 2013, November, Duration: 3 Month(s)

*Time Range(s): 08:00:00 - 17:00:00

Select All | Unselect All | Select Weekday | Select Weekend | In Range | Out of Range

2013 / 11							2013 / 12							2014 / 1						
Sun	Mon	Tue	Wed	Thu	Fri	Sat	Sun	Mon	Tue	Wed	Thu	Fri	Sat	Sun	Mon	Tue	Wed	Thu	Fri	Sat
			1	2			1	2	3	4	5	6	7	5	6	7	8	9	10	11
3	4	5	6	7	8	9	8	9	10	11	12	13	14	12	13	14	15	16	17	18
10	11	12	13	14	15	16	15	16	17	18	19	20	21	19	20	21	22	23	24	25
17	18	19	20	21	22	23	22	23	24	25	26	27	28	26	27	28	29	30	31	
24	25	26	27	28	29	30	29	30	31											

Provide instant message notification function

PMC/PMD can integrate Instant Messaging services such as Telegram, LINE and WeChat to achieve alarm message notification function. The message sending action can be added to the IF-THEN-ELSE logic edition as part of logic control to provide real-time message notification to the related personnel when an event occurs. The alarm message content could be a preset string with power data or I/O channel data. In addition, the PMC/PMD can also send the alarm notification via SMS or Email.

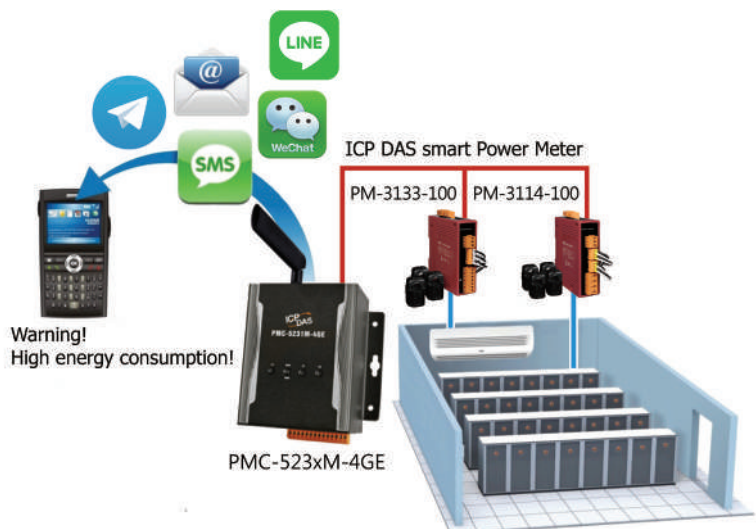

■ Support 4G/3G mobile network communication

In addition to Ethernet communication, PMC-523xM-3GWA/4GE/4GC & PMC-2x4xM(X)-4GE/4GC also supports 4G/3G mobile network communication. It can send the real-time power data, data logger files and alarm messages back to the control center by 4G/3G mobile network.

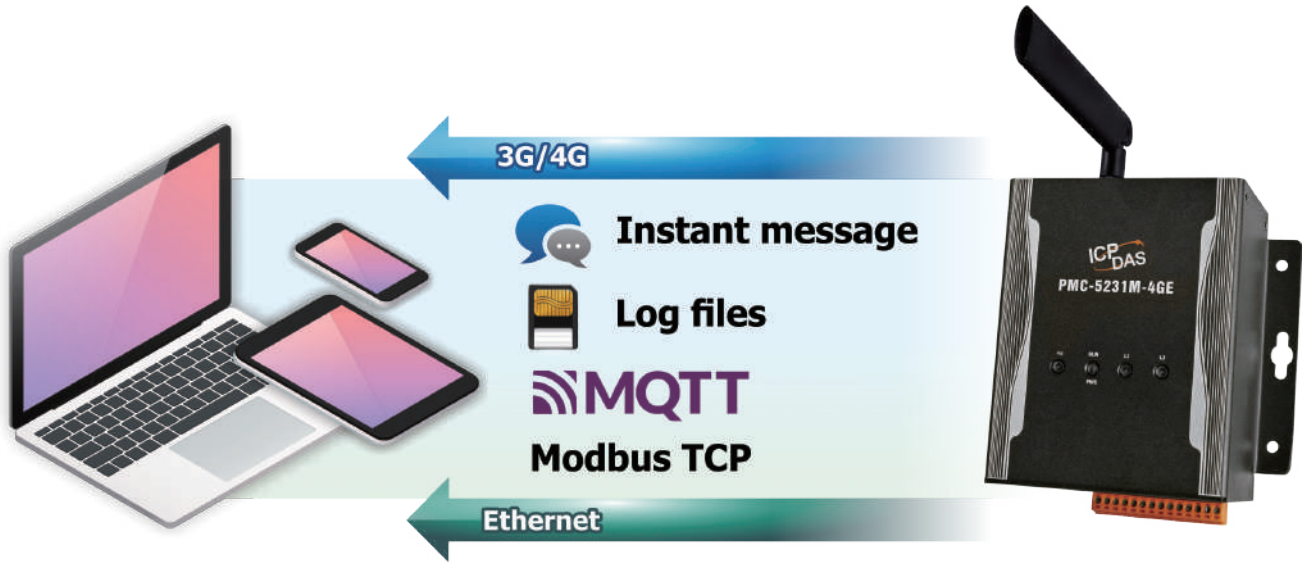

■ MQTT Message Publish/Subscribe operation for receiving power data in real-time

PMC/PMD supports the MQTT protocol. It can publish the power data of the power meters (connected to PMC/PMD) to the MQTT broker. In addition, PMC/PMD can also receive the message of the subscribe MQTT Topics published by others MQTT device and use them in the IF-THEN-ELSE logic rule to trigger the corresponding action.

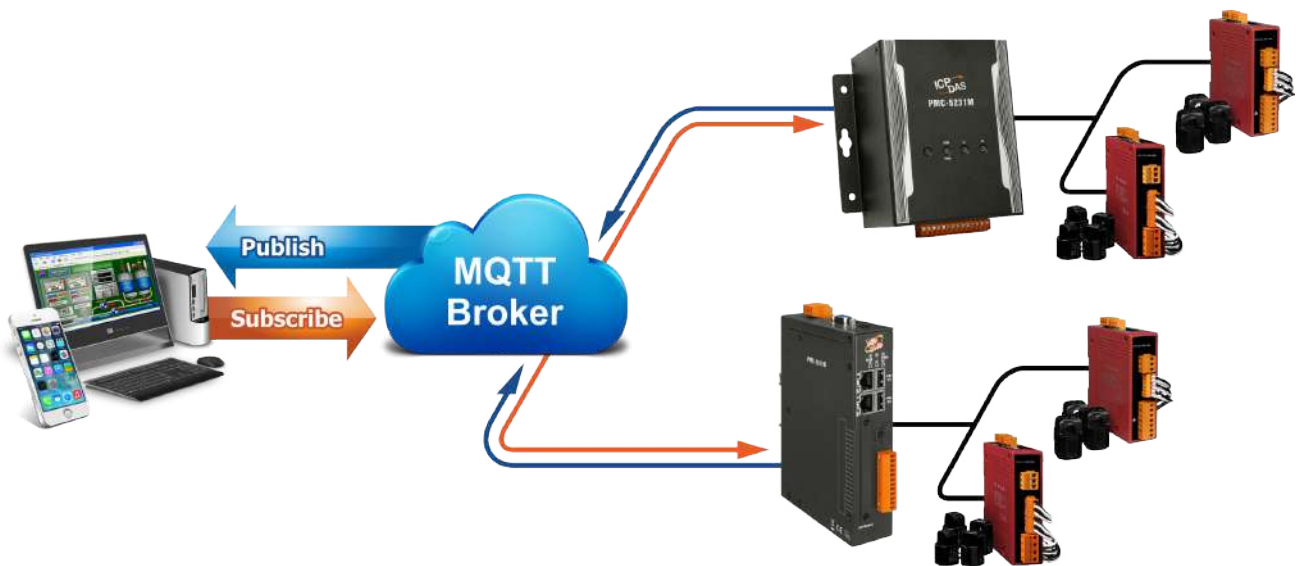

■ A variety of protocols supported, the best power meter manager for IoT power monitoring applications

PMC/PMD provides powerful and flexible integration with the power meters at the field side, and also supports various IoT protocols for seamless integration with the SCADA/MES/MIS/IT/IoT systems to transfer the power data from the front-end to the back-end management systems. It also features reliable thought-out power demand management and data logger functions. All of these features make PMC/PMD a perfect concentrator of power meters in the Energy Management application of the IoT age.

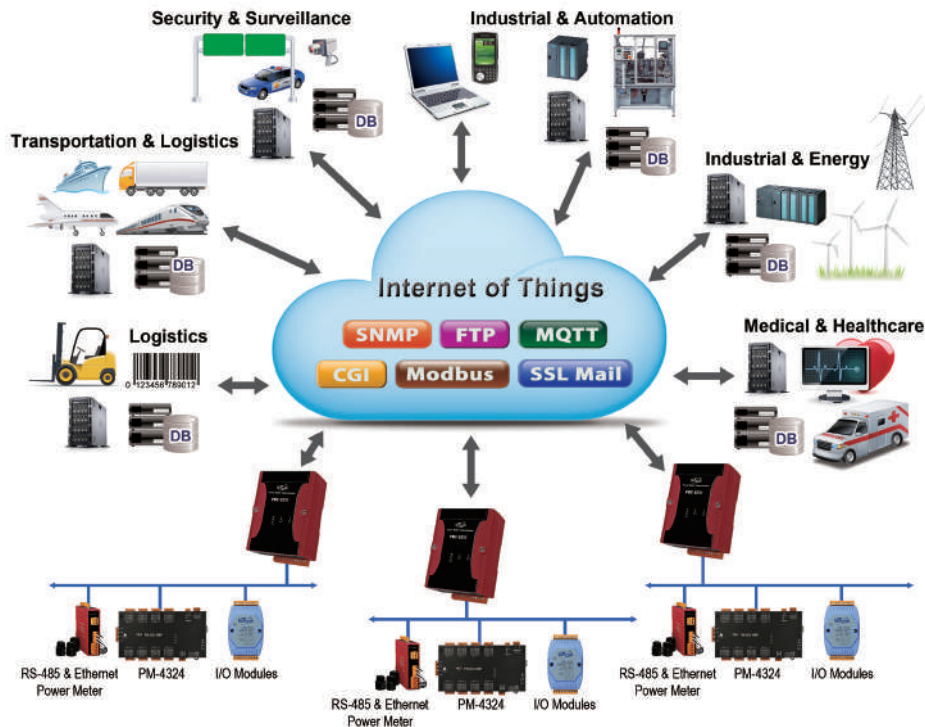

■ Power data upload operation with Security mechanism

In the era of IoT and Cloud computing, power data transmission between the power meter and Cloud platform is a prerequisite for maintaining an effective operation of the IoT Cloud system. To ensure the operations of power data uploading from PMC/PMD to Cloud platform to meet the requirements of Security mechanism, PMC/PMD supports Security mechanism such as "MQTT with SSL/TLS" to perform the encryption of real-time Sensor data during the data transmission operation. In addition, PMC-284xM also supports the Security mechanism such as VPN Client (Virtual Private Network), SNMP agent v3 (Enhanced security for SNMP protocol), SFTP(Secure File Transfer Protocol), FTPS(FTP over SSL) and HTTPS. With a variety of Security mechanism and protocols provided by PMC/PMD, it can meet the requirements of information Security when building an IoT Cloud power monitoring system.

PMC

- ✓ SSL/TLS/HTTPS
- ✓ SFTP
- ✓ SNMP agent v3
- ✓ VPN Client

■ Connection with IoT Cloud Platform and ICP DAS IoTStar

PMC/PMD supports the connection ability with the IoT Cloud Platform as Microsoft Azure, IBM Bluemix and Amazon Web Service etc. It works as the concentrator in the IoT application to connect with power meters, collect and transfer the power data to the cloud platform for future data analysis. PMC/PMD also can receive the message which is published from the cloud platform for the corresponding actions at the field side. In addition, PMC/PMD also supports connections to ICP DAS IoTStar cloud management software. IoTStar enables the Controller Remote Access Service, Power Data Collection Service, Power Data Visualization Service, Power Data Report Service and Bot Service with Mobile Phone on PMC/PMD.



■ PMC Demo Site

ICP DAS

www.icpdas.com

PMC live demo

PRODUCTS SOLUTIONS NEWS & EVENTS SUPPORT CORPORATE

PMC-5231

Character	Password
Administrator	Admin
General Users	User

PMC/PMD Specification Comparison Table

Hardware Specification

Function	PMC-284xM	PMC-224xM	PMC-523x(M)	PMD
System				
CPU	Quad-core ARM CPU, 1.6 GHz/Core	ARM CPU, 1.0 GHz		
SDRAM/Flash	DDR3 2 GB/8 GB	DDR3 512 MB/256 MB		
microSD	microSD socket with one 4 GB microSD card (support up to 32 GB microSDHC card or 2 TB microSDXC card(WISE-284xM Only))			
Ethernet	10/100/1000 Base-TX * 2		10/100/1000 Base-TX * 1	
TFT LCD(with Touch Panel)	N/A			PMD-220x: 7" TFT LCD PMD-420x: 10" TFT LCD
Wireless Communication (Applied to 3G/4G version PMC-523xM, PMC-224xM & PMC-284xM)				
3G/4G System (-4GE)	FDD LTE: B1/B3/B5/B7/B8/B20 bands (Frequency Band for EMEA, Korea, Thailand, India and Taiwan) WCDMA: 850/900/2100 MHz			
3G/4G System (-4GC)	FDD LTE: B1/B3/B8 bands (Frequency Band for China) TDD LTE: B38/B39/B40/B41 bands (Frequency Band for China) WCDMA: 900/2100 MHz, TD-SCDMA 1900/2100 MHz, CDMA2000 (BC0) 800 MHz			

Software Specification

Function	PMC-284xM/PMC-224xM/PMC-523x(M)	PMD
Operation Interface	Web Page	Web Page & Touch Screen
Power Data Collection	<ul style="list-style-type: none"> Power data collection, real-time and historical power data displayed Power data logging and historical power data statistics report provided PUE information provided and displayed 	
Power Demand Management	<ul style="list-style-type: none"> Built-in IF-THEN-ELSE logic engine for thought-out power demand management Adjust equipment operation by its power usage status via Modbus I/O modules Provide Schedule function to manage the equipment's operation(work with Modbus I/O modules) Provide message notification function via Email, Telegram and LINE (3G/4G version provides SMS message notification function; PMC-xxx6/PMD-x206 provides WeChat message notification function; PMC-284x provides WeChat message notification function) 	
Integration with SCADA/IT/IoT/Cloud Systems	<ul style="list-style-type: none"> Support Modbus TCP/RTU, MQTT, SNMP and CGI protocols to transmit real-time power data Power data log file auto send-back (by FTP protocol) & recovery when network is resumed after disconnection Support DDNS (Dynamic DNS) system Support Microsoft Azure, IBM Bluemix and Amazon Web Service (WISE-284xM Only) IoT Cloud platforms Support ICP DAS IoTstar Cloud software 	
Information Security Mechanism (PMC-284xM Only)	<ul style="list-style-type: none"> Support HTTPS encryption protocol for Web interface operation Support VPN Client function (PPTP, L2TP, OpenVPN and SoftEther protocols) Support SNMP v3 encryption protocol to ensure the security of the connection with IT system Support SFTP & FTPS mechanisms to ensure that file transfers are encrypted through TLS Support Blacklist and Whitelist setting to filter and exclude the accessible domains 	

1.4 Cloud Management Software - IoTstar 2025

Introduction

IoTstar 2025 is the latest version of ICP DAS's IoT cloud management software. It integrates the original IoTstar software and service packages (Dashboard Service, Report Service, Bot Service, etc.) into a single product, streamlining IoTstar's purchasing and installation process while making the system more intuitive and convenient to use. In addition to retaining all features and service packages from the previous version, IoTstar 2025 introduces several new user-centric functions and significantly enhances the overall user experience.

IoTstar 2025 can be installed on private PCs or VM (Virtual Machine) systems hosted on cloud platforms such as Microsoft Azure, IBM Bluemix, Amazon AWS and Google Cloud. This enables users to quickly establish their own IoT cloud monitoring systems. With IoTstar 2025, users can create IoT cloud systems that deliver the following services:



During the development of an IoT cloud system, no programming is required, system configuration can be completed through a web interface. Additionally, with SQL commands, IoTstar 2025 seamlessly integrates with cloud platforms and data analysis tools (such as Power BI, Google Looker Studio, or Grafana), enabling users to efficiently build “IoT + Big Data” cloud applications. This significantly reduces both the time and cost associated with implementing “IoT + Big Data” cloud solutions.

System Architecture

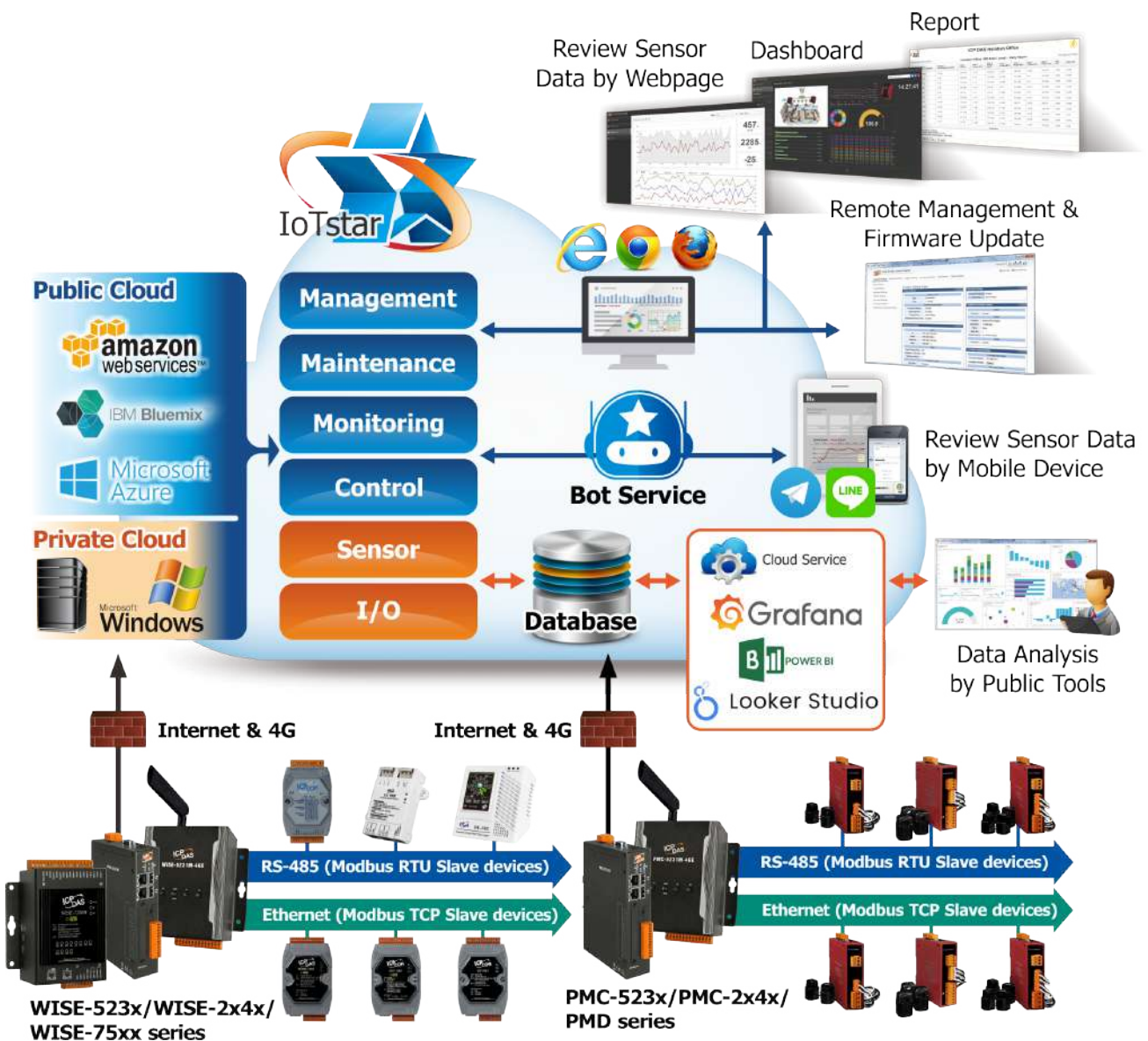

Features

Support Flexible Installation Environment for Quick IoT Cloud System Setup

The installation environment can be flexibly chosen based on site requirements.

● **Public IoT Cloud Solution:**

IoTstar 2025 can be installed on VMs(virtual machine) within public cloud platforms such as Microsoft Azure, IBM Bluemix, Google Cloud, or Amazon AWS. This setup supports WISE, PMC, and PMD controllers while reducing the burden of maintaining the IoT cloud infrastructure.



● **Private IoT Cloud Solution:**

If users are concerned about system operation or data storage environments, IoTstar 2025 can be installed on a private Windows PC (Windows 7/8/10 or Windows Server) to implement a private IoT cloud solution for WISE, PMC, and PMD controllers. This allows users to manage and control their own IoT cloud environment, ensuring complete oversight of operations.

No programming required! Set up the IoT Cloud system with a browser.

Setting up the IoT cloud system is as simple as a few clicks on the IoTstar and WISE/PMC/ PMD controller web interfaces. With no need for coding, users can quickly configure the system through a browser and have it running in no time.

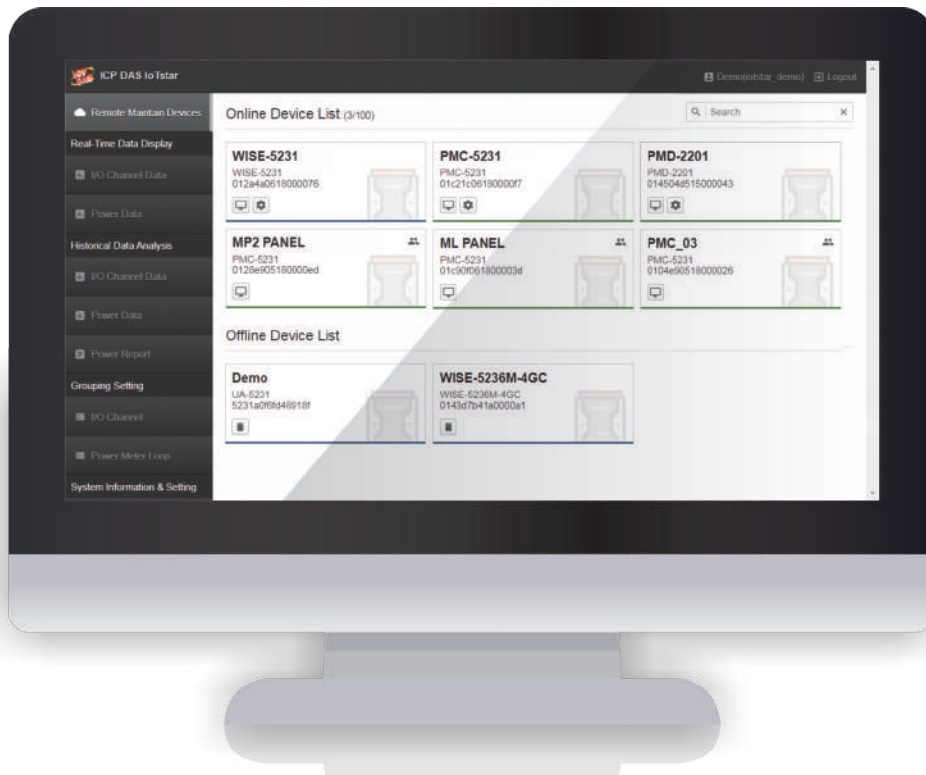

Controller Remote Access Service

With IoTstar 2025, users no longer need to worry about the network environment of WISE, PMC, or PMD controllers—whether they use static, dynamic, virtual, or physical IP addresses. Through the web interface provided by IoTstar 2025, users can remotely monitor status, adjust system settings, and update firmware, minimizing the time and cost required for personnel to travel for on-site maintenance operations.

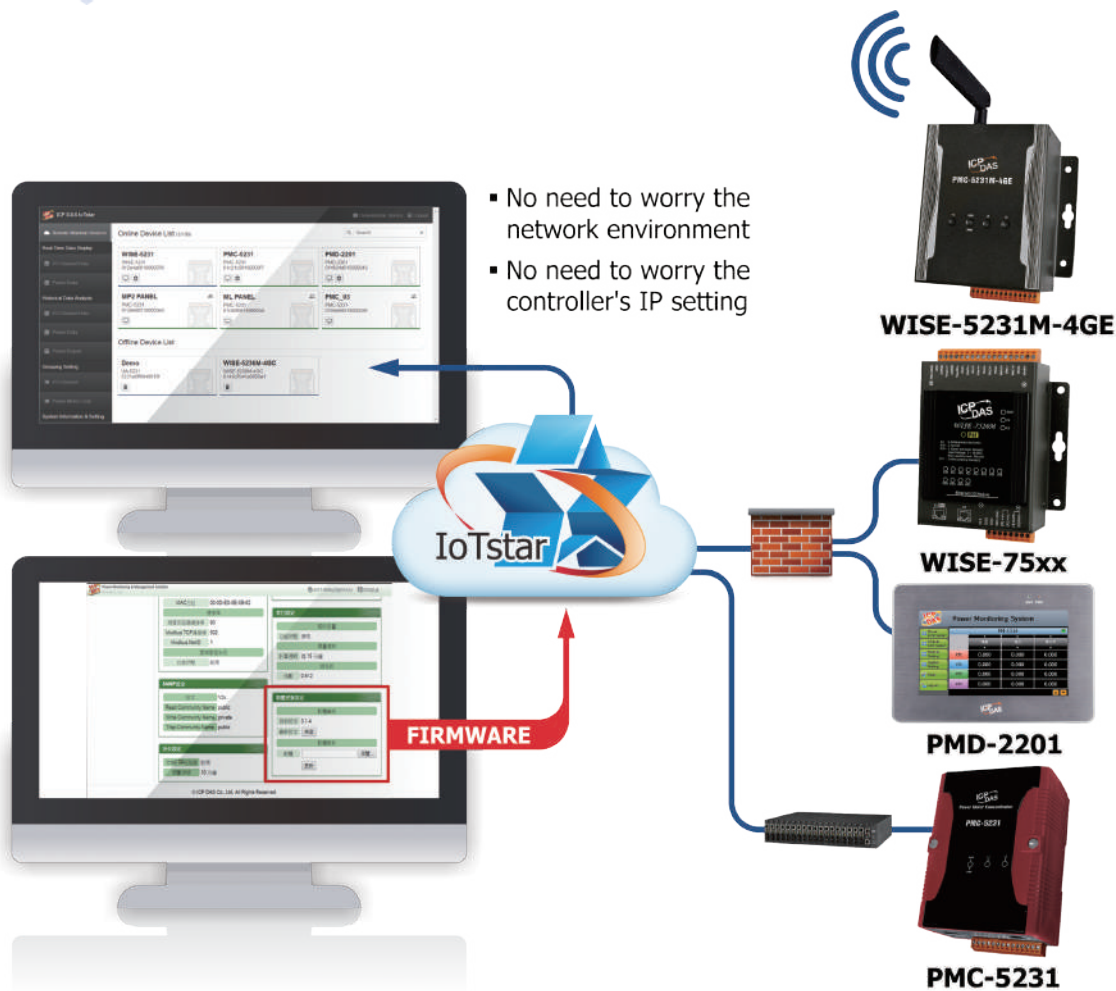
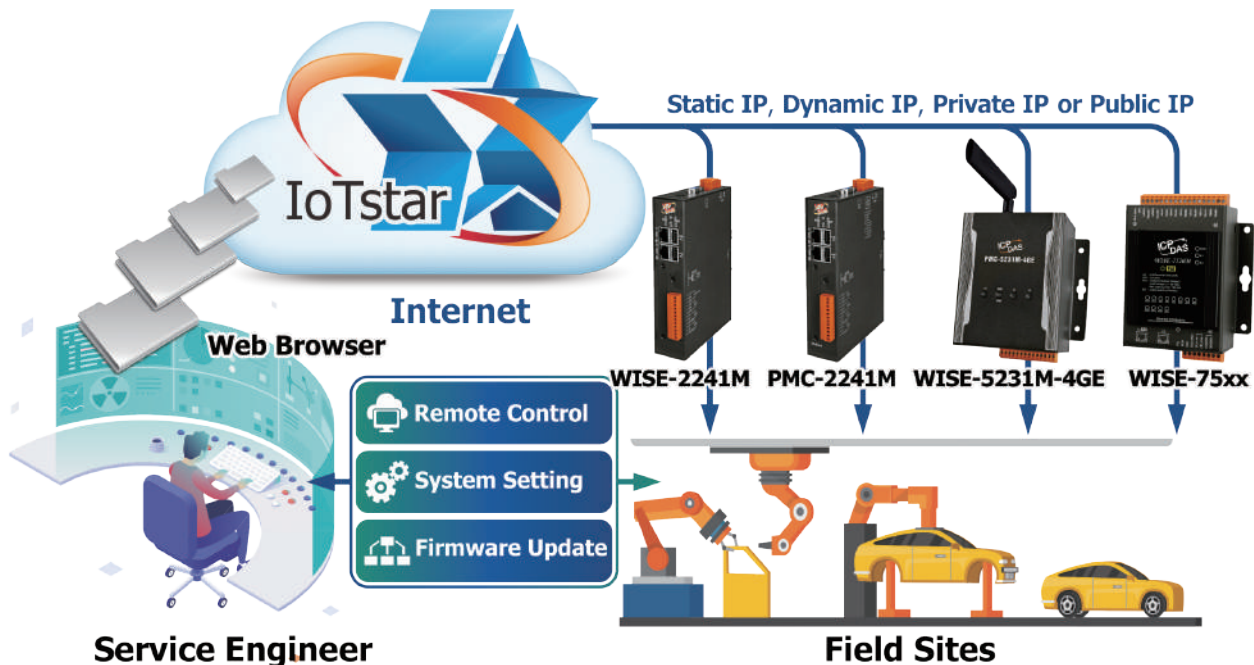

■ Sensor Data Collection Service

With IoTstar 2025, sensor data collection can efficiently gather both historical and real-time data from sensors or power meters connected to WISE, PMC, or PMD controllers. This data is imported into a cloud database, quickly establishing a data lake for "IoT and Big Data" applications. Users can also modify the database data via SQL commands to control the DO/AO channels of sensors connected to the controllers.



The SQL command interface makes it easy to integrate the sensor data stored by IoTstar 2025 with third-party data analysis tools (such as Power BI, Looker Studio, and Grafana) as well as ERP/MES systems. This seamless integration of OT (Operational Technology) and IT (Information Technology) systems enables comprehensive, real-time insights into system operations, supporting better decision-making and operational efficiency.

Sensor Data Recovery Mechanism

In typical cloud data collection processes, sensor data is gathered and sent to the cloud for storage in a database. However, if a network disconnection occurs, any data transmitted during that period may be lost. IoTstar 2025 addresses this issue with a built-in sensor data recovery mechanism. During a network disruption, WISE, PMC, or PMD controllers temporarily store all data on their SD cards. Once the network connection is restored, the stored data is automatically retransmitted to IoTstar 2025 and imported into the database, ensuring the completeness and integrity of historical sensor data.

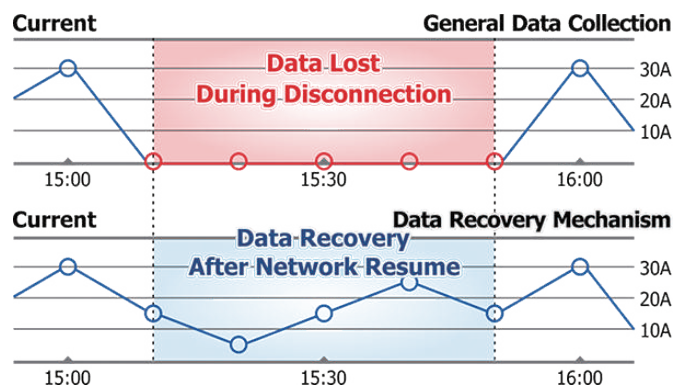

■ Sensor Data Visualization Service

IoTstar 2025 provides real-time and historical data queries for sensors and power meters connected to remote WISE/PMC/PMD controllers. It features dedicated power analysis pages that help users query and compare power consumption across different time periods, analyze usage trends, and identify potential energy-saving opportunities. At the same time, it helps reduce carbon footprints and contributes to environmental sustainability.

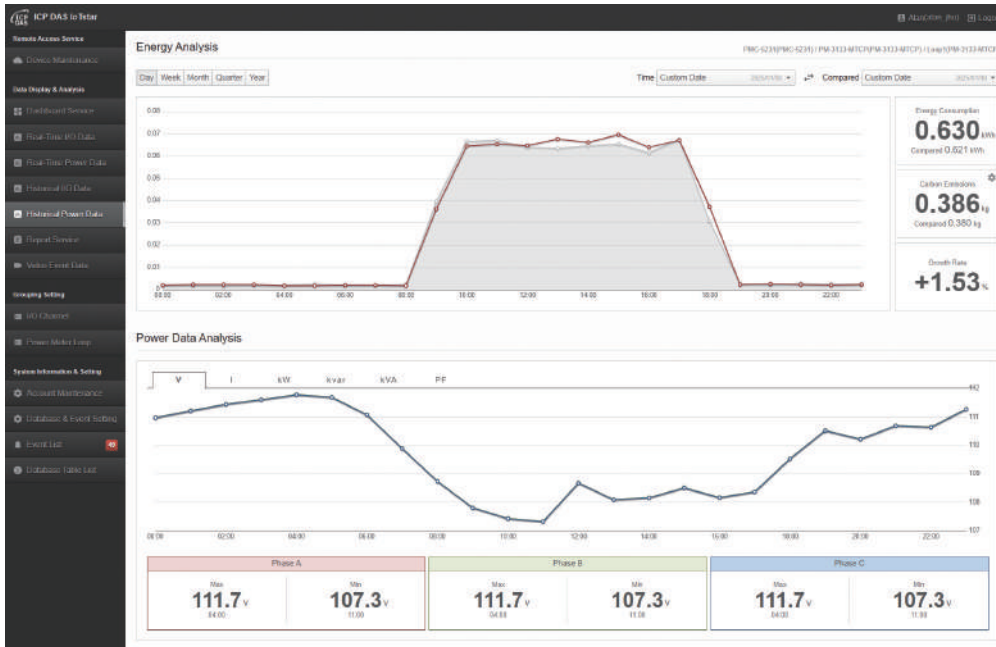

IoTstar 2025 offers a dashboard editor and various widget components, enabling users to create customized dashboards for viewing real-time data from sensors or power meters connected to WISE, PMC, or PMD controllers. Users can quickly build the dashboards needed for IoT cloud monitoring, monitor sensor or power meter status in real-time, and interact with them directly.



■ Sensor Data Report Service

IoTstar 2025 offers a powerful statistical report generation feature, enabling users to create reports from data collected by sensors or power meters connected to WISE, PMC, or PMD controllers. This feature transforms raw data into meaningful reports, providing insights into the operational status of machines, equipment, and facilities. These reports serve as an essential basis for informed decision-making, helping to eliminate bias and avoid blind spots.

Power meter loop report PMC-5231(Xindian office) / PM-4324-MTCP(Power meter of Area A) / Loop1(wall socket 1)

Time	Max. Demand(kW)	Energy Consumption(kWh)	Avg. PF(%)	Avg. I Phase A(A)	Avg. V Phase A(V)	Avg. I Phase B(A)	Avg. V Phase B(V)	Avg. I Phase C(A)	Avg. V Phase C(V)	Avg. kVA	Avg. kvar
0	0.05	0.05	89.713	0.169	110.354	0.169	110.35	0.17	110.358	0.055	0.024
1	0.05	0.05	89.566	0.169	110.557	0.168	110.553	0.169	110.562	0.056	0.025
2	0.05	0.05	89.562	0.169	110.776	0.169	110.771	0.17	110.78	0.056	0.025
3	0.05	0.05	89.628	0.17	110.975	0.17	110.972	0.17	110.982	0.056	0.025
4	0.051	0.05	89.375	0.17	111.112	0.169	111.108	0.17	111.118	0.056	0.025

Summary

Daily Highest Usage: 0.051kW
 Occurrence Time: 2021-10-19 04:59:00
 Daily Total Electricity Consumption: 0.41kWh

■ Bot Service on Controller by using Mobile Device

IoTstar 2025 offers a built-in chat room feature that allows users to interact with WISE, PMC, or PMD controllers via the LINE or Telegram app, providing a fast and convenient way to manage equipment. Unlike traditional chatbots that rely solely on text commands, it features a user-friendly interface with buttons and dialog menus for easy access to information.

With this functionality, users can query real-time data from on-site I/O modules or power meters and adjust DO/AO channel values anytime, anywhere. Additionally, IoTstar 2025 can receive alarm events proactively sent by WISE, PMC, or PMD controllers and forward them to relevant LINE or Telegram users for real-time notifications. All alarm events are logged within IoTstar 2025, allowing users to review historical events using its event query feature.

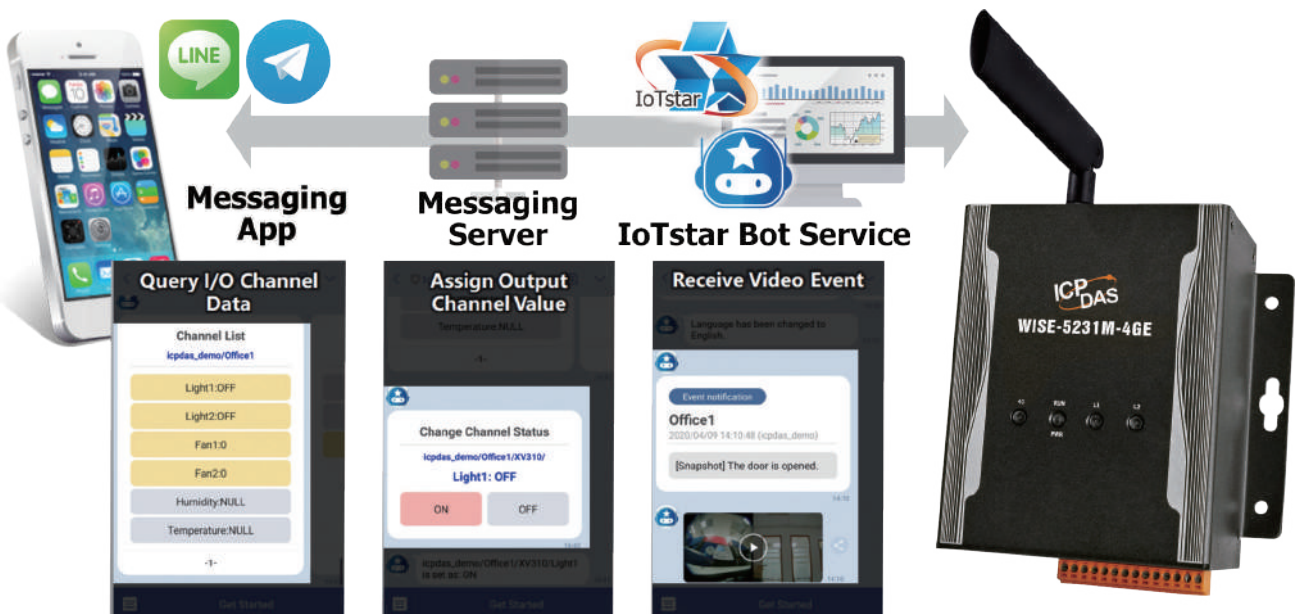

Application

Cloud-based Power Monitoring Application for Factory

Using ICP DAS "IoTstar + PMC/PMD" solution, user can quickly build a cloud-based power monitoring system for factory. In the solution, PMC/PMD power meter concentrator can connect with ICP DAS power meters to collect, organize and record the power consumption information of the factory equipment. In addition to sending the collected power information back to IoTstar, PMC/PMD can also perform the power demand management for the equipment, monitor the operation of equipment to perform the corresponding actions, and immediately send LINE/Telegram/WeChat/Email/SMS alarm message according to the pre-set edge computing mechanism (IF-THEN-ELSE logic rules). After IoTstar receives the power information sent by PMC/PMD, it can provide services such as: "Controller Remote Access Service", "Sensor Data Collection Service", "Sensor Data Visualization Service", "Sensor Data Report Service" and "Bot Service with Mobile Phone", as well as the following benefits:

- No need to write programs in the whole process, power information can be collected and stored in the cloud database automatically.
- Through SQL Database interface, quickly integrate the IT system to understand the trend and change of the power usage status of the factory equipment comprehensively.
- Perform remote monitoring and maintenance of the factory equipment, take corresponding actions proactively to ensure operational optimization.
- Provide status monitoring, system setting and firmware update for the PMC/PMD controllers from Cloud. It can reduce the time and cost of personnel travel due to performing maintenance of the equipment.

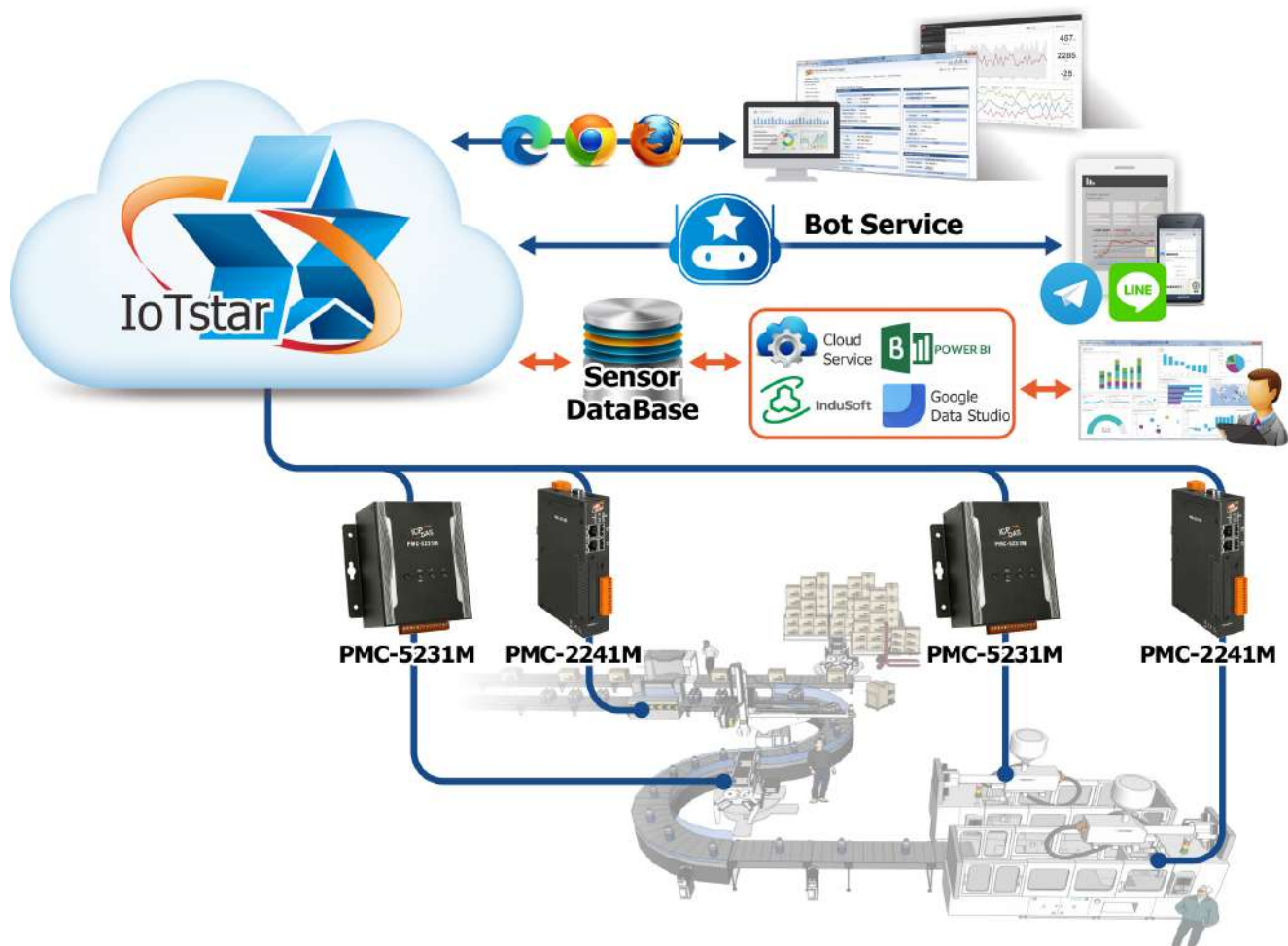

IoTstar 2025 Live Demo (iotstar.icpdas.com)

The IoTstar 2025 Live Demo enables users to explore its full range of features, including:

- Cloud-based monitoring and configuration of onsite WISE, PMC, and PMD controllers.
- Access to data from sensors or power meters connected to the controllers.
- Interactive data visualization dashboards for sensor or power meter data.
- Generation of statistical reports for sensor or power meter data.
- Viewing image events captured by iCAM series network cameras integrated with WISE controllers.

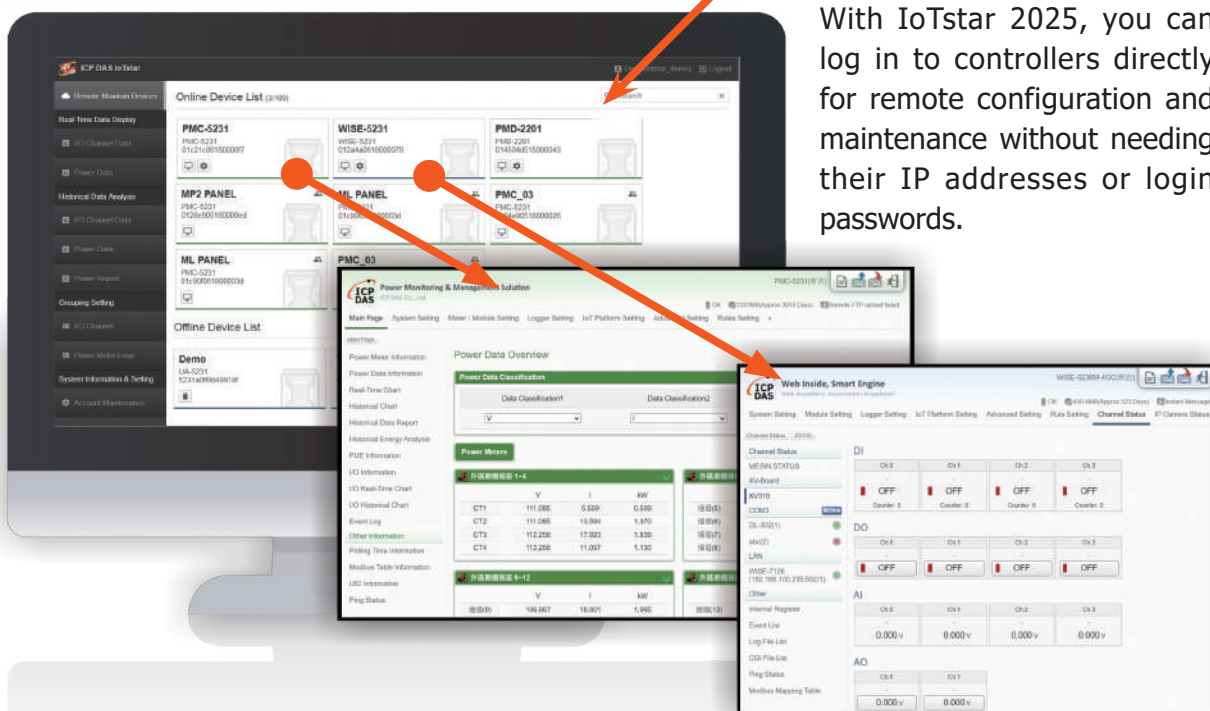

Controller Supported List

Model	WISE-284xM	WISE-224xM	WISE-523x(M)	WISE-75xxM
System				
CPU	Quad-core ARM CPU, 1.6 GHz/Core	ARM CPU, 1.0 GHz		32 bits CPU (400MHz)
microSD	Yes (Built-in one 4 GB microSD card)			-
Ethernet	10/100/1000 Base-TX * 2		10/100/1000 Base-TX * 1	10/100 Base-TX * 2 (for Daisy-Chain Topology)
Casing	Metal(WISE-523x is Plastic)			Metal
Mobile Network	Support 3G/4G Mobile Network(*1)			-
I/O Module Support				
Local Side	Support ICP DAS XV-board			Built-in I/O module
Remote Side	Support at most 48 I/O modules			-
iCAM IP Camera	up to 12	up to 4		-
Software function				
Intelligent logic operation	Yes (Full Function)			Yes (Basic function)
Information Security Enhancement	Yes	-		-

Model	PMC-284xM	PMC-224xM	PMC-523x(M)	PMD
System				
CPU	Quad-core ARM CPU, 1.6 GHz/Core	ARM CPU, 1.0 GHz		
microSD	Yes (Built-in one 4 GB microSD card)			
Ethernet	10/100/1000 Base-TX * 2		10/100/1000 Base-TX * 1	
TFT LCD (with Touch Panel)	-			PMD-220x: 7" Display PMD-420x: 10" Display
Casing	Metal (PMC-523x is Plastic)			Metal
Mobile Network	Support 3G/4G Mobile Network (*1)			-
Power Meter & I/O Module Support				
Local Side	Supports ICP DAS XV-board (PMC-2241M-iWSN not supported)			-
Remote Side	Support at most 48 modules (Include ICP DAS Modbus Power Meters and Modbus I/O modules)	Support at most "24 ICP DAS Modbus Power Meter + 8 Modbus I/O modules" (PMC-2241M-iWSN supports up to 93 ICP DAS iWSN wireless modules)		
Software function				
Intelligent logic operation	Yes (Full Function)			
Information Security Enhancement	Yes	-		-

Note 1:

3G/4G version of WISE-523xM, WISE-224xM, WISE-284xM, PMC-523xM, PMC-224xM & PMC-284xM

3G system (-3GWA)	WCDMA: 850/900/1900/2100 MHz
3G/4G system (-4GE)	FDD LTE: B1/B3/B5/B7/B8/B20 bands (Frequency Band for EMEA, Korea, Thailand, India and Taiwan) WCDMA: 850/900/2100 MHz
3G/4G system (-4GC)	FDD LTE: B1/B3/B8 bands (Frequency Band for China) TDD LTE: B38/B39/B40/B41 bands (Frequency Band for China) WCDMA: 900/2100 MHz, TD-SCDMA 1900/2100 MHz, CDMA2000 (BC0) 800 MHz

Ch2. Applications

The energy management solutions launched by ICP DAS include: power meter, PMC/PMD power meter concentrator, back-end management software (such as: IoTstar cloud management software, InduSoft SCADA software). It provides functions such as "Power information query and display", "Power data statistical report provide", "Power demand management", "Instant message notification", etc. It can assist enterprises to quickly and effectively achieve the goal of energy saving and carbon reduction under the general trend of "ESG", and also the best power monitoring solution under the ESG sustainable development goals of enterprises.



Power monitoring for factory

The power monitoring solution developed by ICP DAS (PMC/PMD, power meter) for factory power monitoring systems can be used to control the power demand status in real time, and when the power demand is predicted to be going to exceed the contracted capacity, an alarm message will be issued to notify the user to make adjustment of equipment operations to avoid penalties for exceeding contract capacity. In addition, PMC/PMD can provide back-end platform the power usage information to analyze the power consumption information, assist factory to design optimal power usage plans, and reduce the electricity cost.

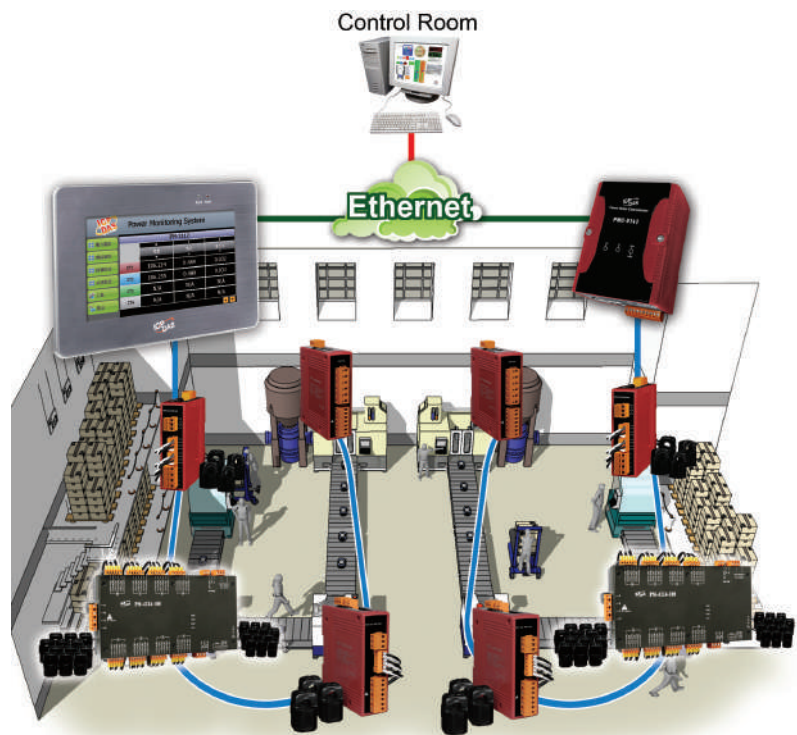

Power and environment monitoring for factory

Using the power and environmental monitoring solutions(air detector modules, power meters, PMC/PMD power meter concentrators) developed by ICP DAS, the data of power, temperature, humidity and air particles of factories and production lines can be collected and recorded in real time and send back to the back-end management center to assist enterprises to collect and analyze the power and environmental monitoring data of the factories, and then achieve the purpose of energy saving and environmental protection.



Equipment predictive maintenance

Using the power monitoring solution(power meter, PMC/PMD meter concentrator) developed by ICP DAS, the power usage status of equipment can be monitored in real time, and when the predicted power demand is going to exceed the contracted capacity, an alarm message can be issued to notify the user, and the operation of the equipment can be adjusted in real time. In addition, it also provides power usage information of the equipment to the back-end management platform for statistics and analysis. In addition to reduce electricity costs for factory, it also provide a predictive maintenance operation for equipment to ensure the proper operations of factory and production lines.

Case 1: Real-time monitoring of the current data of the inverter in the predictive maintenance

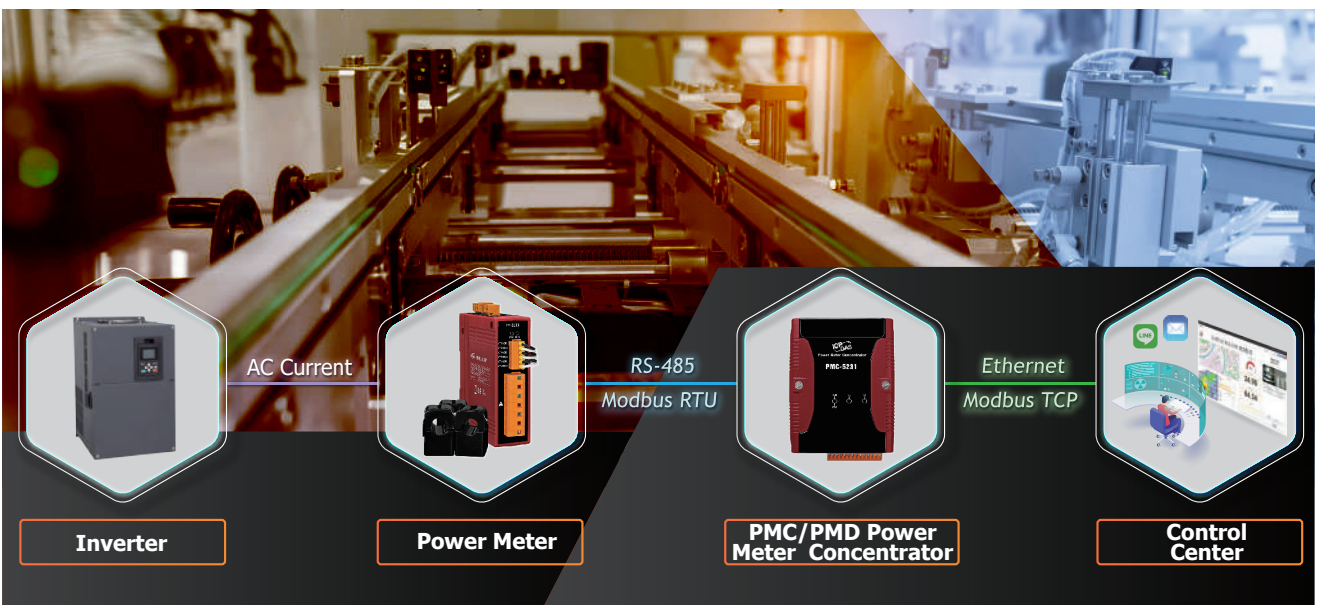

Case 2: Real-time monitoring of the voltage/current data of the Oil expeller in the predictive maintenance.



Power monitoring for building, community and residence

The power monitoring solution developed by ICP DAS can be used in buildings, communities, and residences. The user can install PMC/PMD in the application and connect with ICP DAS smart meters to collect and record the power usage data of air conditioner, light, drainage and other equipment. And the power data log files will be sent back automatically to the back-end office for statistics and analysis of the power consumption information to adjust the power demand policy, avoid improper power consumption behaviors and ensure stable power supply quality in the application field and save the electricity costs.

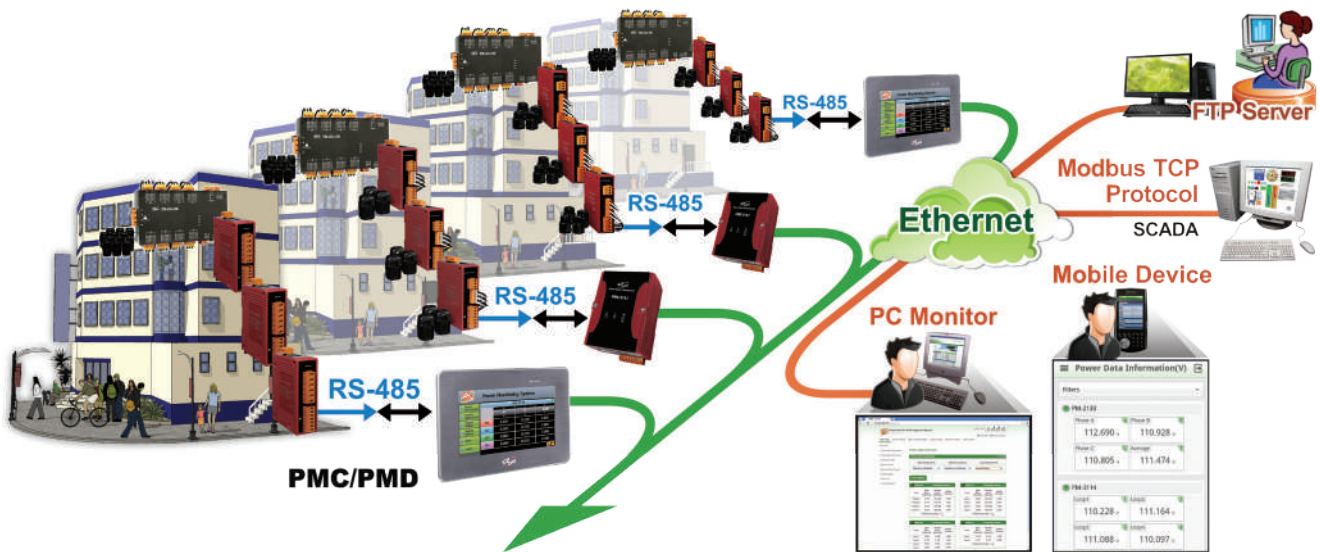

Power monitoring for public place

ICP DAS provides a power monitoring solution for public place. The user can install PMC/PMD in the application and connect with ICP DAS power meters to collect and record the power usage data for air conditioner, light, drainage and other equipment. In addition, user can also set up the alarm notification according to the contract they signed. When the power consumption is going to exceed the contract capacity, the PMC/PMD will send instant notifications message to related personnel for immediate actions to avoid penalties for exceeding contract capacity. And through the statistics and analysis of the electricity usage information of each equipment, it is possible to establish a long-term and effective electricity management system to achieve the purpose of saving electricity costs and carbon reduction.

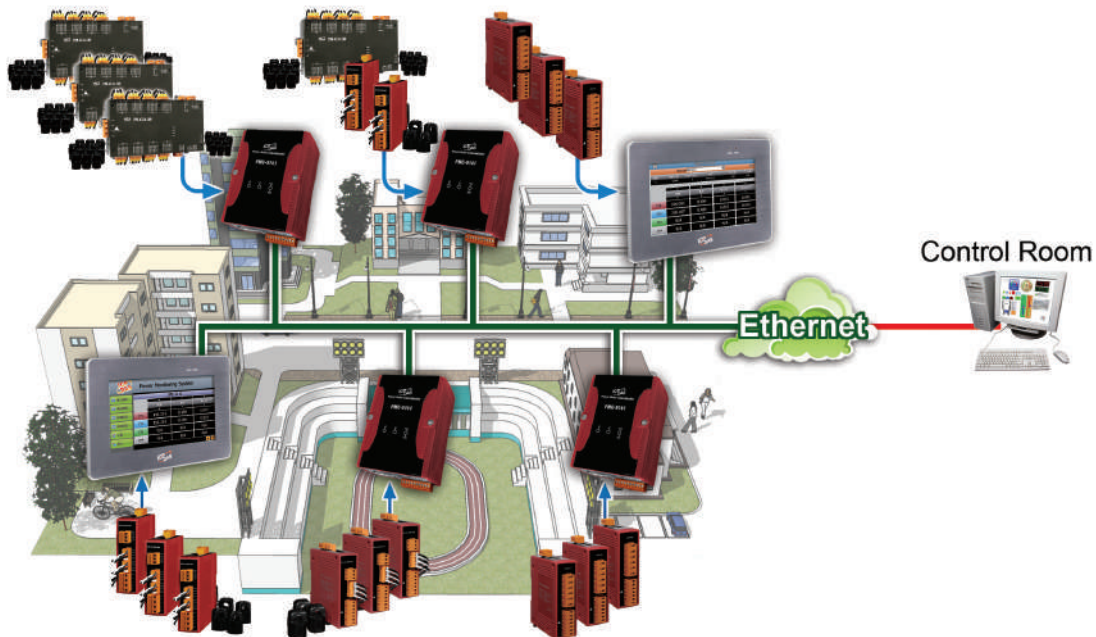

Electricity Consumption of Machines

In order to ensure the stability and reliability of the machines; usually it requires the monitoring of electricity consumption. The purpose is not only for energy saving, but also to investigate the influence of electric current variation that may affect the yield rate of the products during the production process. For most machines uses both AC and DC power supply, if the traditional power meters are used, it may require several power meters to implement the monitoring jobs. By using M-7017RMS, it can monitor multiple circuits at the same time and support both AC and DC current monitoring; so that it will save the installation space and no need to install lots modules for individual functions.

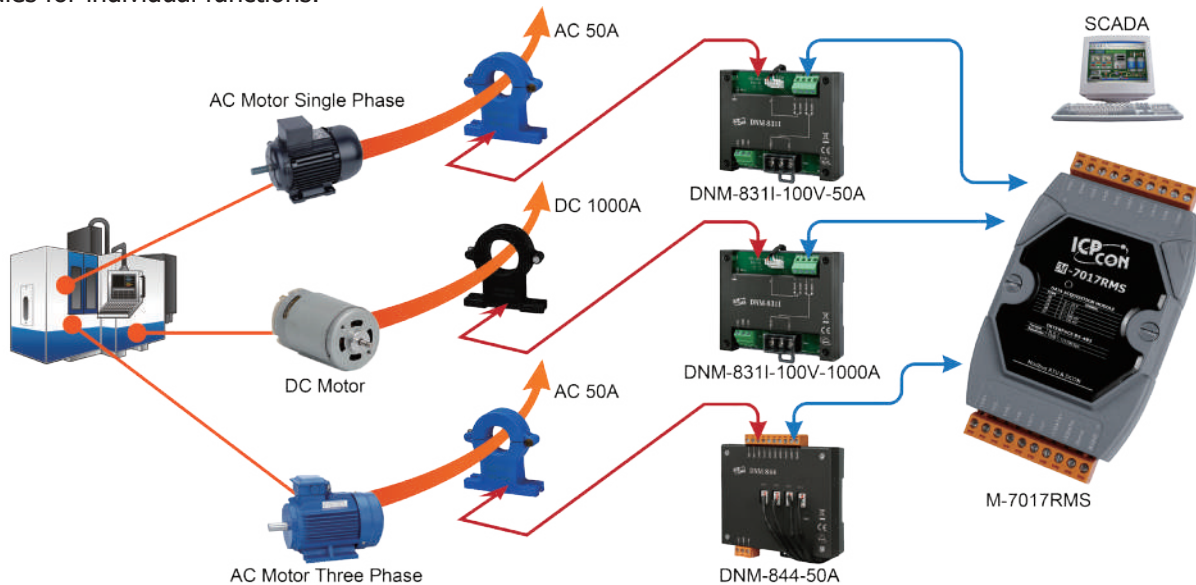

Ch3. SCADA System Software: InduSoft



InduSoft Web Studio is a powerful, integrated collection of automation tools that includes all the building blocks needed to develop modern Human Machine Interfaces (HMI), **Supervisory Control and Data Acquisition (SCADA)** systems, and embedded instrumentation and control applications. InduSoft Web Studio supports all Windows runtime platforms, ranging from Windows CE, Windows 7 (32/64 bit), Windows 8 (32/64 bit), Windows 10, and Windows Server Editions, along with built-in support for local or remote (web) based visualization. InduSoft also conforms to industry standards such as Microsoft .NET, OPC, DDE, ODBC, XML, and ActiveX.

ICP DAS provides the InduSoft bundled driver to integrate InduSoft software and ICP DAS products (I-7000, I-8000, I-87K and CAN Series) for SCADA system. Besides, the VxComm software of ICP DAS can be performed to link to Internet/Intranet modules in an easy way. And DCON Utility of ICP DAS can be used to configure network module for easy use and maintenance.

InduSoft Features

Streamlined Licensing

Now all license levels support an unlimited number of concurrent communication drivers (limited only by hardware constraints). Native communication drivers for the electrical protocols (DNP3/IEC) available for Full Runtime and EmbeddedView, are no longer an add-on. License no longer restricts the type of Thin Clients, nor pre-defined packages of Thin Clients. The user can define the exact maximum number of Thin Clients that should be concurrently supported by the license.



OPC UA Server

Support is now included for the OPC UA Server for full runtime, EmbeddedView, and IoTView.

Drivers and OPC

IWS 8.1 not only Provides over 250 native communication drivers but also native OPC interfaces, such as OPC UA (Client/Server), OPC DA (Client/Server), OPC XML (Client), OPC .NET (Client), and OPC HDA (Server), and many other devices.

Graphics and Design Tools

Create screens to meet any application requirement using the tools in our graphic interface. Combine over 1,000 animated objects to create any functionality required. Store graphics in the library for future use, and easily make projects across a product line share a consistent "look and feel".

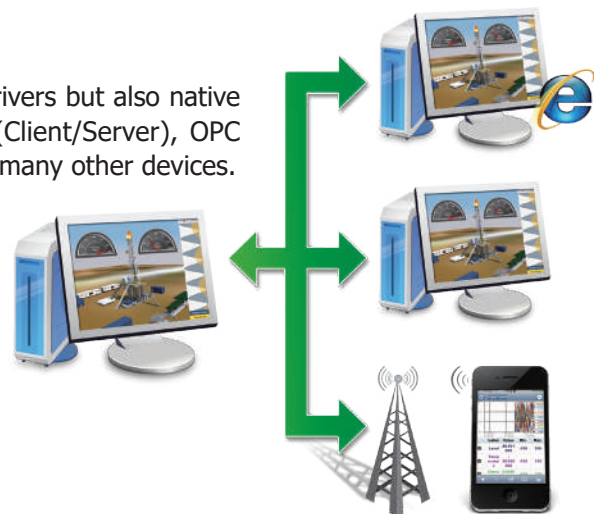

Alarms

Send online alarms or reports using multi-media formats like PDF. Alarms are real-time and historical; log data in binary format or to any database. Use remote notification to send alarms right to your inbox, printer, or smartphone. Custom Alarm fields allow you to customize up to 10 additional fields to the alarm history.

Animation

Take command over graphics in a user friendly and intuitive interface. Paste images, and even rotate dynamically using custom rotation points. Fill bar graphs with color, or adjust the scale of objects with easy-to-use configuration. Other animations include 'command' (for touch, keyboard and mouse interaction), hyperlink, text data link, color, resize, transparency, and position.

Multi-Language

Develop your application in one of many development languages, including English, Portuguese, German, French, Russian, Chinese Traditional and Simplified, and Spanish, or use translation tools to switch the runtime to any language. InduSoft Web Studio offers automatic font replacement based on the language selected.

Database

Connect to SQL database (Microsoft SQL, MySQL, Sybase, Oracle), or Microsoft Access or Excel, and ERP/MES systems (including SAP), even from Windows Embedded Compact Edition. The flexible built in interface doesn't require knowledge of SQL. A patented solution allows for communication with SQL and relational databases running on any supported platform.

Recipes and Reports

Save time and maintain consistency by automating part parameters or production quantities with flexible recipe management tools. Create clear, concise reports in plain text, RTF, XML, PDF, HTML, and CSV or integrate with Microsoft Office programs such as Excel. Get the data you need, in the format you need it, to make informed decisions, fast.

Scheduler

Schedule application behavior triggered by tag changes, date/time, frequency, or any trigger. Use this for simulation, to trigger reports or other functionality at a particular time of day, or even to trigger driver worksheets to read/write at a scan rate you choose.

Trends

Real-time and Historical trends, and SPC functionality are supported. Log data in binary format, or to any local or remote SQL database. Color or fill trends with graphic elements to enhance clarity of data. Date/Time based or numeric (X/Y plot) trends give you the flexibility to display information that best suits your application. InduSoft Web Studio supports vertical and horizontal trending.

Scripting

Two powerful scripting languages are supported; built-in InduSoft functions and standard VBScript. Take advantage of widely available resources for VBScript. Both the native InduSoft scripting language and VBScript can be used simultaneously to give you the functionality you need, even from thin clients. Script debugging tools for the native VBScript editor include break-points, and a variable watch list to improve scripting productivity.

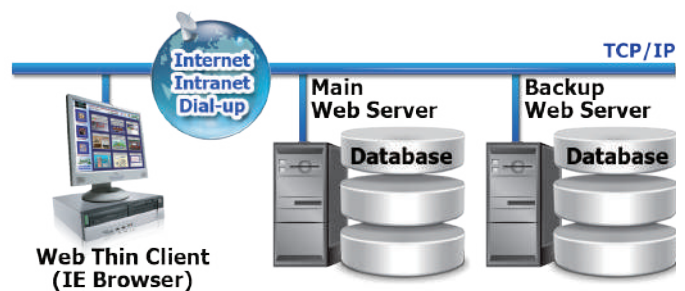
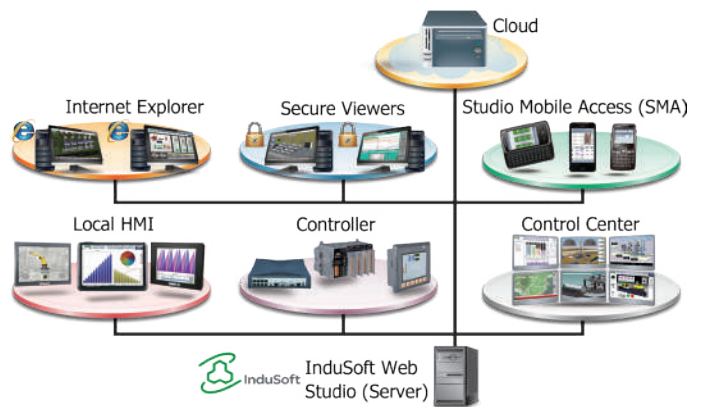

InduSoft Software Ordering Information

IWS Development Package for Windows	InduSoft development package can generate applications for Windows, Windows Embedded and Windows Embedded CE
IWS Runtime Package for Windows	InduSoft runtime package for Windows, Windows Embedded
IWS Runtime Package for Windows Embedded CE	InduSoft runtime package for Windows Embedded CE
Additional Package for Development or Runtime License	The additional package number of Thin Clients

Ch4. PMC/PMD Power Meter Concentrator

4.1 Advanced IIoT Power Meter Concentrator



Features

- No extra software tool is required, using browsers to perform system operations
- Support at most 48 modules (Include ICP DAS Modbus Power Meters and Modbus I/O modules)
 - * COM3 and COM4 can connect to Max. 16 Modbus RTU modules individually.
 - * LAN can connect to Max. 16 Modbus TCP modules.
 - * Support at most 4 ICP DAS PM-4324 series Power Meters
- Display real-time or historical power data; Provide power data statistics report
- Power data logger and data files send back function supported.
- Built-in IF-THEN-ELSE logic engine for power demand management
- Support Telegram, LINE, WeChat, SMS and Email message notification
- Support Modbus TCP/RTU, SNMP, MQTT, FTP and CGI protocols.
- Support connection with IoT Cloud Platform (Microsoft Azure, IBM Bluemix, Amazon Web Services) and IoTstar Cloud Management Software
- Support 4G wireless data communication
- Complete information security protection mechanism - HTTPS, VPN, SNMP v3, SFTP, FTPS, and Blacklist/Whitelist.



PMC-284xM is an Advanced IIoT Power Meter Concentrator designed by ICP DAS for applications in the era of IoT and cloud computing. It allows flexible integration with ICP DAS power meters via RS-485 or Ethernet, and supports functions including power data collection, energy usage analysis, data logging, power demand management, and remote alarm notification. With a user-friendly and intuitive web-based interface, users can complete system setup and monitoring in just a few clicks—no programming required.

PMC-284xM can work in conjunction with ICP DAS smart power meters and uses IF-THEN-ELSE logic rules and alarm notifications, allowing it to perform advanced power demand management and load shedding operations when needed.

To ensure data integrity and system protection, PMC-284xM supports multiple security mechanisms including VPN Client, SNMP v3, SFTP, FTPS, and HTTPS. These encrypted communication protocols help meet the high standards of information security required in IoT-based cloud power monitoring systems.

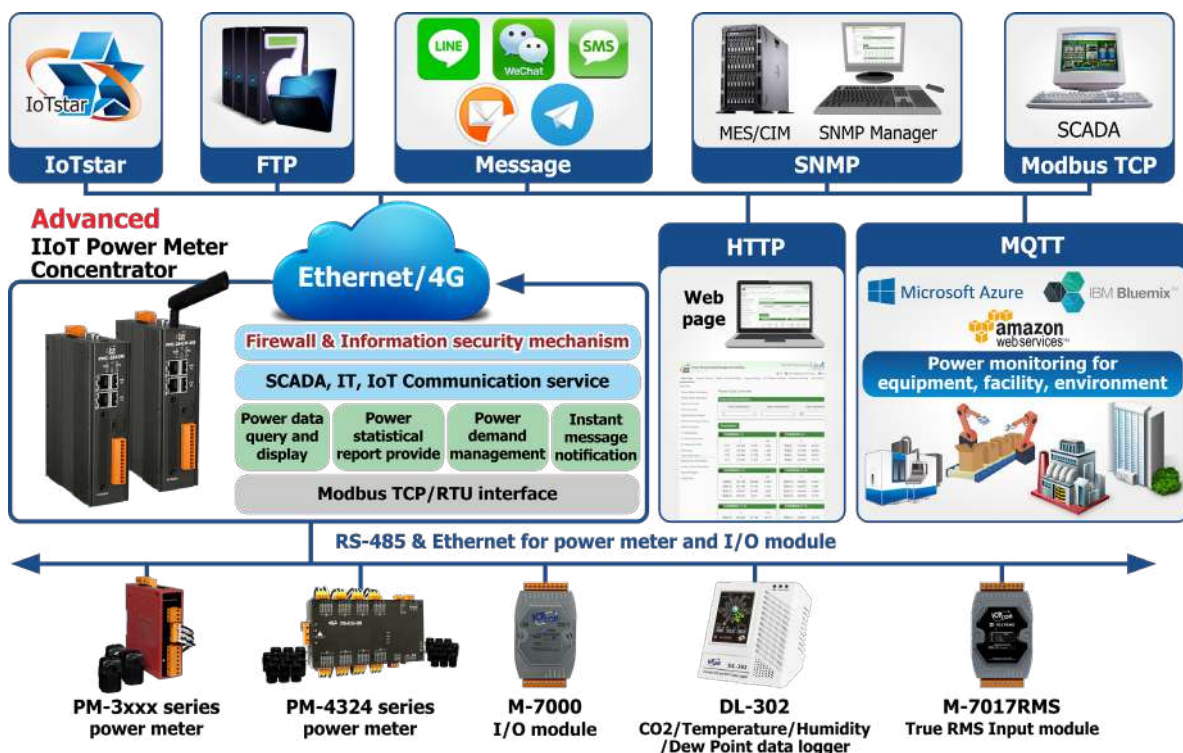

To meet increasing security requirements in Industrial IoT systems, ICP DAS has launched the Advanced IIoT Power Meter Concentrator: PMC-284xM series as an advanced upgrade of the PMC-5231x/224x. In addition to inheriting the core features of the previous generation, PMC-284xM enhances its protection capabilities by offering a wide range of security mechanisms and encrypted protocols as listed below:

■ Network Security

The PMC-284xM series features VPN communication capabilities (supports 4 VPN protocols: PPTP, L2TP, OpenVPN, and SoftEther), allowing users to establish a secure communication tunnel between the PMC controller and external networks. By operating within a protected VPN environment, PMC-284xM and its connected power meters are effectively shielded from unauthorized access and external cyber security threats.



■ System Security

As the web interface serves as the main entry point for configuring the system and monitoring connected power meters, its protection is critical. PMC-284xM supports the HTTPS encrypted communication protocol to ensure that all data exchanged between the browser and the controller is secure, preventing sensitive settings and operational commands from being intercepted or tampered with. In addition, it implements SNMP v3 for secure communication and includes a user authentication mechanism to safeguard connections between the PMC-284xM and IT systems, reinforcing access control and system integrity.

■ Data Security

To support secure data handling, PMC-284xM is equipped with a microSD card that enables both periodic and event-driven data logging for connected power meters. Logged data can be automatically transmitted to the back-office via FTPS, or manually retrieved by users through SFTP, FTPS, or a standard web interface. All data transfers are safeguarded using TLS encryption, ensuring the log files remain protected from interception or tampering during transmission.



Identity Authentication Security

To further enhance access security, PMC-284xM implements password authentication for each communication interface. Only administrators who enter the correct credentials can configure and operate the device. Additionally, PMC-284xM supports both blacklist and whitelist settings, allowing users to control which domains or IPs are permitted or denied access. A dynamic blacklist mechanism is also available, which automatically blocks IP addresses that exceed a predefined number of failed login attempts—providing effective defense against brute-force password attacks.



Cloud Backup Mechanism

Despite the robust security mechanisms in place, the possibility of a breach can never be completely eliminated. Therefore, system recovery plays a crucial role in ensuring operational resilience. PMC-284xM supports automatic backup and recovery by connecting to ICP DAS's IoTstar Cloud Management Software. In addition to collecting power meter data and uploading it to a database, IoTstar can also perform automatic backups of the system settings for all connected PMC controllers. If a device is compromised or damaged due to a cyberattack, the original system configuration can be quickly restored to a replacement PMC controller. This minimizes downtime and ensures that system operations can return to normal with minimal disruption or data loss.



The Advanced IIoT Edge Controller - PMC-284xM inherits the features of the original PMC series controllers: perform system setting, power information monitoring by browser, powerful IF-THEN-ELSE logic operation capability for power demand management, connect a variety of power meters, and provide instant messaging notification operation. Now it also features greatly improved information security mechanism. The PMC-284xM is perfect to serve as the operational core of the industrial IoT power monitoring system.

Hardware Specifications

Model	PMC-284xM
System	
CPU	Quad-core ARM CPU, 1.6 GHz/Core
VGA port	Yes (Only for system diagnostic and recovery operations)
SDRAM/Flash	DDR3 2 GB / 8 GB
microSD	Built-in one 4 GB microSD card (support up to 32 GB microSDHC card or 2 TB microSDXC card)
Communication Interface	
Ethernet	RJ-45 x 2, 10/100/1000 Base-TX (Auto-negotiating, Auto MDI/MDI-X)
COM 2	RS-232 (TxD, RxD, GND), non-isolated, Speed: 115200 bps max
COM 3/COM 4	RS-485 (Data+, Data-), Speed: 115200 bps max. Support 2500 VDC isolation.
Module Support	
Local Side	Support ICP DAS XV-board
Remote Side	<ul style="list-style-type: none"> • Support at most 48 modules (Include ICP DAS Modbus Power Meters and Modbus I/O modules) * COM3 and COM4 can connect to Max. 16 Modbus RTU modules individually. * LAN can connect to Max. 16 Modbus TCP modules. * Support at most 4 ICP DAS PM-4324 series Power Meters
Mechanical	
Casing	Metal
Dimensions (W x L x H; mm)	42 x 164 x 129
Installation	Wall Mounting Installation or DIN-Rail Installation (Optional)
Environmental	
Temperature/ Humidity	Operating Temperature: -25 °C to +75 °C; Storage Temperature: -40 °C to +80 °C; 10 to 90% RH, Non-condensing
Power Requirements	
Input Range/ Consumption	12 to 48 VDC Ethernet version: 10 W; -4GE/4GC/3GWA version: 15 W
Mobile Network Communication	
PMC-284xM-4GE	3G : WCDMA 850/900/2100 MHz 4G : FDD LTE: B1/B3/B5/B7/B8/B20 bands (Frequency Band for EMEA, Korea, Thailand, India and Taiwan)
PMC-284xM-4GC	3G : WCDMA: 900/2100 MHz, TD-SCDMA 1900/2100 MHz, CDMA2000 (BC0) 800 MHz 4G : FDD LTE: B1/B3/B8 bands (Frequency Band for China); TDD LTE: B38/B39/B40/B41 bands (Frequency Band for China)

Software Specifications

Function	Description
Operation Interface	<ul style="list-style-type: none"> • Web Page
Power data collection	<ul style="list-style-type: none"> • Power data collection; Real-time and Historical power data displayed • Power data logging and historical power data statistics report provided • PUE information provided and displayed
Power demand management	<ul style="list-style-type: none"> • Built-in IF-THEN-ELSE logic engine for thought-out power demand management • Adjust equipment operation by its power status via Modbus I/O modules • Provide Schedule function to manage the equipment's operation(via the Modbus TCP/RTU protocol) • Provide message notification function via Email, Telegram, LINE and WeChat (4G version PMC provides SMS message notification function)
Integrate with SCADA/ IT/IoT/ System	<ul style="list-style-type: none"> • Support Modbus TCP/RTU, MQTT, SNMP(v2c, v3) & CGI protocols to transmit real-time power data • Power data logging and power data file auto send-back (by FTP protocol) & recovery when network is resumed after disconnection • Support DDNS (Dynamic DNS) system • Support Microsoft Azure, IBM Bluemix and Amazon Web Service • Support ICP DAS IoTstar Cloud software
Information Security Mechanism	<ul style="list-style-type: none"> • Support HTTPS encryption protocol for Web interface operation • Support VPN Client function (PPTP, L2TP, OpenVPN and SoftEther protocols) • Support SNMP v3 encryption protocol to ensure the security of the connection with IT system • Support SFTP & FTPS mechanisms to ensure that file transfers are encrypted through TLS • Support Blacklist and Whitelist setting to filter and exclude the accessible domains

Appearance

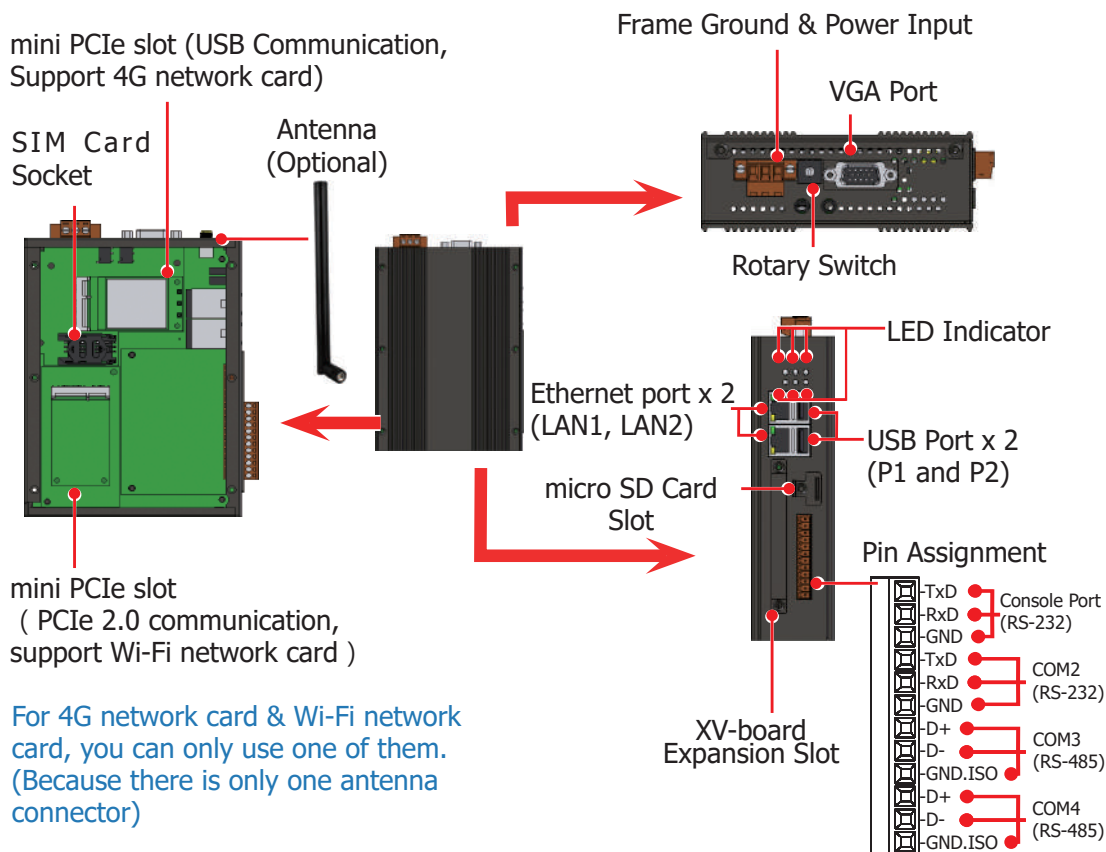

Ordering Information





PMC-2841M CR	Advanced IIoT Power Meter Concentrator (Metal casing)
PMC-2841M-4GE CR	Advanced IIoT Power Meter Concentrator (Metal casing; Built-in 4G Wireless module; Frequency Band for EMEA, Korea, Thailand, India and Taiwan; Asia only)
PMC-2841M-4GC CR	Advanced IIoT Power Meter Concentrator (Metal casing; Built-in 4G Wireless module; Frequency Band for China; Asia only)

4.2 IIoT Power Meter Concentrator



Features

- No extra tool is required, using browsers to perform system operations
- Support at most "24 ICP DAS Modbus Power Meter modules + 8 Modbus I/O modules" (Max. total of 16 TCP type modules)
 - * COM3 and COM4 can connect to Max. 16 Modbus RTU modules individually.
 - * LAN can connect to Max. 16 Modbus TCP modules
 - * Support at most 4 ICP DAS PM-4324 series Power Meters.
- Display real-time or historical power data; Provide power data statistics report.
- Power data logger and data files send back function supported
- Built-in IF-THEN-ELSE logic engine for power demand management
- Support Telegram, LINE, WeChat and Email message notification
- Support Modbus TCP/RTU, SNMP, MQTT, FTP and CGI protocols.
- Support connection with IoT Cloud Platform (Microsoft Azure, IBM Bluemix) and Iotstar Cloud Management Software

PMC-523x(M) is the IIoT Power Meter Concentrator for meeting the trend of energy management in the Industry 4.0 age. It provides flexible integration with the ICP DAS power meters via RS-485 or Ethernet interface, and features various functions such as: measure the power consumption of the devices, energy usage analysis, power data log operation, power demand management and alarm notification functions. PMC-523x(M) offers a user-friendly and intuitive web site interface that allows users to implement the Energy monitoring system just a few clicks away; no programming is required. By working with the power meters, IF-THEN-ELSE logic rule execution ability, and alarm message notification functions, PMC-523x(M) offers more thought-out power demand management functions, and is able to perform load shedding of the devices if required. It also supports the Modbus TCP/RTU, SNMP, FTP, MQTT and CGI protocols for seamless integration with the back-end SCADA/IT/IoT systems.

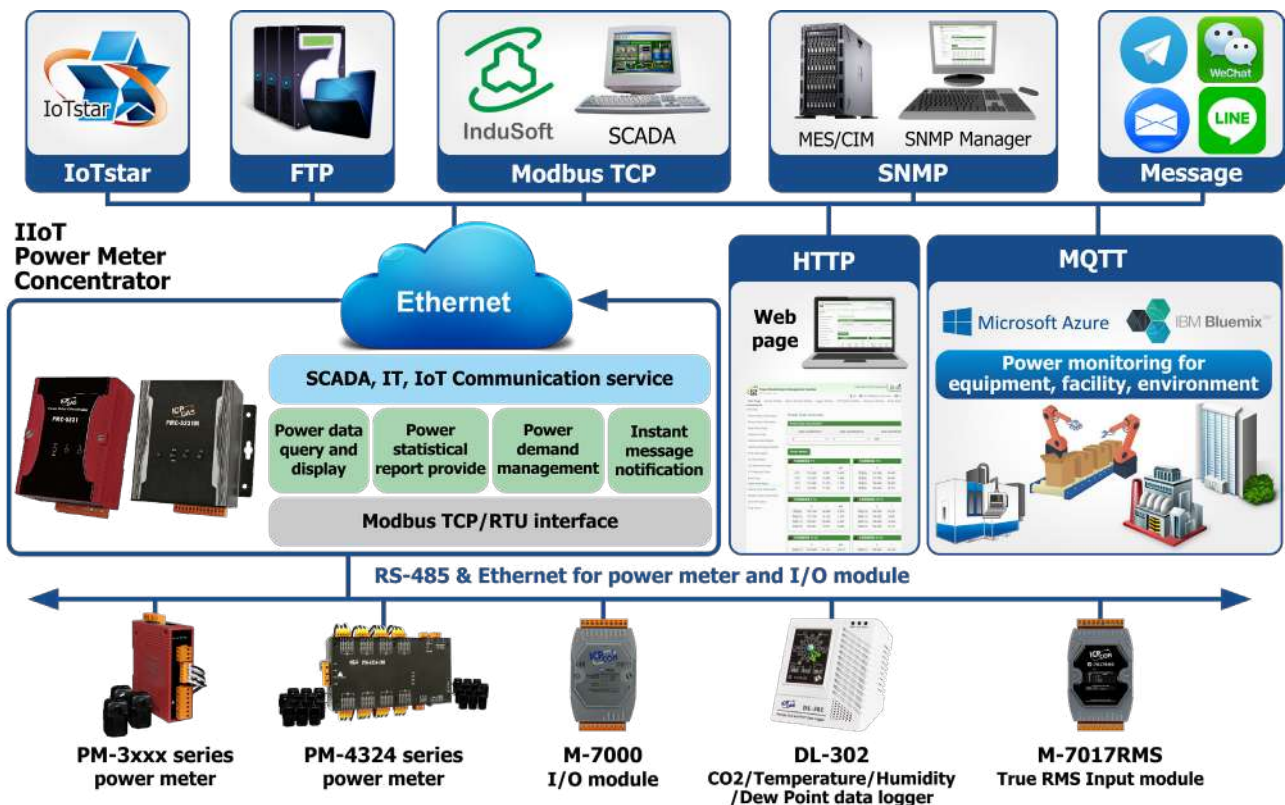

Hardware Specifications

Model	PMC-523x	PMC-523xM
System		
CPU	32-bit ARM CPU, 1 GHz	
VGA port	Yes (Only for system diagnostic and recovery operations)	
microSD	Built-in one 4 GB microSD card (support up to 32 GB microSDHC card)	
Communication Interface		
Ethernet	RJ-45 x 1, 10/100/1000 Base-TX (Auto-negotiating, Auto MDI/MDI-X)	
COM 2	RS-232 (TxD, RxD, GND), non-isolated, Speed: 115200 bps max	
COM 3/COM 4	RS-485 (Data+, Data-), Speed: 115200 bps max. COM 4 provides 2500 VDC isolation.	
Module Support		
Local Side	Support ICP DAS XV-board	
Remote Side	<ul style="list-style-type: none"> • Support at most "24 ICP DAS Modbus Power Meters + 8 Modbus I/O modules" (Max. total of 16 Modbus TCP type modules) * COM3 and COM4 can connect to Max. 16 Modbus RTU modules individually. * LAN can connect to Max. 16 Modbus TCP modules. * Support at most 4 ICP DAS PM-4324 series Power Meters) 	
Mechanical		
Casing/ Dimensions (W x L x H; mm)	Plastic ; 91 x 132 x 52	Metal ; 117 x 126 x 58
Installation	DIN-Rail Installation	Wall Mounting/DIN-Rail Installation
Environmental		
Temperature/ Humidity	Operating Temperature: -25 °C to +75 °C; Storage Temperature: -40 °C to +80 °C; 10 to 90% RH, Non-condensing	
Power Requirements		
Input Range/ Consumption	+12 to +48 VDC; 4.8 W	

Software Specifications

Function	Description
Operation Interface	<ul style="list-style-type: none"> • Web Page
Power data collection	<ul style="list-style-type: none"> • Power data collection; Real-time and Historical power data displayed • Power data logging and historical power data statistics report provided • PUE information provided and displayed
Power demand management	<ul style="list-style-type: none"> • Built-in IF-THEN-ELSE logic engine for thought-out power demand management • Adjust equipment operation by its power status via Modbus I/O modules • Provide Schedule function to manage the equipment's operation(via the Modbus TCP/RTU protocol) • Provide message notification function via Email, Telegram and LINE (PMC-5236 also provides WeChat message notification function)
Integrate with SCADA/ IT/IoT/ System	<ul style="list-style-type: none"> • Support Modbus TCP/RTU, MQTT, SNMP(v1, v2c), CGI protocols to transmit real-time power data • Power data logging and power data file auto send-back (by FTP protocol) & recovery when network is resumed after disconnection • Support DDNS (Dynamic DNS) system • Support Microsoft Azure, IBM Bluemix IoT Cloud platforms • Support ICP DAS IoTstar Cloud software

Appearance

PMC-523x

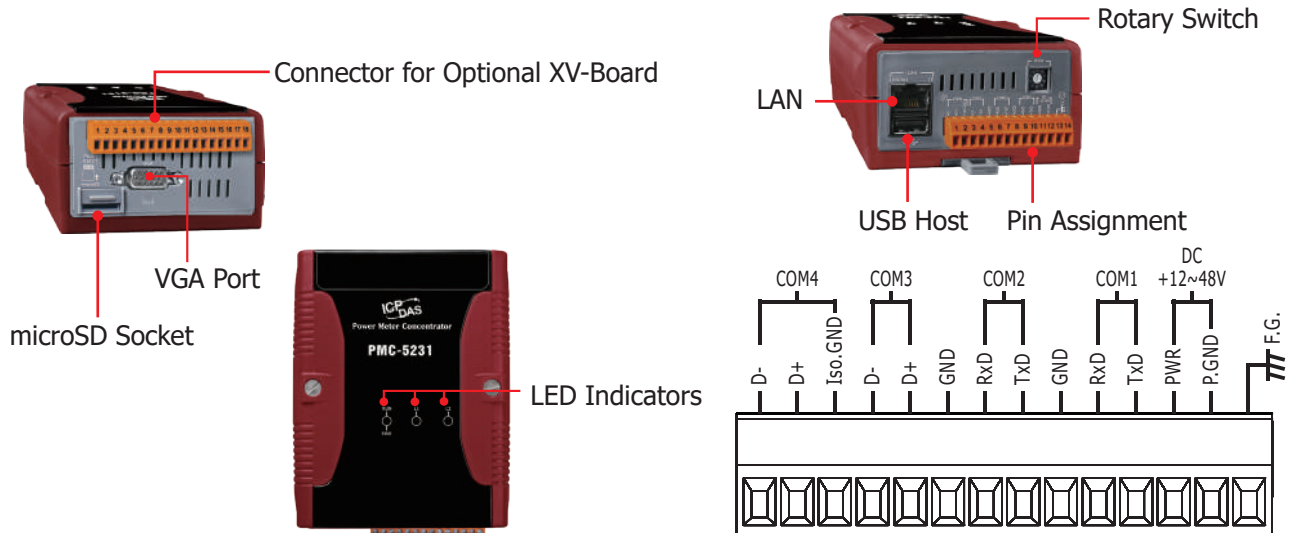

PMC-523xM

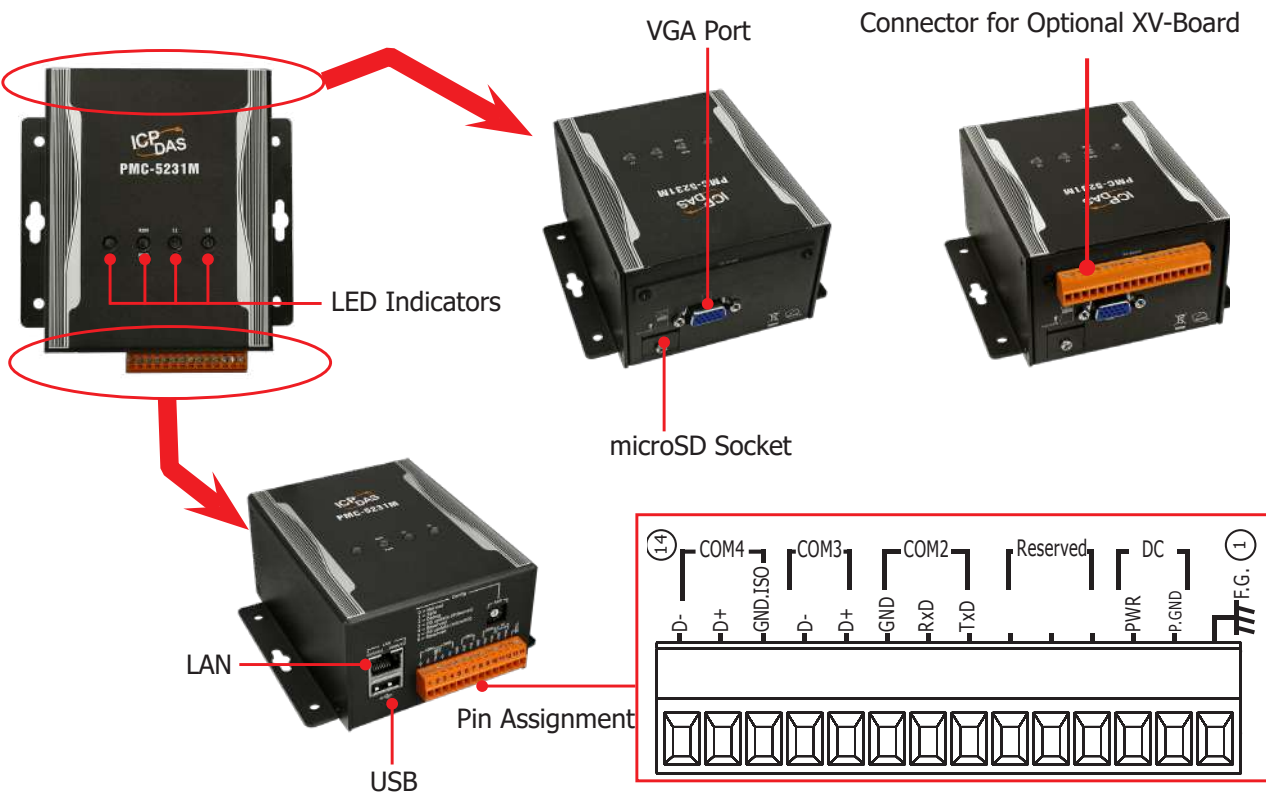

Ordering Information

PMC-5231 CR	IIoT Power Meter Concentrator (Plastic casing;)
PMC-5236 CR	IIoT Power Meter Concentrator (Plastic casing; Additional support for WeChat Message Sending)
PMC-5231M CR	IIoT Power Meter Concentrator (Metal casing)
PMC-5236M CR	IIoT Power Meter Concentrator (Metal casing; Additional support for WeChat Message Sending)



Features

- No extra tool is required, using browsers to perform system operations
- Support at most "24 ICP DAS Modbus Power Meter modules + 8 Modbus I/O modules" (Max. total of 16 TCP type modules)
 - * COM3 and COM4 can connect to Max. 16 Modbus RTU modules individually.
 - * LAN can connect to Max. 16 Modbus TCP modules.
 - * Support at most 4 ICP DAS PM-4324 series Power Meters.
- Display real-time or historical power data; Provide power data statistics report.
- Power data logger and data files send back function supported.
- Built-in IF-THEN-ELSE logic engine for power demand management
- Support Telegram, LINE, WeChat and Email message notification.
- Support Modbus TCP/RTU, SNMP, MQTT, FTP and CGI protocols.
- Support connection with IoT Cloud Platform (Microsoft Azure, IBM Bluemix) and IoTstar Cloud Management Software

PMC-224xM is the IIoT Power Meter Concentrator for meeting the trend of energy management in the Industry 4.0 age. It provides flexible integration with the ICP DAS power meters via RS-485 or Ethernet interface, and features various functions such as: measure the power consumption of the devices, energy usage analysis, power data log operation, power demand management and alarm notification functions. PMC-224xM offers a user-friendly and intuitive web site interface that allows users to implement the Energy monitoring system just a few clicks away; no programming is required. By working with the power meters, IF-THEN-ELSE logic rule execution ability, and alarm message notification functions, PMC-224xM offers more thought-out power demand management functions, and is able to perform load shedding of the devices if required. It also supports the Modbus TCP/RTU, SNMP, FTP, MQTT and CGI protocols for seamless integration with the back-end SCADA/IT/IoT systems.

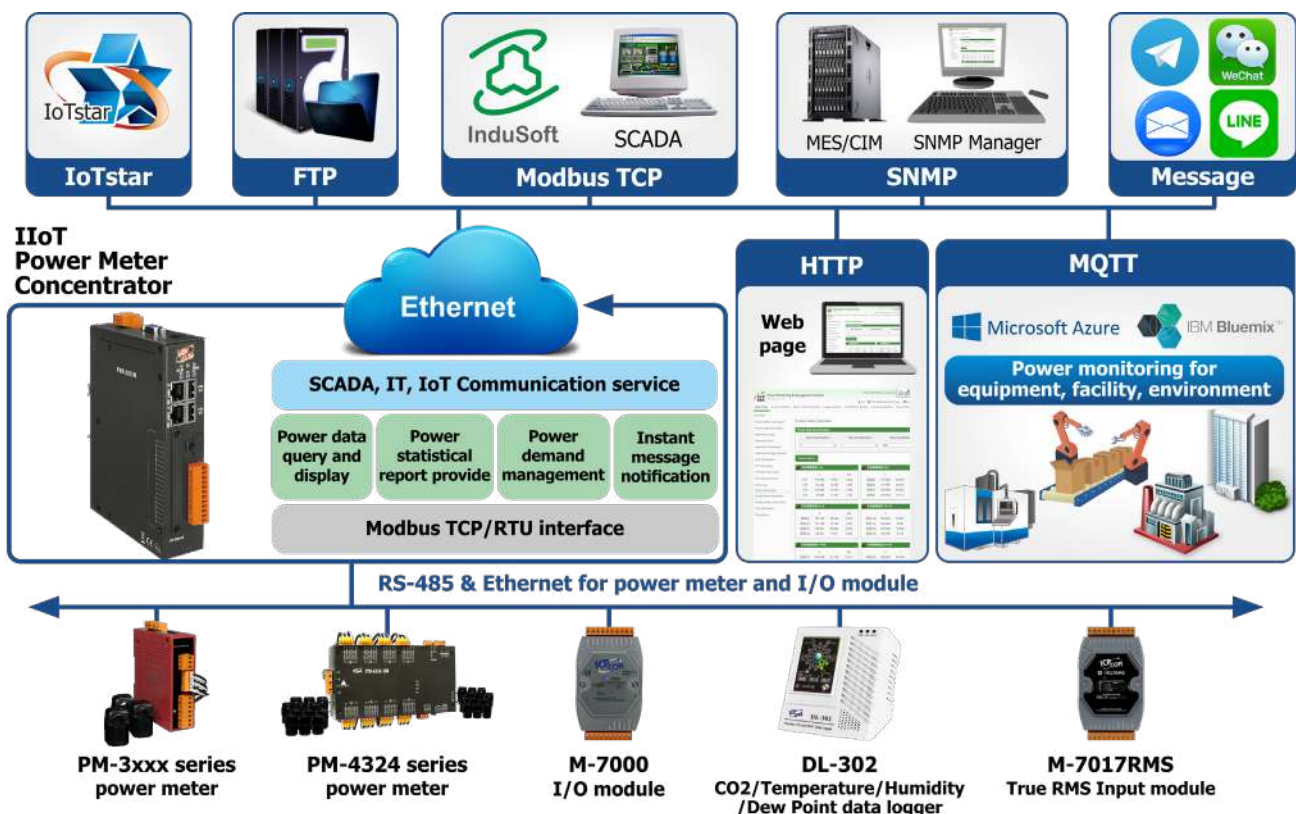

Hardware Specifications

Model	PMC-224x
System	
CPU	32-bit ARM CPU, 1 GHz
VGA port	Yes (Only for system diagnostic and recovery operations)
microSD	Built-in one 4 GB microSD card (support up to 32 GB microSDHC card)
Communication Interface	
Ethernet	RJ-45 x 2, 10/100/1000 Base-TX (Auto-negotiating, Auto MDI/MDI-X)
COM 2	RS-232 (TxD, RxD, GND), non-isolated, Speed: 115200 bps max
COM 3/COM 4	RS-485 (Data+, Data-), Speed: 115200 bps max. Support 2500 VDC isolation.
Module Support	
Local Side	Support ICP DAS XV-board
Remote Side	<ul style="list-style-type: none"> Support at most "24 ICP DAS Modbus Power Meters + 8 Modbus I/O modules" (Max. 16 Modbus TCP modules) * COM3 and COM4 interface can connect to Max. 16 Modbus RTU modules individually. * LAN can connect to Max. 16 Modbus TCP modules. * Support at most 4 ICP DAS PM-4324 series Power Meters
Mechanical	
Casing	Metal
Dimensions (W x L x H; mm)	35 × 167 × 119
Installation	Wall Mounting Installation or DIN-Rail Installation (Optional)
Environmental	
Temperature/ Humidity	Operating Temperature: -25 °C to +75 °C; Storage Temperature: -40 °C to +80 °C; 10 to 90% RH, Non-condensing
Power Requirements	
Input Range/ Consumption	+12 to +48 VDC; 4.8 W

Software Specifications

Function	Description
Operation Interface	<ul style="list-style-type: none"> Web Page
Power data collection	<ul style="list-style-type: none"> Power data collection; Real-time and Historical power data displayed Power data logging and historical power data statistics report provided PUE information provided and displayed
Power demand management	<ul style="list-style-type: none"> Built-in IF-THEN-ELSE logic engine for thought-out power demand management Adjust equipment operation by its power status via Modbus I/O modules Provide Schedule function to manage the equipment's operation(via the Modbus TCP/RTU protocol) Provide message notification function via Email, Telegram and LINE (PMC-2246M also provides WeChat message notification function)
Integrate with SCADA/ IT/IoT/ System	<ul style="list-style-type: none"> Support Modbus TCP/RTU, MQTT, SNMP(v1, v2c), CGI protocols to transmit real-time power data Power data logging and power data file auto send-back (by FTP protocol) & recovery when network is resumed after disconnection Support DDNS (Dynamic DNS) system Support Microsoft Azure, IBM Bluemix IoT Cloud platforms Support ICP DAS IoTstar Cloud software

Appearance

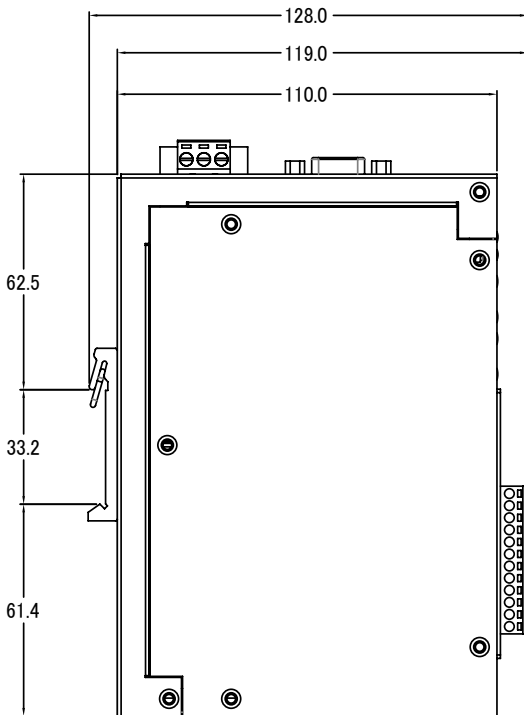
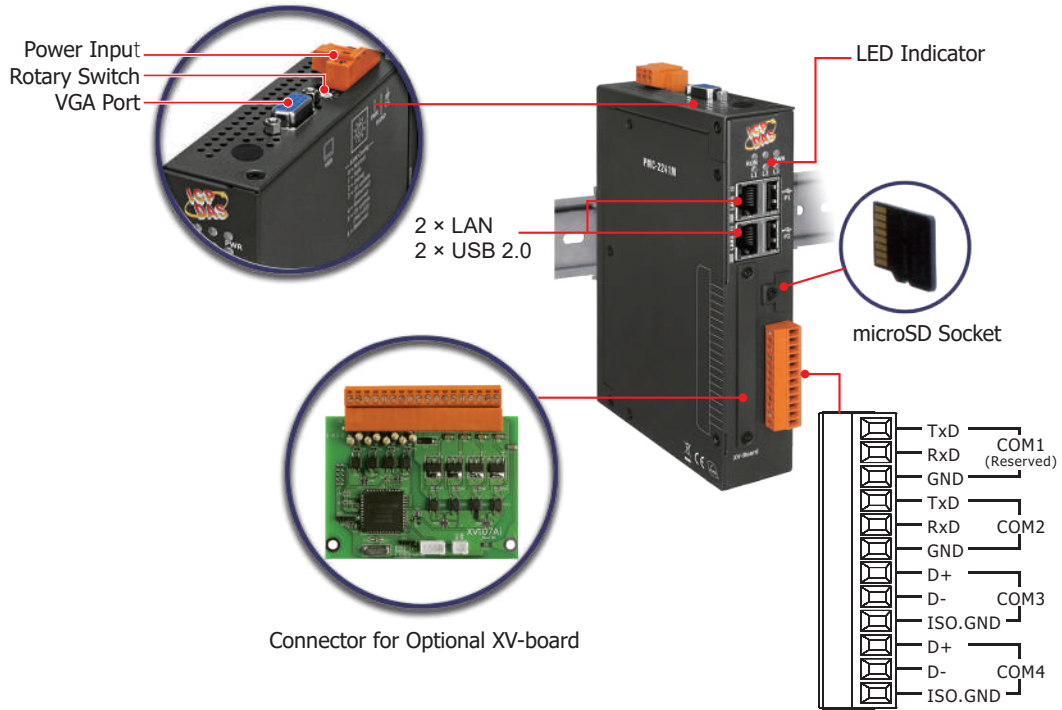

Left Side View

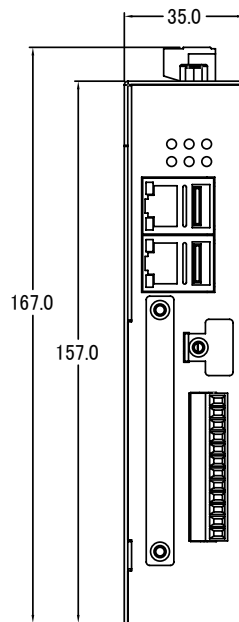

Front View

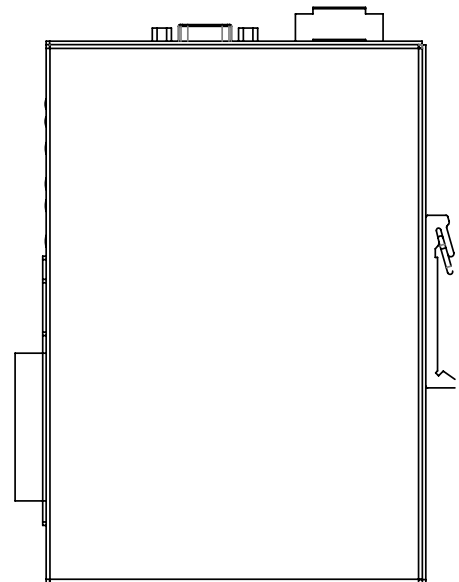

Right Side View

Ordering Information

PMC-2241M CR	IIoT Power Meter Concentrator (Metal casing)
PMC-2246M CR	IIoT Power Meter Concentrator (Metal casing; Additional support for WeChat Message Sending)



Features

- No extra software tool is required, using browsers to perform system operations
- Support at most "24 ICP DAS Modbus Power Meter modules + 8 Modbus I/O modules" (Max. total of 16 TCP type modules)
 - * COM3 and COM4 can connect to Max. 16 Modbus RTU modules individually.
 - * LAN can connect to Max. 16 Modbus TCP modules.
 - * Support at most 4 ICP DAS PM-4324 series Power Meters
- Display real-time or historical power data; Provide power data statistics report
- Power data logger and data files send back function supported.
- Built-in IF-THEN-ELSE logic engine for power demand management
- Support Telegram, LINE, WeChat, SMS and Email message notification.
- Support Modbus TCP/RTU, SNMP, MQTT, FTP and CGI protocols
- Support connection with IoT Cloud Platform (Microsoft Azure, IBM Bluemix) and IoTstar Cloud Management Software
- Support 4G wireless data communication



PMC-523xM-4GE/4GC is the IIoT Power Meter Concentrator for meeting the trend of energy management in the Industry 4.0 age. It provides flexible integration with the ICP DAS power meters via RS-485 or Ethernet interface, and features various functions such as: measure the power consumption of the devices, energy usage analysis, power data log operation, power demand management and alarm notification functions. PMC-523xM-4GE/4GC offers a user-friendly and intuitive web site interface that allows users to implement the Energy monitoring system just a few clicks away; no programming is required. By working with the power meters, IF-THEN-ELSE logic rule execution ability, and alarm message notification functions, PMC-523xM-4GE/4GC offers more thought-out power demand management functions, and is able to perform load shedding of the devices if required. It also supports the Modbus TCP/RTU, SNMP, FTP, MQTT and CGI protocols for seamless integration with the back-end SCADA/IT/IoT systems.

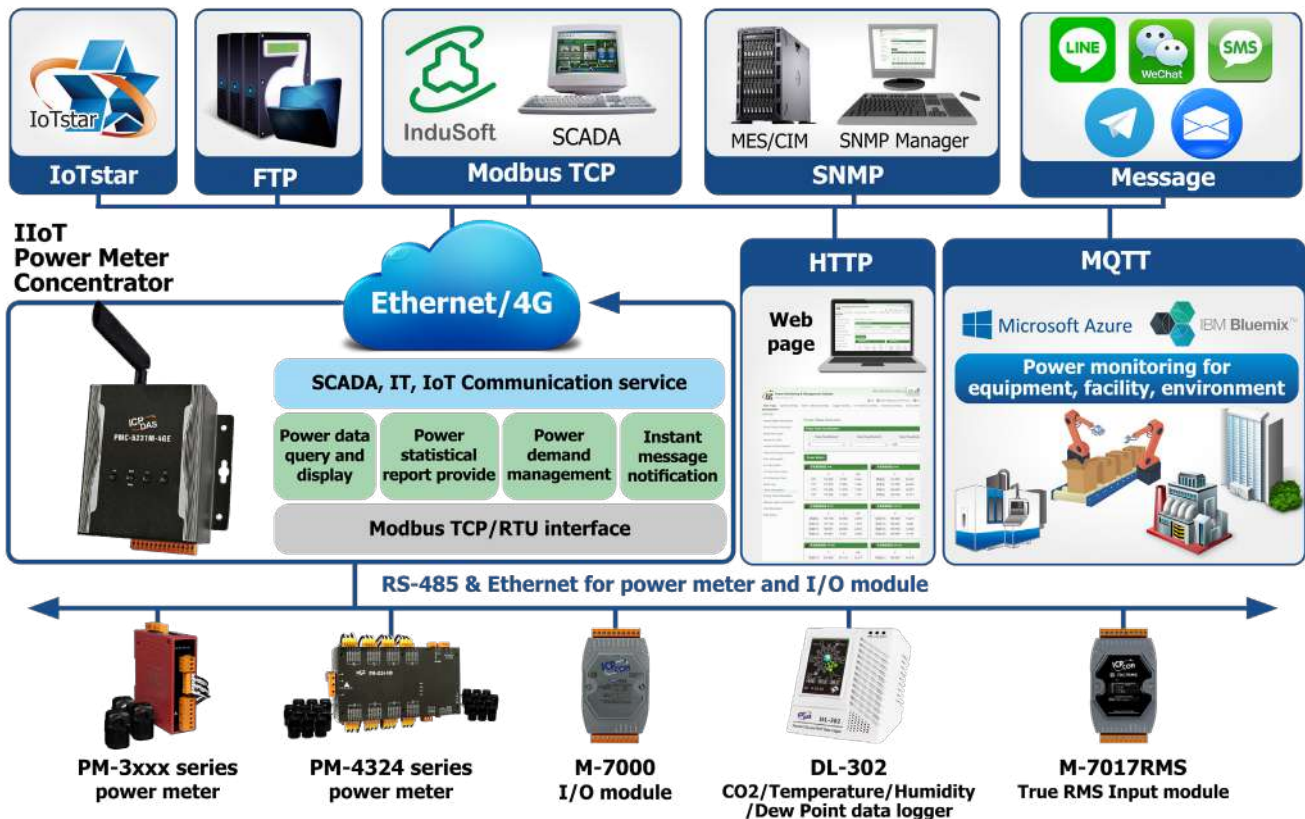

Hardware Specifications

Model	PMC-523xM-4GE/4GC
System	
CPU	32-bit ARM CPU, 1 GHz
VGA port	Yes (Only for system diagnostic and recovery operations)
microSD	Built-in one 4 GB microSD card (support up to 32 GB microSDHC card)
Communication Interface	
Ethernet	RJ-45 x 1, 10/100/1000 Base-TX (Auto-negotiating, Auto MDI/MDI-X)
COM 2	RS-232 (TxD, RxD, GND), non-isolated, Speed: 115200 bps max
COM 3/COM 4	RS-485 (Data+, Data-), Speed: 115200 bps max. COM 4 provides 2500 VDC isolation.
Module Support	
Local Side	Support ICP DAS XV-board
Remote Side	<ul style="list-style-type: none"> Support at most "24 ICP DAS Modbus Power Meters + 8 Modbus I/O modules" (Max. 16 Modbus TCP modules) * COM3 and COM4 can connect to Max. 16 Modbus RTU modules individually. * LAN can connect to Max. 16 Modbus TCP modules. * Support at most 4 ICP DAS PM-4324 series Power Meters
Mechanical	
Casing/ Dimensions (W x L x H; mm)	Metal ; 117 x 126 x 58
Installation	Wall Mounting/DIN-Rail Installation
Environmental	
Temperature/ Humidity	Operating Temperature: -25 °C to +75 °C; Storage Temperature: -40 °C to +80 °C; 10 to 90% RH, Non-condensing
Power Requirements	
Input Range/ Consumption	+12 to +48 VDC; 6.5 W
WISE-523xM-4GE	3G: WCDMA 850/900/2100 MHz 4G: FDD LTE: B1/B3/B5/B7/B8/B20 bands (Frequency Band for EMEA, Korea, Thailand, India and Taiwan)
WISE-523xM-4GC	3G: WCDMA: 900/2100 MHz, TD-SCDMA 1900/2100 MHz, CDMA2000 (BC0) 800 MHz 4G: FDD LTE: B1/B3/B8 bands (Frequency Band for China); TDD LTE: B38/B39/B40/B41 bands (Frequency Band for China)

Software Specifications

Function	Description
Operation Interface	<ul style="list-style-type: none"> Web Page
Power data collection	<ul style="list-style-type: none"> Power data collection; Real-time and Historical power data displayed Power data logging and historical power data statistics report provided PUE information provided and displayed
Power demand management	<ul style="list-style-type: none"> Built-in IF-THEN-ELSE logic engine for thought-out power demand management Adjust equipment operation by its power status via Modbus I/O modules Provide Schedule function to manage the equipment's operation(via the Modbus TCP/RTU protocol) Provide message notification function via Email, Telegram, LINE and SMS (PMC-xxx6 also provides WeChat message notification function)
Integrate with SCADA/ IT/IoT/ System	<ul style="list-style-type: none"> Support Modbus TCP/RTU, MQTT, SNMP(v1, v2c), CGI protocols to transmit real-time power data Power data logging and power data file auto send-back (by FTP protocol) & recovery when network is resumed after disconnection Support DDNS (Dynamic DNS) system Support Microsoft Azure, IBM Bluemix IoT Cloud platforms Support ICP DAS IoTstar Cloud software

Appearance

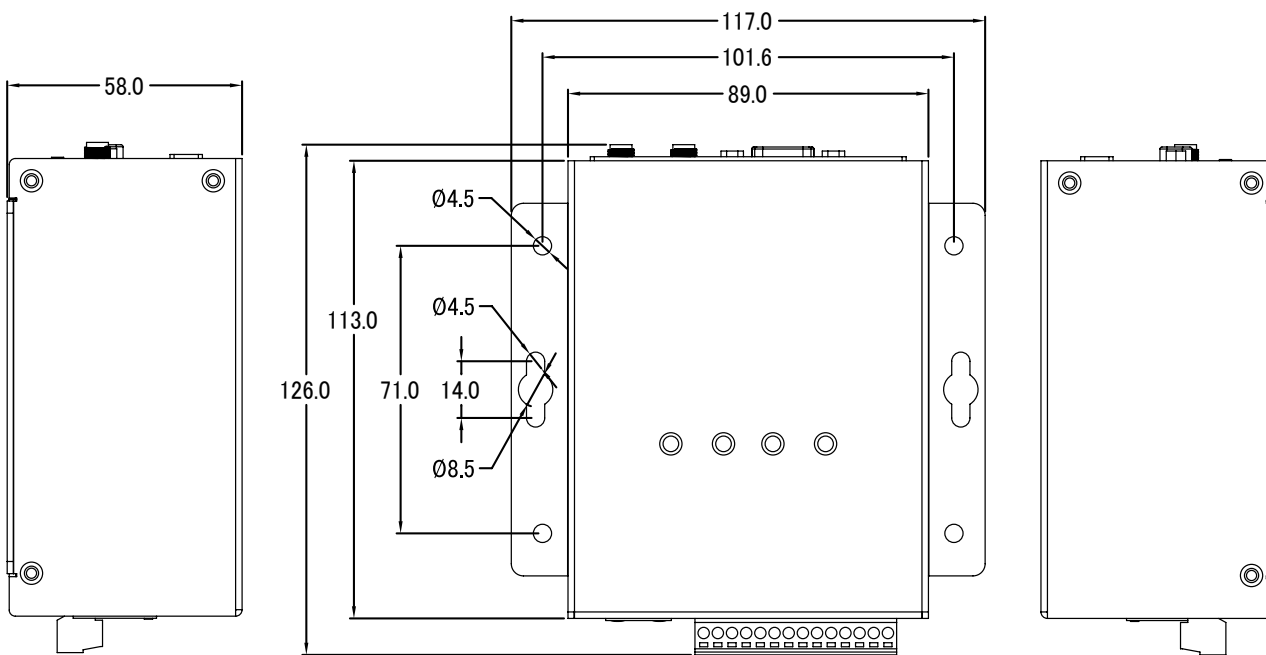
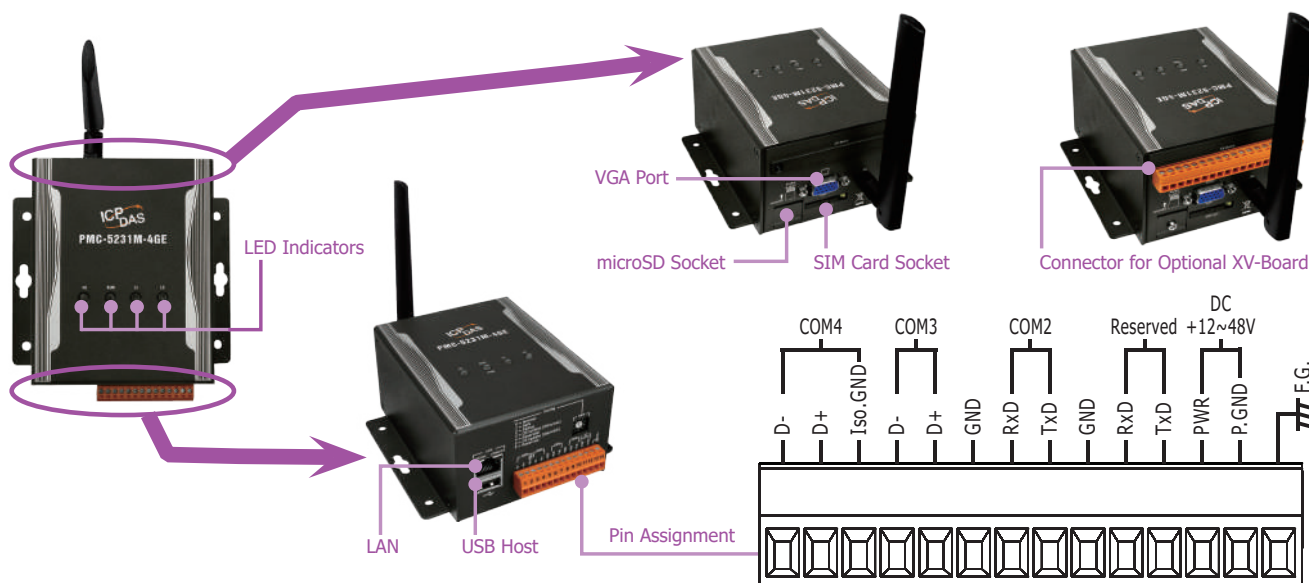

Left Side View

Front View

Right Side View

Ordering Information

PMC-5231M-4GE CR	IIoT Power Meter Concentrator (Metal casing; Built-in 4G Wireless module; Frequency Band for EMEA, Korea, Thailand, India and Taiwan)
PMC-5231M-4GC CR	IIoT Power Meter Concentrator (Metal casing; Built-in 4G Wireless module; Frequency Band for China)
PMC-5236M-4GE CR	IIoT Power Meter Concentrator (Metal casing; Built-in 4G Wireless module; Frequency Band for EMEA, Korea, Thailand, India and Taiwan; Additional support for WeChat Message Sending;)
PMC-5236M-4GC CR	IIoT Power Meter Concentrator (Metal casing; Built-in 4G Wireless module; Frequency Band for China; Additional support for WeChat Message Sending;)

4.3 Power Meter Concentrator with Display

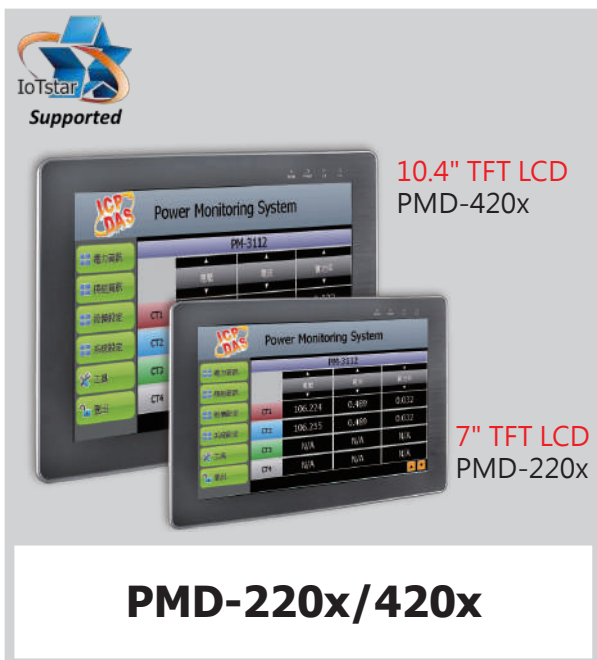

Features

- No extra tool is required, using browsers or touch panel to perform system operations
- Support at most "24 ICP DAS Modbus Power Meter modules + 8 Modbus I/O modules" (Max. total of 16 TCP type modules)
 - * COM1 and COM2 can connect to Max. 16 Modbus RTU modules individually.
 - * LAN can connect to Max. 16 Modbus TCP modules.
 - * Support at most 4 ICP DAS PM-4324 series Power Meters.
- 7"/10.4" TFT LCD (with Touch Panel) & PoE (Power over Ethernet) supported
- Display real-time or historical power data; Provide power data statistics report.
- Power data logger and data files send back function supported
- Built-in IF-THEN-ELSE logic engine for power demand management
- Support Telegram, LINE, WeChat and Email message notification
- Support Modbus TCP/RTU, SNMP, MQTT, FTP and CGI protocols.
- Support connection with IoT Cloud Platform (Microsoft Azure, IBM Bluemix) and IoTstar Cloud Management Software



PMD is the IIoT Power Meter Concentrator for meeting the trend of energy management in the Industry 4.0 age. It provides flexible integration with the ICP DAS power meters via RS-485 or Ethernet interface, and features various functions such as: measure the power consumption of the devices, energy usage analysis, power data log operation, power demand management and alarm notification functions. PMD offers a user-friendly and intuitive web site interface that allows users to implement the Energy monitoring system just a few clicks away; no programming is required. PMD is also equipped with the Touch Panel for viewing the power data and performing system setting at the local side. By working with the power meters, IF-THEN-ELSE logic rule execution ability, and alarm message notification functions, PMD offers more thought-out power demand management functions, and is able to perform load shedding of the devices if required. It also supports the Modbus TCP/RTU, SNMP, FTP, MQTT and CGI protocols for seamless integration with the back-end SCADA/IT/IoT systems.

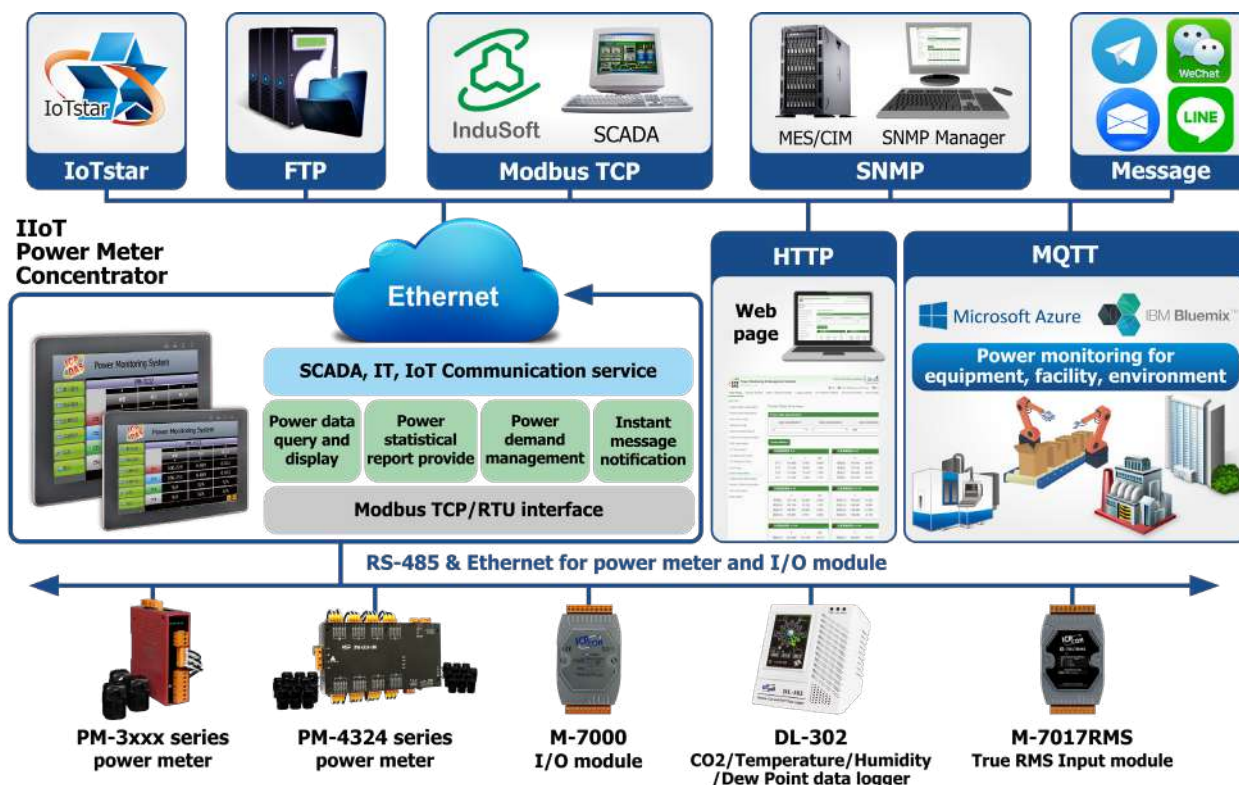

Hardware Specifications

Model	PMD-220x	PMD-420x
System		
CPU	32-bit ARM CPU (1 GHz)	
microSD	Built-in one 4 GB micro SDHC card (support up to 32 GB)	Built-in one 4 GB SDHC card (support up to 32 GB)
LCD		
Diagonal Size / Resolution	7" (16:9); 800 x 480	10.4" (4:3); 800 x 600
Brightness (cd/2) / Contrast Ratio	400; 500:1	
LED Backlight Life (hrs)	20,000	50,000
Touch Panel	4-wire, resistive type; light transmission: 80 %	5-wire, resistive type; light transmission: 80 %
Communication Interface		
Ethernet	RJ-45 x 1, 10/100/1000 Base-TX (Auto-negotiating, Auto MDI/MDI-X)	
COM1/COM 2	RS-485 (Data+, Data-) (9-wire DB9 connector); Speed:115200 bps max. Support 2500 VDC isolation.	
COM 3	-	RS-485 (Data+, Data-), Speed: 115200 bps max. 2500 VDC isolation.
Module Support		
Remote Side	<ul style="list-style-type: none"> Support at most "24 ICP DAS Modbus Power Meters + 8 Modbus I/O modules" (Max. 16 Modbus TCP modules) * COM1 and COM2 can connect to Max. 16 Modbus RTU modules individually * LAN can connect to Max. 16 Modbus TCP modules. * Support at most 4 ICP DAS PM-4324 series Power Meter 	
Mechanical		
Casing	Metal	
Dimensions (W x L x H; mm)	213 x 44 x 148	291 x 54 x 229
Installation	Panel Mounting	
Panel Cut-Out (W x H ; mm)	197 x 133, +/- 1	277 x 215, +/- 1
Ingress Protection	Front panel: NEMA 4/IP65	
Environmental		
Temperature/ Humidity	Operating Temperature: -10 ° C to +60 ° C; Storage Temperature: -20 ° C to +70 ° C; 10 to 90% RH, Non-condensing	
Power Requirements		
Input Range/	+12 to +48 VDC	
Consumption	Power from PoE (IEEE 802.3af); 6W	Power from PoE (IEEE 802.3af); 13W

Software Specifications

Function	Description
Operation Interface	<ul style="list-style-type: none"> Web Page & Touch Screen
Power data collection	<ul style="list-style-type: none"> Power data collection; Real-time and Historical power data displayed Power data logging and historical power data statistics report provided PUE information provided and displayed
Power demand management	<ul style="list-style-type: none"> Built-in IF-THEN-ELSE logic engine for thought-out power demand management Adjust equipment operation by its power status via Modbus I/O modules Provide Schedule function to manage the equipment's operation(via the Modbus TCP/RTU protocol) Provide message notification function via Email, Telegram and LINE (PMD-x206 also provides WeChat message notification function)
Integrate with SCADA/ IT/IoT/ System	<ul style="list-style-type: none"> Support Modbus TCP/RTU, MQTT, SNMP(v1, v2c), CGI protocols to transmit real-time power data Power data logging and power data file auto send-back (by FTP protocol) & recovery when network is resumed after disconnection Support DDNS (Dynamic DNS) system Support Microsoft Azure, IBM Bluemix IoT Cloud platforms Support ICP DAS IoTstar Cloud software

Appearance

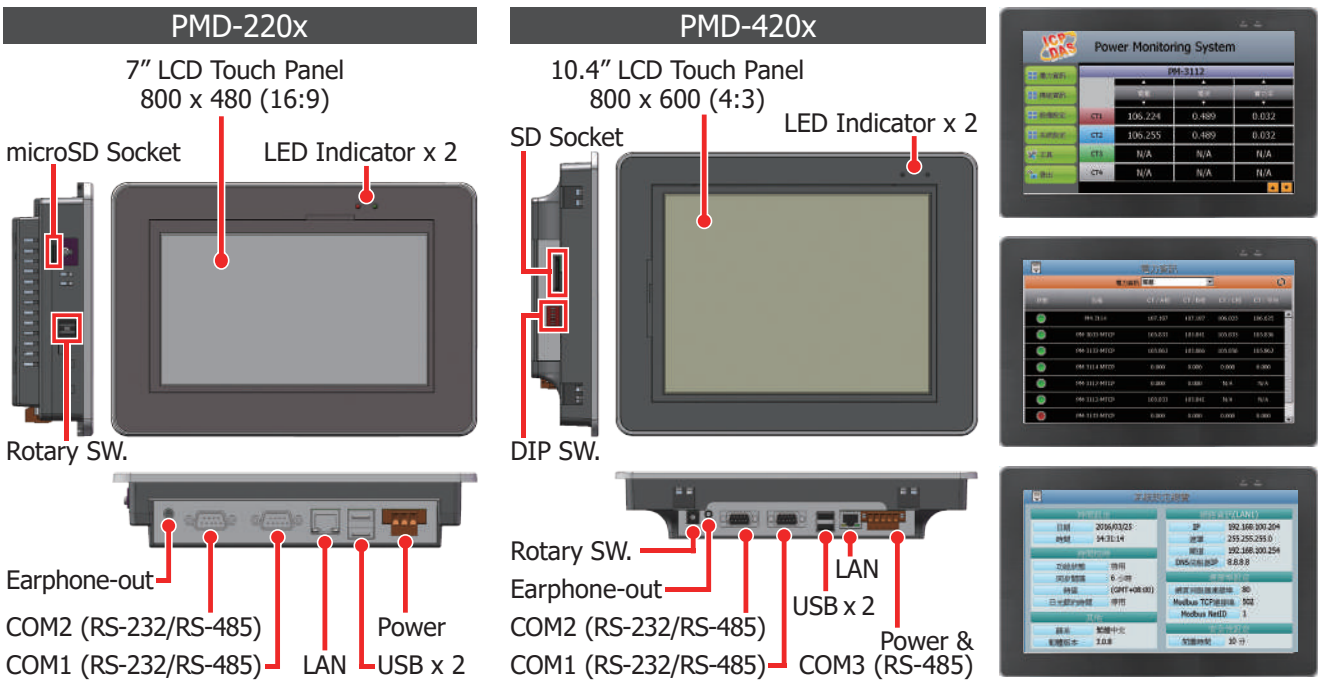

Ordering Information

PMD-2201-EN CR	IIoT Power Meter Concentrator with 7" Display (English) (Metal casing)
PMD-4201-EN CR	IIoT Power Meter Concentrator with 10.4" Display (English) (Metal casing)
PMD-2206-EN CR	IIoT Power Meter Concentrator with 7" Display (English) (Metal casing; Additional support for WeChat Message Sending)
PMD-4206-EN CR	IIoT Power Meter Concentrator with 10.4" Display (English) (Metal casing; Additional support for WeChat Message Sending)

4.4 IIoT iWSN Power Meter Concentrator



PMC-224xM-iWSN
(Dual LAN Ports)

Features

- No extra tool is required, using browsers to perform system operations
- Up to 3 iWSN-200 iWSN data concentrators be connected, supporting up to 93 ICP DAS iWSN wireless modules.
- Supported iWSN wireless module types:
 - * Power meter : iWSN-9603
 - * Signal sensing module : iWSN-110X, iWSN-121A, iWSN-1310.
- Display real-time or historical power data; Provide power data statistics report.
- Power data logger and data files send back function supported
- Built-in IF-THEN-ELSE logic engine for power demand management
- Support Telegram, LINE, WeChat and Email message notification
- Support Modbus TCP/RTU, SNMP, MQTT, FTP and CGI protocols.
- Support connection with IoT Cloud Platform (Microsoft Azure, IBM Bluemix) and IoTstar Cloud Management Software



PMC-224xM-iWSN serves as an iWSN Wireless Power Meter Concentrator to meet the needs of energy management in the Industry 4.0 era. It allows flexible integration with ICP DAS iWSN wireless power meters via iWSN-200 data concentrator, and offers a range of functions including device power consumption measurement, energy usage analysis, power data logging, power demand management and alarm notification. PMC-224xM-iWSN offers a user-friendly and intuitive web site interface that enables users to easily implement an Energy monitoring system with just a few clicks; no programming is required. By working with iWSN power meters, incorporating IF-THEN-ELSE logic rule execution capabilities, and providing alarm message notification functions, PMC-224xM-iWSN delivers advanced power demand management functions. In addition, it supports a wide range of network protocols including Modbus TCP/RTU, SNMP, FTP and MQTT, enabling seamlessly connection with back-end SCADA/IT/IoT systems. The PMC-224xM-iWSN can also connect with ICP DAS IoTstar IoT cloud management software, further enhancing its capability to integrate into diverse IT/IoT environments.

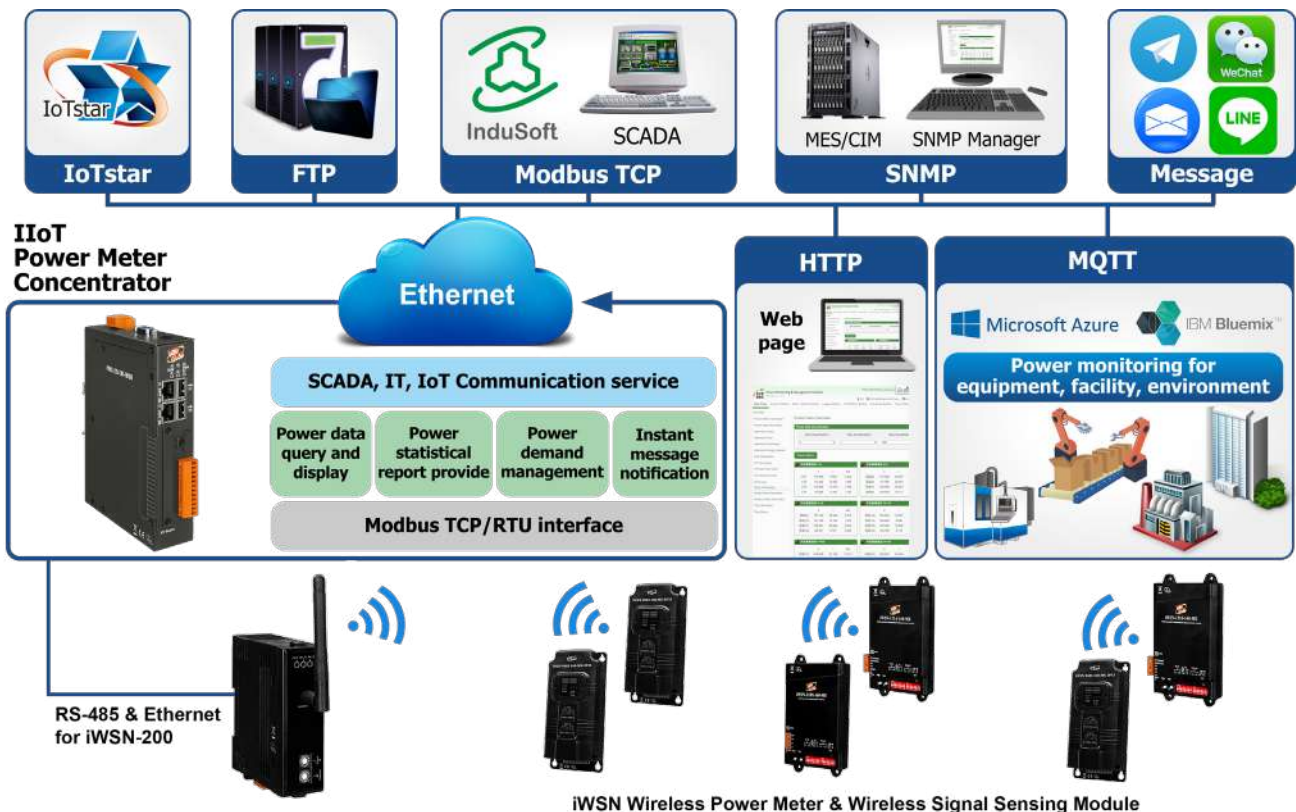

Hardware Specifications

Model	PMC-224xM-iWSN
System	
CPU	32-bit ARM CPU, 1 GHz
VGA port	Yes (Only for system diagnostic and recovery operations)
microSD	Built-in one 4 GB microSD card (support up to 32 GB microSDHC card)
Communication Interface	
Ethernet	RJ-45 x 2, 10/100/1000 Base-TX (Auto-negotiating, Auto MDI/MDI-X)
COM 2	RS-232 (TxD, RxD, GND), non-isolated, Speed: 115200 bps max
COM 3/COM 4	RS-485 (Data+, Data-), Speed: 115200 bps max. Support 2500 VDC isolation.
Module Support	
Power Meter & I/O Module	<ul style="list-style-type: none"> Up to 3 iWSN-200 iWSN data concentrators be connected, and support as most 93 ICP DAS iWSN wireless modules. iWSN wireless module supported types: <ul style="list-style-type: none"> * Power meter: iWSN-9603 * Signal sensing module: iWSN-110X, iWSN-121A and iWSN-1310 <p>Please note: PMC-224xM-iWSN only supports iWSN wireless modules. It can not connect with ICP DAS PM-3xxx/PM-4xxx power meter, XV-Board or other wired Modbus I/O module.</p>
Mechanical	
Casing	Metal
Dimensions (W x L x H; mm)	35 × 167 × 119
Installation	Wall Mounting Installation or DIN-Rail Installation (Optional)
Environmental	
Temperature/ Humidity	Operating Temperature: -25 °C to +75 °C; Storage Temperature: -40 °C to +80 °C; 10 to 90% RH, Non-condensing
Power Requirements	
Input Range/ Consumption	+12 to +48 VDC; 4.8 W

Software Specifications

Function	Description
Operation Interface	<ul style="list-style-type: none"> Web Page
Power data collection	<ul style="list-style-type: none"> Power data collection; Real-time and Historical power data displayed Power data logging and historical power data statistics report provided PUE information provided and displayed
Power demand management	<ul style="list-style-type: none"> Built-in IF-THEN-ELSE logic engine for thought-out power demand management Supports ICP DAS iWSN signal sensing module to collect sensor data in real time Provide schedule timing control function Provide message notification function via Email, Telegram and LINE (PMC-2246M-iWSN also provides WeChat message notification function)
Integrate with SCADA/ IT/IoT/ System	<ul style="list-style-type: none"> Support Modbus TCP/RTU, MQTT, SNMP(v1, v2c), CGI protocols to transmit real-time power data Power data logging and power data file auto send-back (by FTP protocol) & recovery when network is resumed after disconnection Support DDNS (Dynamic DNS) system Support Microsoft Azure, IBM Bluemix IoT Cloud platforms Support ICP DAS IoTstar Cloud software

Appearance

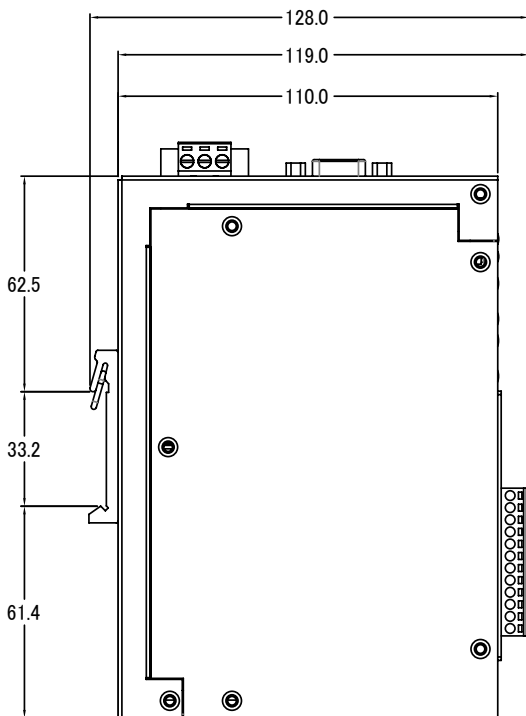
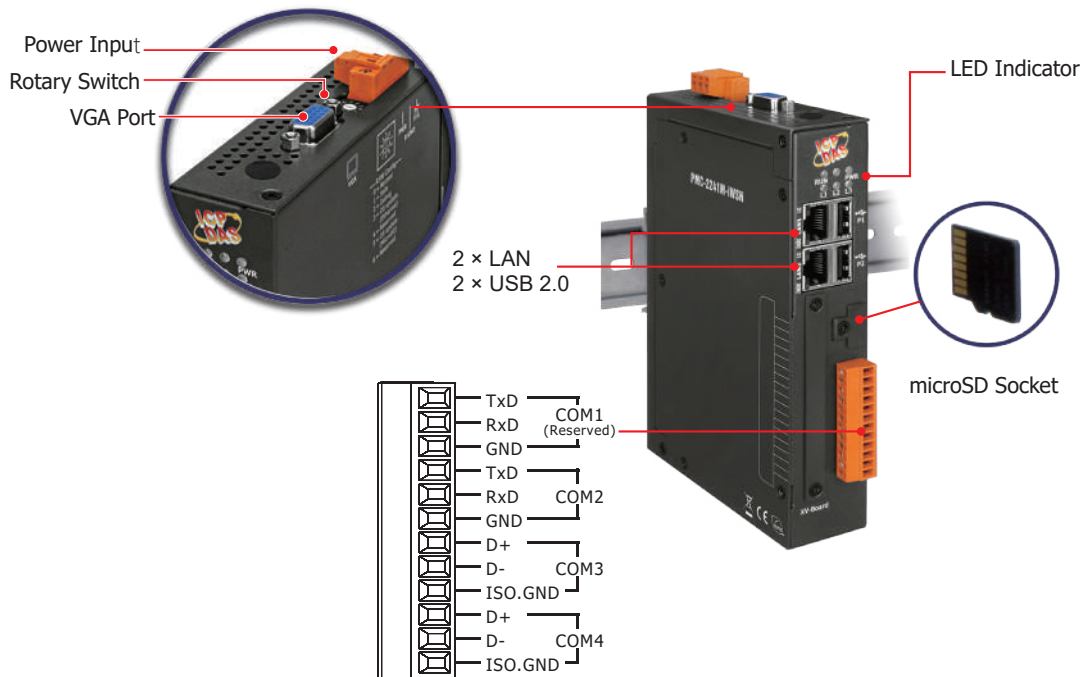

Left Side View

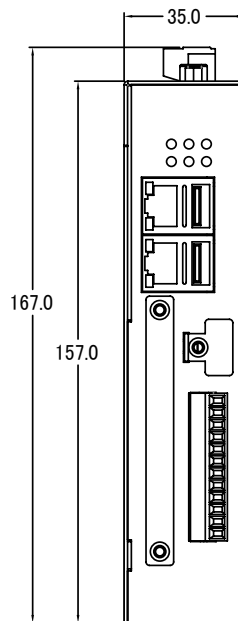

Front View

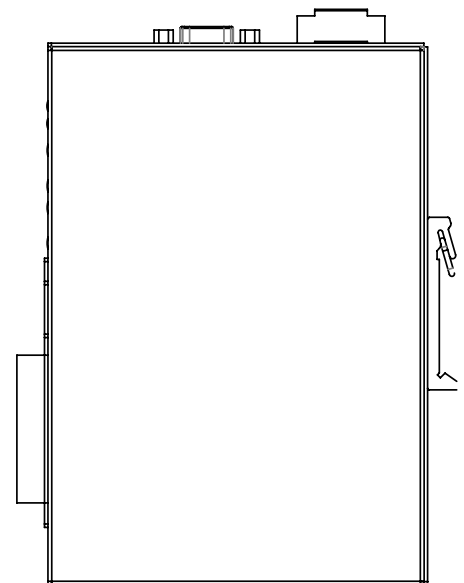

Right Side View

Ordering Information

PMC-2241M-iWSN CR	IIoT iWSN Power Meter Concentrator (Support iWSN wireless power meter and signal sensing module; Metal casing)
PMC-2246M-iWSN CR	IIoT iWSN Power Meter Concentrator (Support iWSN wireless power meter and signal sensing module; Metal casing; Support for WeChat Message Sending)

Ch5. Smart Power Meter

5.1 PM Series Features and Selection Guide

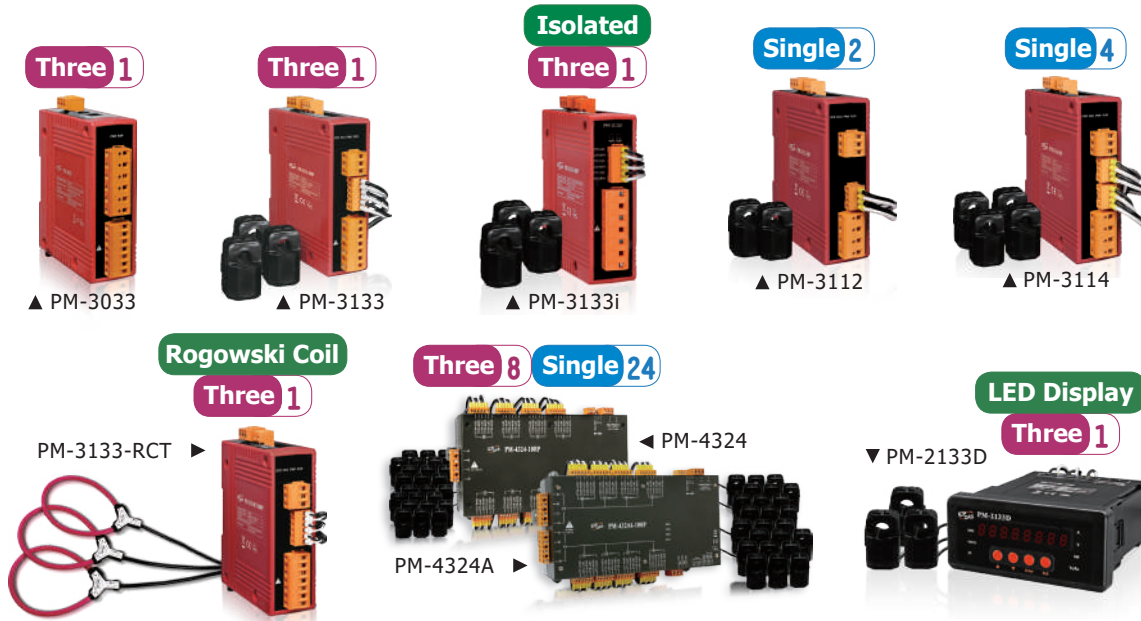

- Support multiple communication interface
 - RS-485 (Modbus RTU)
 - Ethernet (Modbus TCP, EtherNet/IP)
 - CAN bus (CANopen)
- Bi-directional kWh metering function for accurate measurement of power consumption and generation data
- Compact in size and easy to install, suitable for various industrial sites
- Available with CT for accurate metering, accuracy better than 0.5% (PF=1)
- Clip-on CT for easy installation

Selection Guide

Module No.	Phase	Loop	+/- kWh	CT Included	Max. Voltage	Max. Current	Max. CT ID	Cable Length
PM-3112-xxx	Single	2	-	Yes	300 V	200 A	24 mm	1.8 m
PM-3114-xxx		4						4m
PM-3112-xxxP		2						4 m
PM-3114-xxxP		4						
PM-2133D-xxxP	Three	1	Yes	Yes	500 V	400 A	36 mm	4 m
PM-3033	Three	1	Yes	-	500 V	5 A	-	-
PM-3133P	Three	1	Yes	-	500 V	333mV	-	-
PM-3133-xxx	Three	1	Yes	Yes	500 V	400 A	36 mm	1.8 m
PM-3133-xxxP					500 V			4 m
PM-3133i-xxxP (Note 5)					600 V			4 m
PM-3133-RCTxxxP	Three	1	Yes	Yes	500 V	4000 A	185 mm	4 m
PM-4324P	Single/ Three	24/8	Yes	-	500 V	333mV	-	-
PM-4324-xxxP	Single/ Three	24/8 (Note 4)	Yes	Yes	500 V	400 A	36 mm	4 m
PM-4324A-xxxP					500 V			

Note 1: Maximum CT cable length can be extend to **8m**. (except for Rogowski Coil CT), and the accuracy does not decrease.

[We suggest to use twisted pair cable AWG18-14, sectional area from 0.75 ~ 2.0mm².]

Note 2: The end of power meters with -xxx or -xxxP means the specification of the CT. Users can choose the suitable one based on difference of current range and cable section area.

Note 3: The end of power meters with -xxxP, the P means CT has built-in circuit protection to prevent CT from secondary open-circuit danger to human.

Note 4: The PM-4324A has **2 separate main circuit inputs** that can use in the different power system.

Note 5: Built-in AC isolator protection, this means total isolation between the AC measurement side and the control side.

Note 6: [Bi-dir. Energy] stands for [Bi-directional Energy].

CT Dimensions (Units: mm)

005: CTΦ10mm (5 A Max.)
100: CTΦ10mm (60 A Max.)

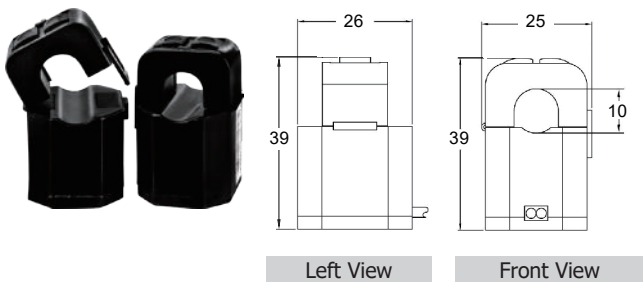

360P: CTΦ36mm (300 A Max.)

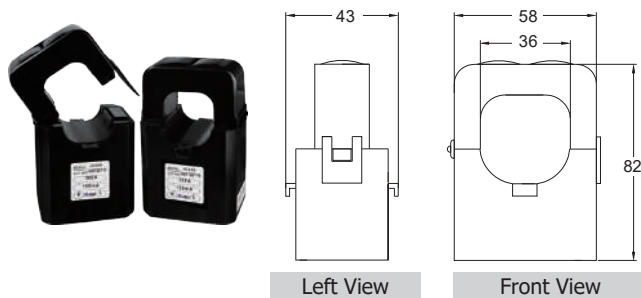

160: CTΦ16mm (100 A Max.)

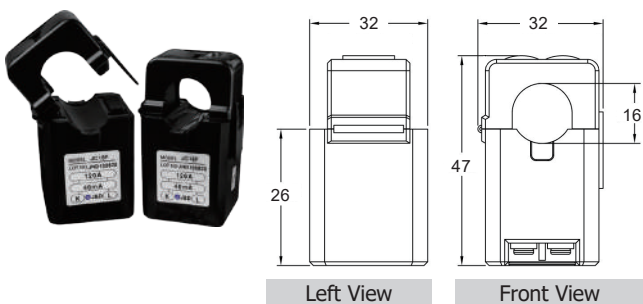

400P: CTΦ36mm (400 A Max.)

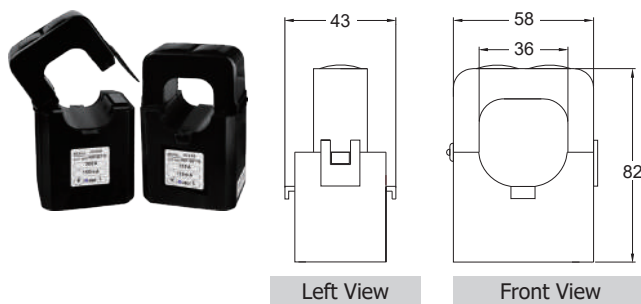

240: CTΦ24mm (200 A Max.)

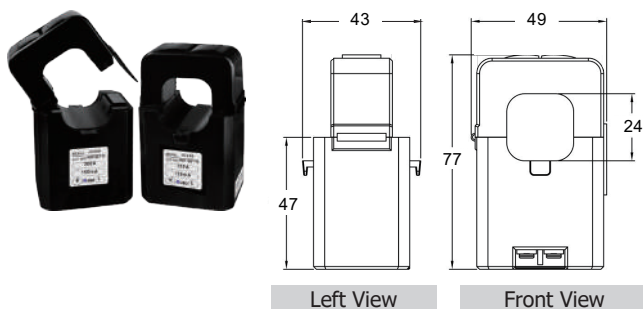

Models	A (Inside diameter)	B (Outer diameter)
PM-3133-RCT500P	55 mm	68 mm
PM-3133-RCT1000P	80 mm	93 mm
PM-3133-RCT2000P	105 mm	118 mm
PM-3133-RCT4000P	185 mm	199 mm



CT Installation Smart Power Meter

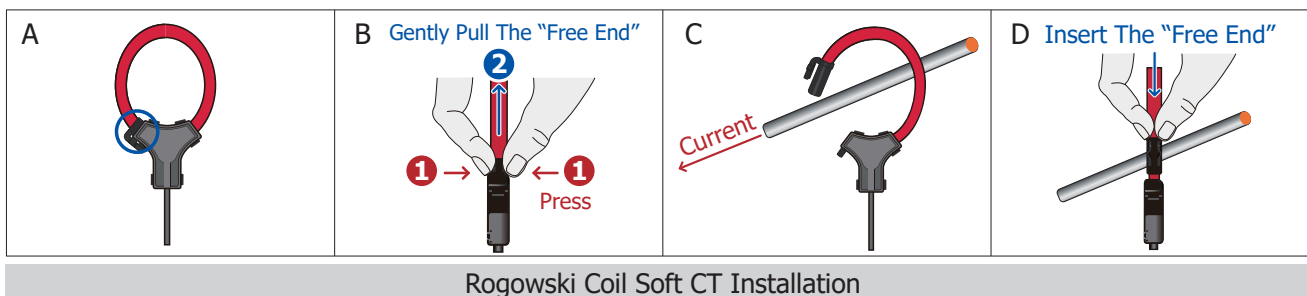
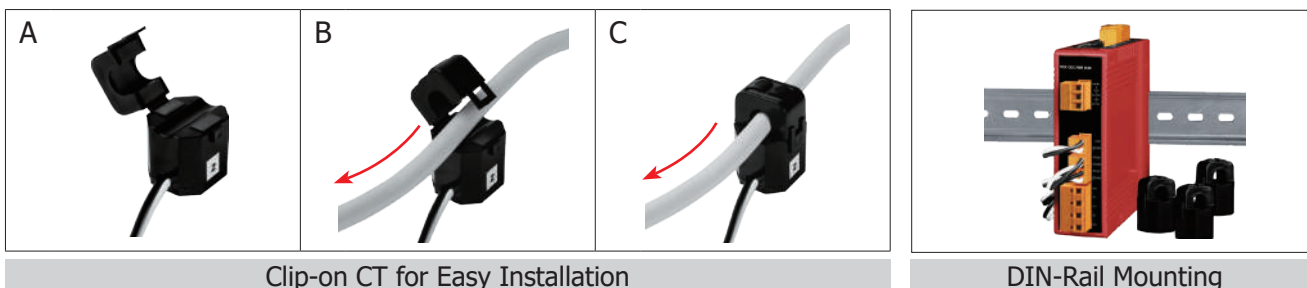

5.2 Smart Power Meter with LED Display



Features

- Bi-directional Energy
- True RMS Power Measurements
- Energy Analysis for 3P4W, 3P3W, 1P3W, 1P2W
- Current Measurements Up to 400 A with Different CT Ratio
- Voltage Measurements Up to 500 V
- Clip-on CT for Easy Installation
- W Accuracy Better than 0.5% (PF=1)
- Total Harmonic Distortion (THD)
- 8 - Digit LED Display
- Supports Modbus RTU Protocol



Introduction

ICP DAS brings the most powerful, cost-effective, advanced Smart Power Meters PM-2133D series that gives you access to real-time electric usage for three-phase power measurement. With its high accuracy (<0.5%, PF=1), the PM-2133D series can be applied to both low voltage primary side and/or medium/high voltage secondary side and enables the users to obtain reliable and accurate energy consumption readings from the monitored equipments in real time under operation. These compact size and cost-effective power meters are equipped with revolutionary wired clip-on CT (various types, support input current up to 400 A). It operates over a wide input voltages range 10 to 500 VAC which allows worldwide compatibility. This meter has LED display shows power.

Specifications

Models		PM-2133D	PM-2133D-MTCP
AC Power Measurement			
Wiring		3P4W-3CT, 3P3W-2CT, 3P3W-3CT, 1P2W-1CT, 1P3W-2CT	
Input Voltage		10 to 500 V	
Input Current		CTØ10 mm (0.05 A to 60 A); CTØ16 mm (0.1 A to 100 A); CTØ24 mm (0.15 A to 200 A); CTØ36 mm (0.3 A to 300 A); CTØ36 mm (0.3 A to 400 A).	
Input Frequency		50 Hz (Range 45 to 55 Hz)/60 Hz (Range 55 to 65 Hz)	
W Accuracy		Better than 0.5% (PF=1)	
Power Parameter Measurement		True RMS voltage (V_{rms}), True RMS current (I_{rms}), Active Power (kW), Active Energy (kWh), Apparent Power (kVA), Apparent Energy (kVAh), Reactive Power (kVAR), Reactive Energy (kVARh), Power Factor (PF), Frequency (45 to 65 Hz)	
Data Update Rate		1 Second	
Display Type		LED display	
Communication			
RS-485	Protocol	Modbus RTU	-
	Baud Rate	9600,19200 (default), 38400, 115200	-
	Data Format	N,8,1(default); N,8,2; E,8,1; E,8,2; O,8,1; O,8,2	-
	Isolation	3000 V _{DC}	-
Ethernet	Protocol	-	Modbus TCP
Power			
Input Range		+85 to +264 V _{AC} (277 V _{AC} available)	
Power Consumption		6 W	
Environment			
Operating Temperature		-20 to +70 °C	
Storage Temperature		-25 to +80 °C	
Ambient Relative Humidity		10% to 90% RH, Non-condensing	

Installation and Wiring

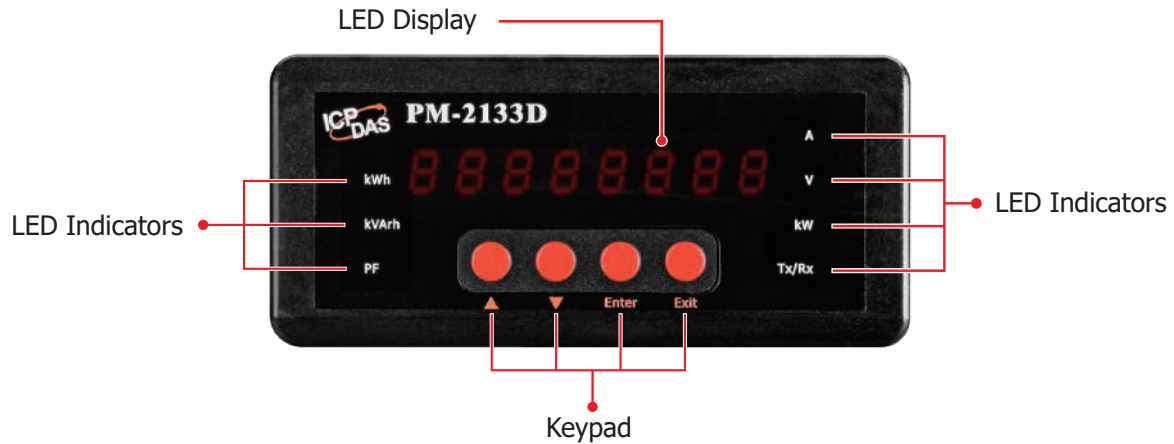

AC Measurement
10 ~ 500 V

External Current Transformers (CTs)

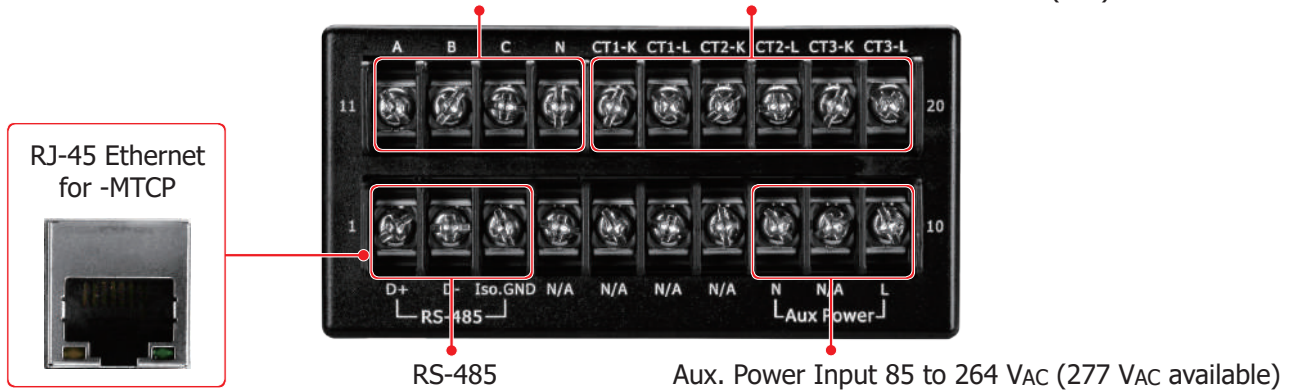

Dimensions (Units: mm)

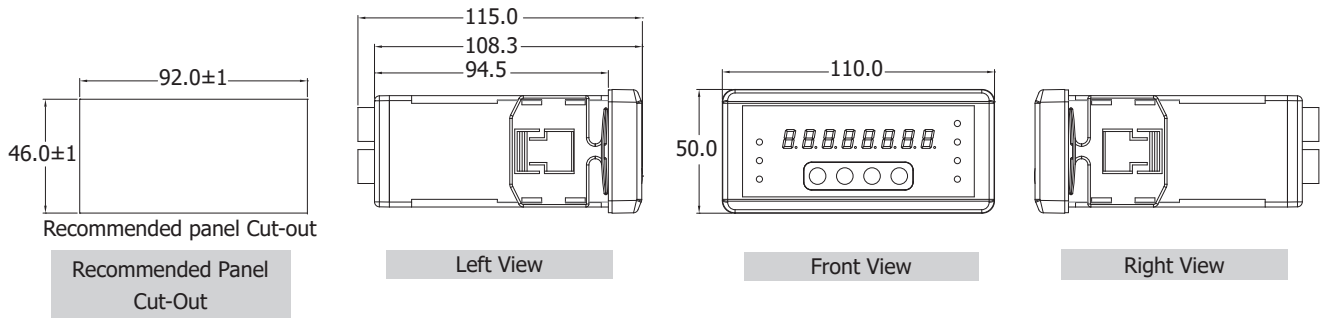

Ordering Information

RS-485 Interface	
PM-2133D-100P CR	Modbus RTU, 3-phase power meter; includes 60A CT (Inside diameter 10 mm; wire lead 4 m) x 3 (RoHS)
PM-2133D-160P CR	Modbus RTU, 3-phase power meter; includes 100A CT (Inside diameter 16 mm; wire lead 4 m) x 3 (RoHS)
PM-2133D-240P CR	Modbus RTU, 3-phase power meter; includes 200A CT (Inside diameter 24 mm; wire lead 4 m) x 3 (RoHS)
PM-2133D-360P CR	Modbus RTU, 3-phase power meter; includes 300A CT (Inside diameter 36 mm; wire lead 4 m) x 3 (RoHS)
PM-2133D-400P CR	Modbus RTU, 3-phase power meter; includes 400A CT (Inside diameter 36 mm; wire lead 4 m) x 3 (RoHS)

Ethernet Interface (Available soon)	
PM-2133D-100P-MTCP CR	Modbus TCP, 3-phase power meter; includes 60A CT (Inside diameter 10 mm; wire lead 4 m) x 3 (RoHS)
PM-2133D-160P-MTCP CR	Modbus TCP, 3-phase power meter; includes 100A CT (Inside diameter 16 mm; wire lead 4 m) x 3 (RoHS)
PM-2133D-240P-MTCP CR	Modbus TCP, 3-phase power meter; includes 200A CT (Inside diameter 24 mm; wire lead 4 m) x 3 (RoHS)
PM-2133D-360P-MTCP CR	Modbus TCP, 3-phase power meter; includes 300A CT (Inside diameter 36 mm; wire lead 4 m) x 3 (RoHS)
PM-2133D-400P-MTCP CR	Modbus TCP, 3-phase power meter; includes 400A CT (Inside diameter 36 mm; wire lead 4 m) x 3 (RoHS)



Features

- Bi-directional Energy
- True RMS Power Measurements
- Energy Analysis for 3P4W, 3P3W, 1P3W, 1P2W
- Current Measurements Up to 400 A with Different CT Ratio
- Isolated Voltage Measurements Up to 600 V
- Clip-on CT for Easy Installation
- W Accuracy Better than 0.5% (PF=1)
- Total Harmonic Distortion (THD)
- RS-485, Ethernet or CAN bus communication interface
- Supports Modbus RTU, Modbus TCP, CANopen or EtherNet/IP Protocols
- IEC 61010-1 and EN 61010-1
- Multiple Data Format



Introduction

ICP DAS brings the most powerful, cost-effective, advanced Smart Power Meters PM-3133i series that gives you access to real-time electric usage for three-phase power measurement. With its high accuracy (<0.5%, PF=1), the PM-3133i series can be applied to both low voltage primary side and/or medium/high voltage secondary side and enables the users to obtain reliable and accurate energy consumption readings from the monitored equipments in real time under operation. These compact size and cost-effective power meters are equipped with revolutionary wired clip-on CT (various types, support input current up to 400 A). It operates over a wide input voltages range 10 to 600 VAC which allows worldwide compatibility. Built-in AC isolator protection, this means total isolation between the AC measurement side and the control side.

Specifications

Models	PM-3133i	PM-3133i-MTCP	PM-3133i-EIP	PM-3133i-CPS
AC Power Measurement				
Wiring	3P4W-3CT, 3P3W-2CT, 3P3W-3CT, 1P2W-1CT, 1P3W-2CT			
Input Voltage	10 to 600 V; built-in isolation transformer			
Input Current	CTØ10 mm (0.05 A to 60 A); CTØ16 mm (0.1 A to 100 A); CTØ24 mm (0.15 A to 200 A); CTØ36 mm (0.3 A to 300 A); CTØ36 mm (0.3 A to 400 A).			
Input Frequency	50 Hz (Range 45 to 55 Hz)/60 Hz (Range 55 to 65 Hz)			
W Accuracy	Better than 0.5% (PF=1)			
Power Parameter Measurement	True RMS voltage (V_{rms}), True RMS current (I_{rms}), Active Power (kW), Active Energy (kWh), Apparent Power (kVA), Apparent Energy (kVAh), Reactive Power (kVAR), Reactive Energy (kVARh), Power Factor (PF), Frequency (45 to 65 Hz)			
Data Update Rate	1 Second			
Communication				
RS-485	Protocol	Modbus RTU	-	-
	Baud Rate	9600,19200 (default), 38400, 115200; DIP Switch Selectable	-	-
	Data Format	N,8,1 (default); N,8,2; E,8,1; E,8,2; O,8,1; O,8,2	-	-
	Isolation	3000 Vdc	-	-
Ethernet	Protocol	-	Modbus TCP	EtherNet/IP
CAN bus	Protocol	-	-	CANopen
	Baud Rate	-	-	125 k (default), 250 k, 500 k, 1 M; DIP Switch Selectable
	Isolation	-	-	3000 VDC
Power				
Input Range	+12 to 48 Vdc	+12 to 48 Vdc	+12 to 48 Vdc	
Power Consumption	2 W			
Environment				
Temperature	Operating Temperature: -20 to +70 °C / Storage Temperature: -25 to +80 °C			
Ambient Relative Humidity	10% to 90% RH, Non-condensing			

Wire Connections

When the inverter is running, it will generate some high frequency or low frequency noise, and interfere with the peripheral equipment by conduction or radiation.

It is recommended that the CT and reference voltage of the meter be installed on the primary side of the "AC Filter" with an EMI ferrite core to minimize the interference effects of the inverter.

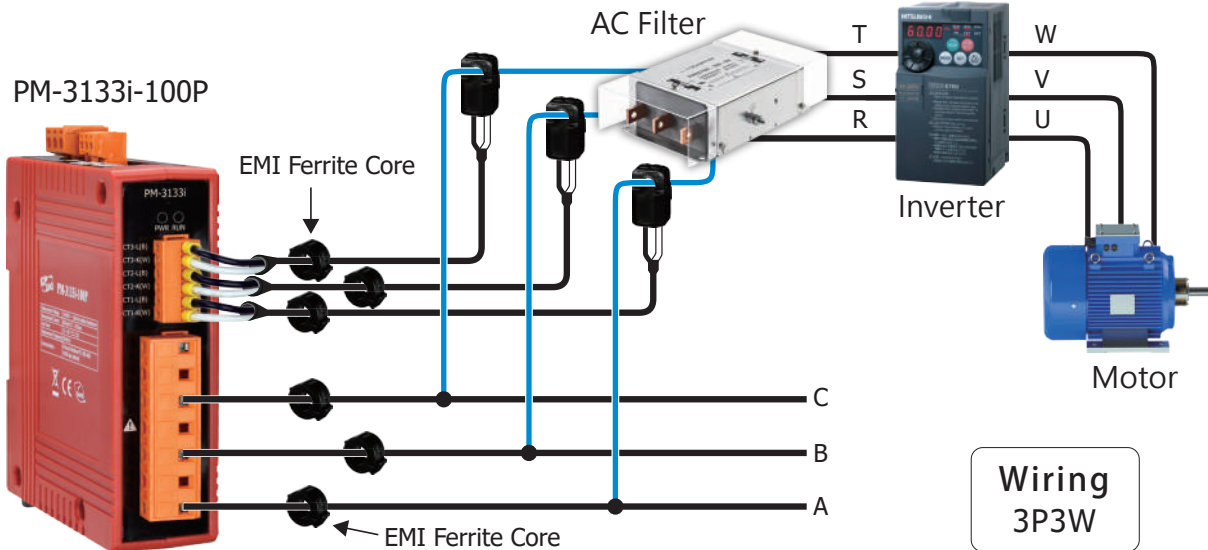

Dimensions (Units: mm)

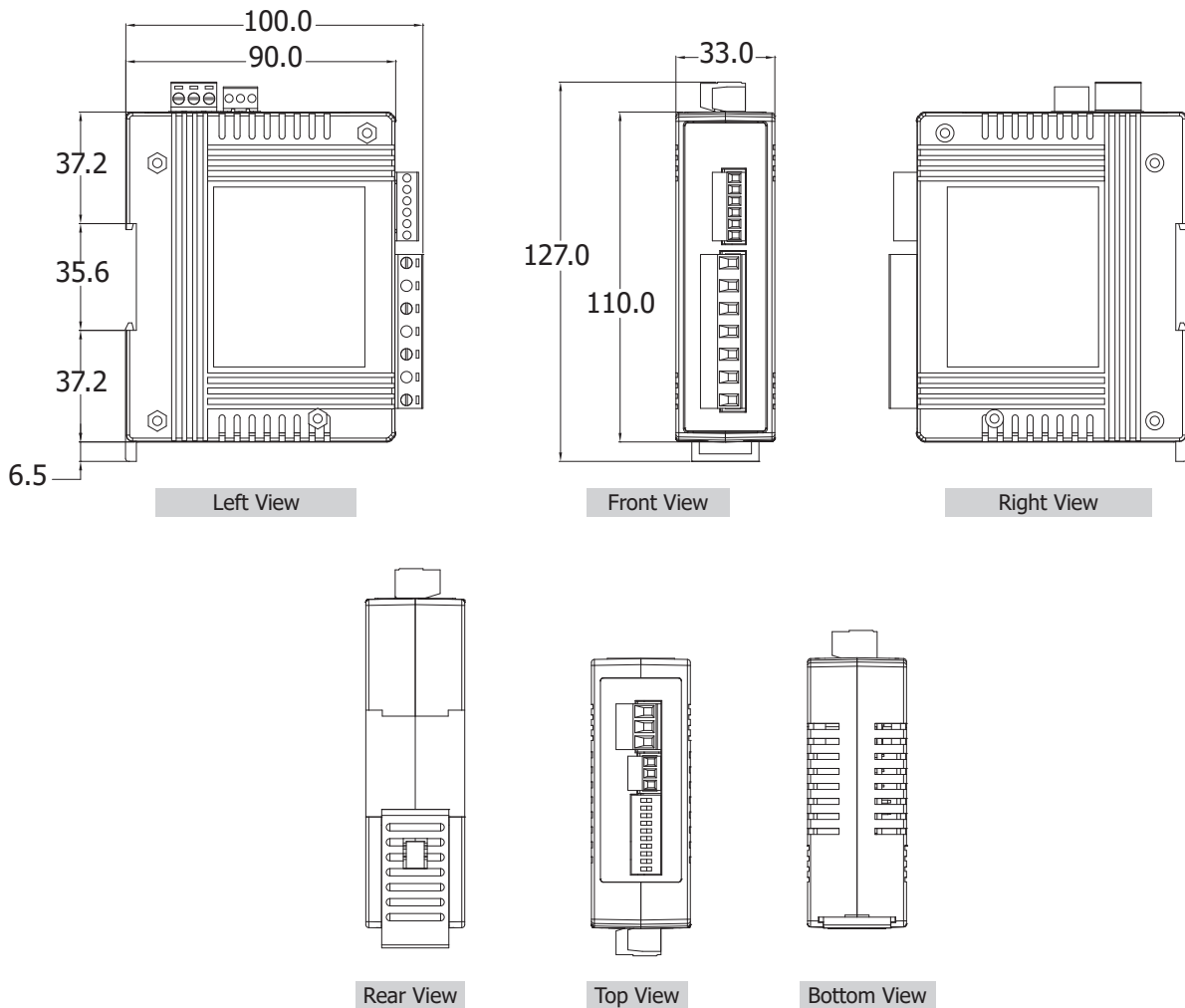

Ordering Information

RS-485 Interface	
PM-3133i-100P CR	Modbus RTU, Isolated 3-phase power meter; includes 60A CT (Inside diameter 10 mm; wire lead 4 m) x 3 (RoHS)
PM-3133i-160P CR	Modbus RTU, Isolated 3-phase power meter; includes 100A CT (Inside diameter 16 mm; wire lead 4 m) x 3 (RoHS)
PM-3133i-240P CR	Modbus RTU, Isolated 3-phase power meter; includes 200A CT (Inside diameter 24 mm; wire lead 4 m) x 3 (RoHS)
PM-3133i-360P CR	Modbus RTU, Isolated 3-phase power meter; includes 300A CT (Inside diameter 36 mm; wire lead 4 m) x 3 (RoHS)
PM-3133i-400P CR	Modbus RTU, Isolated 3-phase power meter; includes 400A CT (Inside diameter 36 mm; wire lead 4 m) x 3 (RoHS)

Ethernet Interface (Modbus TCP)	
PM-3133i-100P-MTCP CR	Modbus TCP, Isolated 3-phase power meter; includes 60A CT (Inside diameter 10 mm; wire lead 4 m) x 3 (RoHS)
PM-3133i-160P-MTCP CR	Modbus TCP, Isolated 3-phase power meter; includes 100A CT (Inside diameter 16 mm; wire lead 4 m) x 3 (RoHS)
PM-3133i-240P-MTCP CR	Modbus TCP, Isolated 3-phase power meter; includes 200A CT (Inside diameter 24 mm; wire lead 4 m) x 3 (RoHS)
PM-3133i-360P-MTCP CR	Modbus TCP, Isolated 3-phase power meter; includes 300A CT (Inside diameter 36 mm; wire lead 4 m) x 3 (RoHS)
PM-3133i-400P-MTCP CR	Modbus TCP, Isolated 3-phase power meter; includes 400A CT (Inside diameter 36 mm; wire lead 4 m) x 3 (RoHS)

Ethernet Interface (EtherNet/IP)	
PM-3133i-100P-EIP CR	EtherNet/IP, Isolated 3-phase power meter; includes 60A CT (Inside diameter 10 mm; wire lead 4 m) x 3 (RoHS)
PM-3133i-160P-EIP CR	EtherNet/IP, Isolated 3-phase power meter; includes 100A CT (Inside diameter 16 mm; wire lead 4 m) x 3 (RoHS)
PM-3133i-240P-EIP CR	EtherNet/IP, Isolated 3-phase power meter; includes 200A CT (Inside diameter 24 mm; wire lead 4 m) x 3 (RoHS)
PM-3133i-360P-EIP CR	EtherNet/IP, Isolated 3-phase power meter; includes 300A CT (Inside diameter 36 mm; wire lead 4 m) x 3 (RoHS)
PM-3133i-400P-EIP CR	EtherNet/IP, Isolated 3-phase power meter; includes 400A CT (Inside diameter 36 mm; wire lead 4 m) x 3 (RoHS)

CAN bus Interface (Available soon)	
PM-3133i-100P-CPS CR	CANopen, Isolated 3-phase power meter; includes 60A CT (Inside diameter 10 mm; wire lead 4 m) x 3 (RoHS)
PM-3133i-160P-CPS CR	CANopen, Isolated 3-phase power meter; includes 100A CT (Inside diameter 16 mm; wire lead 4 m) x 3 (RoHS)
PM-3133i-240P-CPS CR	CANopen, Isolated 3-phase power meter; includes 200A CT (Inside diameter 24 mm; wire lead 4 m) x 3 (RoHS)
PM-3133i-360P-CPS CR	CANopen, Isolated 3-phase power meter; includes 300A CT (Inside diameter 36 mm; wire lead 4 m) x 3 (RoHS)
PM-3133i-400P-CPS CR	CANopen, Isolated 3-phase power meter; includes 400A CT (Inside diameter 36 mm; wire lead 4 m) x 3 (RoHS)



Features

- Bi-directional Energy
- True RMS Power Measurements
- Energy Analysis for 3P4W, 3P3W, 1P3W, 1P2W
- Current Measurements Up to 400 A with Different CT Ratio
- Voltage Measurements Up to 500 V
- Clip-on CT for Easy Installation
- W Accuracy Better than 0.5% (PF=1)
- Total Harmonic Distortion (THD)
- Supports RS-485, Ethernet (PoE) or CANopen Interface
- Supports Modbus RTU, Modbus TCP, CANopen or EtherNet/IP Protocol
- Supports 2 Power Relay Output (Form A)
- IEC 61010-1 and EN 61010-1
- Multiple Data Format



Introduction

ICP DAS brings the most powerful, cost-effective, advanced Smart Power Meters PM-3133 series that gives you access to real-time electric usage for three-phase power measurement. With its high accuracy (<0.5%, PF=1), the PM-3133 series can be applied to both low voltage primary side and/ or medium/high voltage secondary side and enables the users to obtain reliable and accurate energy consumption readings from the monitored equipment in real time under operation. These compact size and cost-effective power meters are equipped with revolutionary wired clip-on CT (various types, support input current up to 400 A). It operates over a wide input voltages range 10 to 500 VAC which allows worldwide compatibility. And with 2 channels relay outputs, it can be linked with sirens or lightings for alarm messages. It also supports Modbus RTU, Modbus TCP, CANopen or EtherNet/IP protocols for easy integration.

Specifications

Models	PM-3133	PM-3133-MTCP	PM-3133-EIP	PM-3133-CPS
AC Power Measurement				
Wiring	3P4W-3CT, 3P3W-2CT, 3P3W-3CT, 1P2W-1CT, 1P3W-2CT			
Measurement Voltage	10 to 500 V			
Measurement Current	-005 (0.05 A to 5 A); -100 (0.05 A to 60 A); -160 (0.1 A to 100 A); -240 (0.15 A to 200 A); -360 (0.3 A to 300 A); -400 (0.3 A to 400 A)			
Measurement Frequency	50/60 Hz			
W Accuracy	Better than 0.5% (PF=1; -005 Input Current >0.5A; -100 Input Current >1.5A; -160 Input Current >3A; -240 Input Current >3.5A; -360 Input Current >7A; -400 Input Current >10A).			
Power Parameter Measurement	True RMS voltage (Vrms), True RMS current (Irms), Active Power (KW), Active Energy (kWh), Apparent Power (kVA), Apparent Energy (kVAh), Reactive Power (kVAR), Reactive Energy (kVARh), Power Factor (PF), Frequency (45 to 65 Hz)			
Data Update Rate	1 Second			
Communication				
RS-485	Protocol	Modbus RTU	-	-
	Baud Rate	9600,19200 (default), 38400, 115200; DIP Switch Selectable	-	-
	Data Format	N,8,1 (default); N,8,2; E,8,1; E,8,2; O,8,1; O,8,2	-	-
	Isolation	3000 VDC	-	-
Ethernet (PoE)	Protocol	-	Modbus TCP EtherNet/IP	-
CANopen	Protocol	-	-	CANopen
	Baud Rate	-	-	125 k (default), 250 k, 500 k, 1 M; DIP Switch Selectable
	Isolation	-	-	3000 VDC
Alarm Output				
Power Relay	Form A (Normal Open) x 2; Relay Contact Voltage Range: 5 A @ 250 VAC (47 to 63Hz), 5 A @ 30 VDC			
Power				
Power Input	+12 to 48 VDC	+12 to 48 VDC or PoE	+12 to 48 VDC	
Power Consumption	2 W			
Environment				
Temperature	Operating Temperature: -20 to +70 °C / Storage Temperature: -25 to +80 °C			
Ambient Relative Humidity	10% to 90% RH, Non-condensing			

Appearance

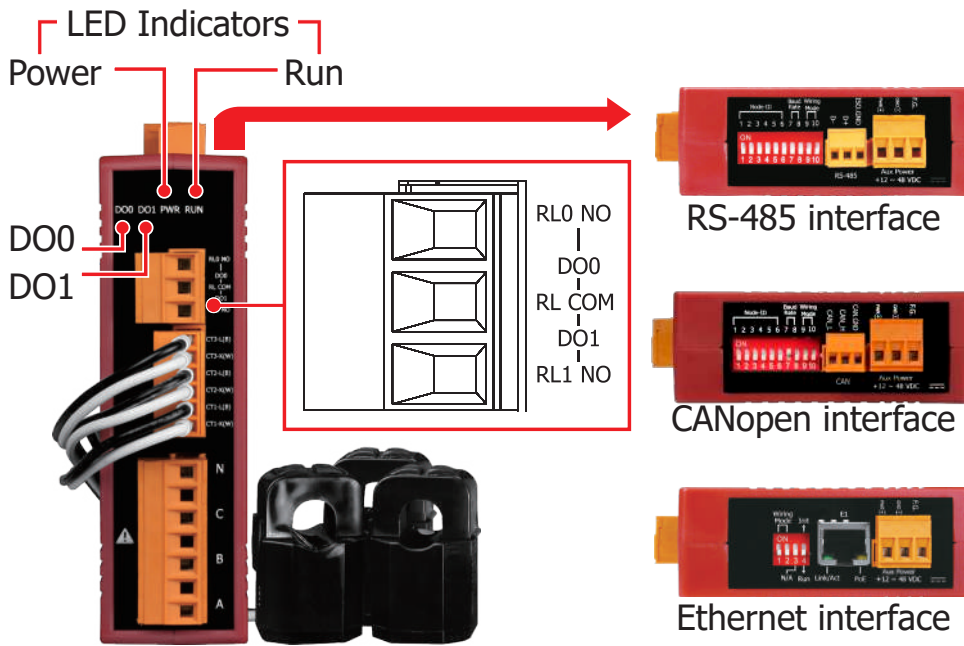

Dimensions (Units: mm)

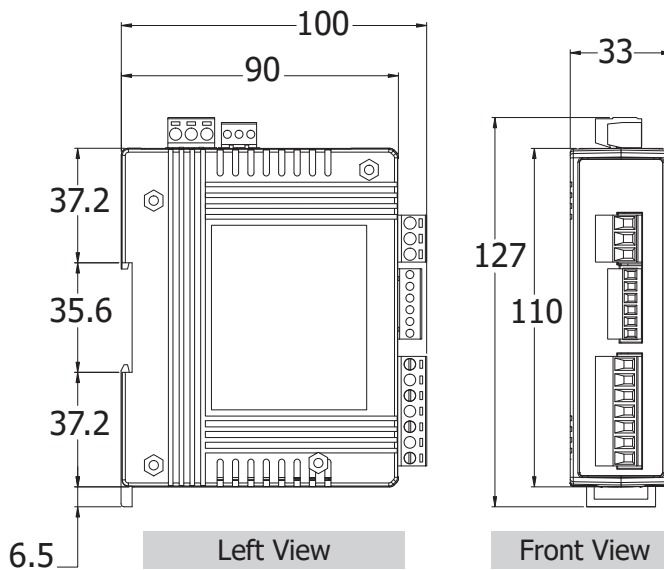

Selection Guide

PM-3133 - [X][X][X]P - [X][X][X]

CT dimensions (Max. Current)
 100: CTΦ10 mm, 60 A Max.
 160: CTΦ16 mm, 100 A Max.
 400: CTΦ36 mm, 400 A Max.
005P: CTΦ10 mm, 5 A Max.
 100P: CTΦ10 mm, 60 A Max.
 160P: CTΦ16 mm, 100 A Max.
 240P: CTΦ24 mm, 200 A Max.
 360P: CTΦ36 mm, 300 A Max.
 400P: CTΦ36 mm, 400 A Max.

Current Transformers
 (Secondary voltage 333 mV)

Communication
 □: RS-485
 CPS: CANopen
 MTCP: Modbus TCP
 EIP: EtherNet/IP

Ordering Information

RS-485 Interface	
PM-3133-100 CR	Modbus RTU, 3-phase power meter; includes 60A CT (Inside diameter 10 mm; wire lead 1.8 m) x 3 (RoHS)
PM-3133-160 CR	Modbus RTU, 3-phase power meter; includes 100A CT (Inside diameter 16 mm; wire lead 1.8 m) x 3 (RoHS)
PM-3133-400-L080 CR	Modbus RTU, 3-phase power meter; includes 400A CT (Inside diameter 36 mm; wire lead 8 m) x 3 (RoHS)
PM-3133-005P CR	Modbus RTU, 3-phase power meter; includes 5A CT (Inside diameter 10 mm; wire lead 4 m) x 3 (RoHS)
PM-3133-100P CR	Modbus RTU, 3-phase power meter; includes 60A CT (Inside diameter 10 mm; wire lead 4 m) x 3 (RoHS)
PM-3133-160P CR	Modbus RTU, 3-phase power meter; includes 100A CT (Inside diameter 16 mm; wire lead 4 m) x 3 (RoHS)
PM-3133-240P CR	Modbus RTU, 3-phase power meter; includes 200A CT (Inside diameter 24 mm; wire lead 4 m) x 3 (RoHS)
PM-3133-360P CR	Modbus RTU, 3-phase power meter; includes 300A CT (Inside diameter 36 mm; wire lead 4 m) x 3 (RoHS)
PM-3133-400P CR	Modbus RTU, 3-phase power meter; includes 400A CT (Inside diameter 36 mm; wire lead 4 m) x 3 (RoHS)

Ethernet Interface (Modbus TCP)	
PM-3133-100-MTCP CR	Modbus TCP, 3-phase power meter; includes 60A CT (Inside diameter 10 mm; wire lead 1.8 m) x 3 (RoHS)
PM-3133-160-MTCP CR	Modbus TCP, 3-phase power meter; includes 100A CT (Inside diameter 16 mm; wire lead 1.8 m) x 3 (RoHS)
PM-3133-005P-MTCP CR	Modbus TCP, 3-phase power meter; includes 5A CT (Inside diameter 10 mm; wire lead 4 m) x 3 (RoHS)
PM-3133-100P-MTCP CR	Modbus TCP, 3-phase power meter; includes 60A CT (Inside diameter 10 mm; wire lead 4 m) x 3 (RoHS)
PM-3133-160P-MTCP CR	Modbus TCP, 3-phase power meter; includes 100A CT (Inside diameter 16 mm; wire lead 4 m) x 3 (RoHS)
PM-3133-240P-MTCP CR	Modbus TCP, 3-phase power meter; includes 200A CT (Inside diameter 24 mm; wire lead 4 m) x 3 (RoHS)
PM-3133-360P-MTCP CR	Modbus TCP, 3-phase power meter; includes 300A CT (Inside diameter 36 mm; wire lead 4 m) x 3 (RoHS)
PM-3133-400P-MTCP CR	Modbus TCP, 3-phase power meter; includes 400A CT (Inside diameter 36 mm; wire lead 4 m) x 3 (RoHS)

Ethernet Interface (EtherNet/IP)	
PM-3133-100-EIP CR	EtherNet/IP, 3-phase power meter; includes 60A CT (Inside diameter 10 mm; wire lead 1.8 m) x 3 (RoHS)
PM-3133-100P-EIP CR	EtherNet/IP, 3-phase power meter; includes 60A CT (Inside diameter 10 mm; wire lead 4 m) x 3 (RoHS)
PM-3133-160P-EIP CR	EtherNet/IP, 3-phase power meter; includes 100A CT (Inside diameter 16 mm; wire lead 4 m) x 3 (RoHS)
PM-3133-240P-EIP CR	EtherNet/IP, 3-phase power meter; includes 200A CT (Inside diameter 24 mm; wire lead 4 m) x 3 (RoHS)
PM-3133-360P-EIP CR	EtherNet/IP, 3-phase power meter; includes 300A CT (Inside diameter 36 mm; wire lead 4 m) x 3 (RoHS)
PM-3133-400P-EIP CR	EtherNet/IP, 3-phase power meter; includes 400A CT (Inside diameter 36 mm; wire lead 4 m) x 3 (RoHS)

CAN bus Interface	
PM-3133-100-CPS CR	CANopen, 3-phase power meter; includes 60A CT (Inside diameter 10 mm; wire lead 1.8 m) x 3 (RoHS)
PM-3133-160-CPS CR	CANopen, 3-phase power meter; includes 100A CT (Inside diameter 16 mm; wire lead 1.8 m) x 3 (RoHS)
PM-3133-005P-CPS CR	CANopen, 3-phase power meter; includes 5A CT (Inside diameter 10 mm; wire lead 4 m) x 3 (RoHS)
PM-3133-240P-CPS CR	CANopen, 3-phase power meter; includes 200A CT (Inside diameter 24 mm; wire lead 4 m) x 3 (RoHS)
PM-3133-360P-CPS CR	CANopen, 3-phase power meter; includes 300A CT (Inside diameter 36 mm; wire lead 4 m) x 3 (RoHS)
PM-3133-400P-CPS CR	CANopen, 3-phase power meter; includes 400A CT (Inside diameter 36 mm; wire lead 4 m) x 3 (RoHS)

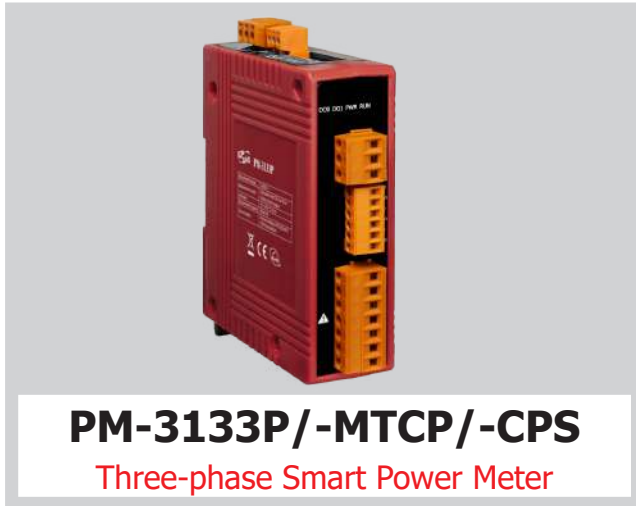

Features

- Bi-directional Energy
- True RMS Power Measurements
- Energy Analysis for 3P4W, 3P3W, 1P3W, 1P2W
- Measure different current ranges with different 333mV CTs; Rogowski coils are not supported
- Voltage Measurements Up to 500 V
- W Accuracy Better than 5% (PF=1)
- Total Harmonic Distortion (THD)
- Supports RS-485, Ethernet (PoE) or CANopen Interface
- Supports Modbus RTU, Modbus TCP or CANopen Protocol
- Supports 2 Power Relay Output (Form A)
- IEC 61010-1 and EN 61010-1
- Multiple Data Format



ICP DAS brings the most powerful, cost-effective, advanced Smart Power Meters PM-3133P series that gives you access to real-time electric usage for three-phase power measurement. With high accuracy (<5%, PF=1), the PM-3133P series can be applied to both low voltage primary side and/or medium/high voltage secondary side and enables the users to obtain reliable and accurate energy consumption readings from the monitored equipments in real time under operation. It operates over a wide input voltages range 10 to 500 VAC which allows worldwide compatibility. And with 2 channels relay outputs, it can be linked with sirens or lightings for alarm messages. It also supports Modbus RTU, Modbus TCP or CANopen protocols for easy integration. You can use CTs (other than Rogowski coils) that you currently own with PM-3133P (without CTs) Power Meter. The CT inputs of the PM-3133P can be directly input from the secondary side of 333mV CT.

Specifications

Models	PM-3133P	PM-3133P-MTCP	PM-3133P-CPS
AC Power Measurement			
Wiring	3P4W-3CT, 3P3W-2CT, 3P3W-3CT, 1P2W-1CT, 1P3W-2CT		
Measurement Voltage	10 to 500 V		
Measurement Current	Measure different current ranges with different 333mV CTs		
Measurement Frequency	50/60 Hz		
W Accuracy	Better than 5% (PF=1)		
Power Parameter Measurement	True RMS voltage (V_{rms}), True RMS current (I_{rms}), Active Power (kW), Active Energy (kWh), Apparent Power (kVA), Apparent Energy (kVAh), Reactive Power (kVAR), Reactive Energy (kVARh), Power Factor (PF), Frequency		
Data Update Rate	1 Second		
Communication			
RS-485	Protocol	Modbus RTU	-
	Baud Rate	9600,19200 (default), 38400, 115200; DIP Switch Selectable	-
	Data Format	N,8,1 (default); N,8,2; E,8,1; E,8,2; O,8,1; O,8,2	-
	Isolation	3000 V _{dc}	-
Ethernet (PoE)	Protocol	-	Modbus TCP
CANopen	Protocol	-	CANopen
	Baud Rate	-	125 k (default), 250 k, 500 k, 1 M; DIP Switch Selectable
	Isolation	-	3000 V _{dc}
Alarm Output			
Power Relay	Form A (Normal Open) x 2; Relay Contact Voltage Range: 5 A @ 250 V _{Ac} (47 to 63Hz), 5 A @ 30 V _{dc}		
Power			
Power Input	+12 to 48 V _{dc}	+12 to 48 V _{dc} or PoE	+12 to 48 V _{dc}
Power Consumption	2 W		
Environment			
Temperature	Operating Temperature: -20 to +70 °C / Storage Temperature: -25 to +80 °C		
Ambient Relative Humidity	10% to 90% RH, Non-condensing		

Appearance

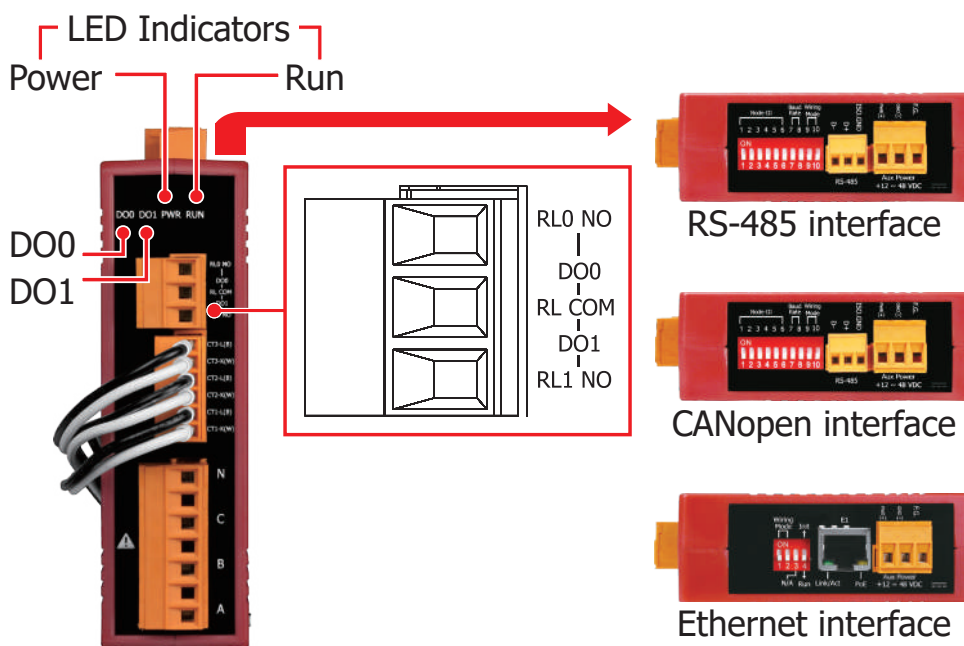

Dimensions (Units: mm)

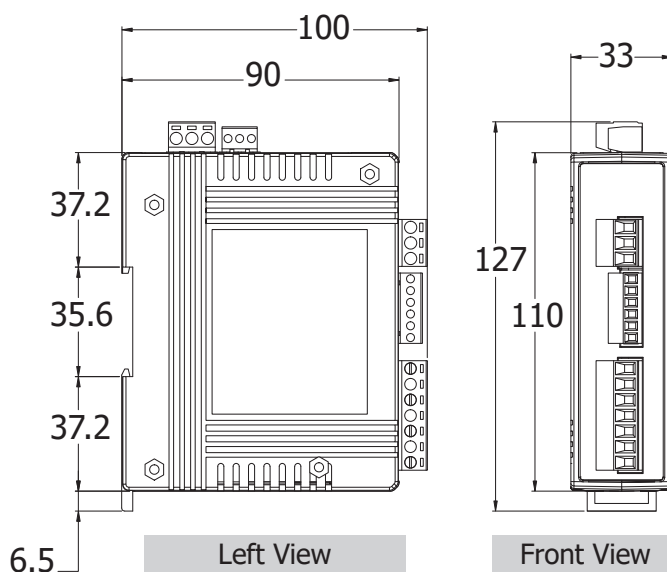

Ordering Information

RS-485 Interface	
PM-3133P CR	Modbus RTU, 3-phase power meter (Can be directly input from the secondary side of 333mV CT; Rogowski coils are not supported) (RoHS)
Ethernet Interface	
PM-3133P-MTCP CR	Modbus TCP, 3-phase power meter (Can be directly input from the secondary side of 333mV CT; Rogowski coils are not supported) (RoHS)
CAN bus Interface	
PM-3133P-CPS CR	CANopen, 3-phase power meter (Can be directly input from the secondary side of 333mV CT; Rogowski coils are not supported) (RoHS)

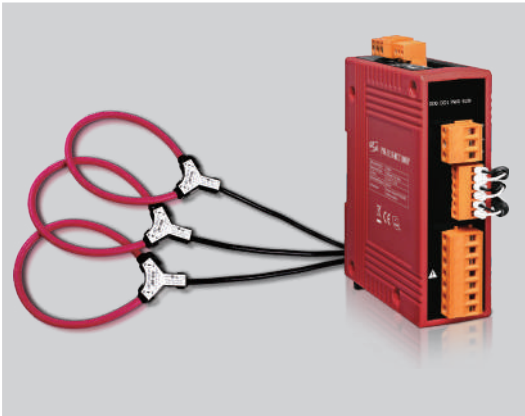

PM-3133-RCT

Three-phase Smart Power Meter

Features

- Bi-directional Energy
- True RMS Power Measurements
- Energy Analysis for 3P4W, 3P3W, 1P3W, 1P2W
- Current Measurements Up to 4000 A
- Voltage Measurements Up to 500 V
- Rogowski Coil Soft CT for Easy Installation
- W Accuracy Better than 2% (PF=1; Input Current >50A; for -500P and -1000P)
W Accuracy Better than 2% (PF=1; Input Current >200A; for -2000P and -4000P)
- Total Harmonic Distortion (THD)
- Supports RS-485, Ethernet (PoE) or CANopen Interface
- Supports Modbus RTU, Modbus TCP, CANopen, or EtherNet/IP Protocol
- Supports 2 Power Relay Output (Form A)
- IEC 61010-1 and EN 61010-1
- Multiple Data Format



ICP DAS has launched the PM-3133-RCT series of smart power meters, offering a powerful and cost-effective solution designed for real-time three-phase power system measurement. This series uses easy-to-install Rogowski coil rope-type current transformers, suitable for high current measurements from 500A to 4000A (but not suitable for precise low current measurements), making them particularly ideal for installations with large conductor diameters and confined spaces. Even in situations where traditional ferromagnetic material transformers cannot measure, the Rogowski coil current sensors provide a convenient measurement solution. The PM-3133-RCT supports a wide voltage range from 10 to 500 VAC, meeting international voltage standards, and features two relay outputs that can be integrated with alarms or lighting control systems to signal anomalies in power measurement information. Additionally, the series supports Modbus RTU, Modbus TCP, CANopen, or EtherNet/IP protocols, facilitating integration with power monitoring systems.

Specifications

Models	PM-3133-RCT	PM-3133-RCT-MTCP	PM-3133-RCT-EIP	PM-3133-RCT-CPS
AC Power Measurement				
Wiring	3P4W-3CT, 3P3W-2CT, 3P3W-3CT, 1P2W-1CT, 1P3W-2CT			
Measurement Voltage	10 to 500 V			
Measurement Current	CTØ55 mm (5 A to 500 A), CTØ80 mm (5 A to 1000 A), CTØ105 mm (5 A to 2000 A), CTØ185 mm (5 A to 4000 A)			
Measurement Frequency	50/60 Hz			
W Accuracy	Better than 2% (PF=1)			
Power Parameter Measurement	True RMS voltage (V_{rms}), True RMS current (I_{rms}), Active Power (kW), Active Energy (kWh), Apparent Power (kVA), Apparent Energy (kVAh), Reactive Power (kVAR), Reactive Energy (kVARh), Power Factor (PF)			
Data Update Rate	1 Second			
Communication				
Interface	RS-485	Ethernet (PoE)		CANopen
Protocol	Modbus-RTU	Modbus TCP	EtherNet/IP	CANopen
Baud Rate	9600,19200 (default), 38400, 115200; DIP Switch Selectable	-		125 k (default), 250 k, 500 k, 1 M; DIP Switch Selectable
Data Format	N,8,1 (default); N,8,2; E,8,1; E,8,2; O,8,1; O,8,2	-		-
Isolation	3000 V _{dc}	-		3000 V _{dc}
Alarm Output				
Power Relay	Form A (Normal Open) × 2; Relay Contact Voltage Range: 5 A @ 250 V _{ac} (47 to 63Hz), 5 A @ 30 V _{dc}			
Power				
Power Input	+12 to 48 V _{dc}	+12 to 48 V _{dc} or PoE		+12 to 48 V _{dc}
Power Consumption	2 W			
Environment				
Temperature	Operating Temperature: -20 to +70 °C / Storage Temperature: -25 to +80 °C			
Ambient Relative Humidity	10% to 90% RH, Non-condensing			

Installation

Rogowski Coil
Flexible Current Transformers

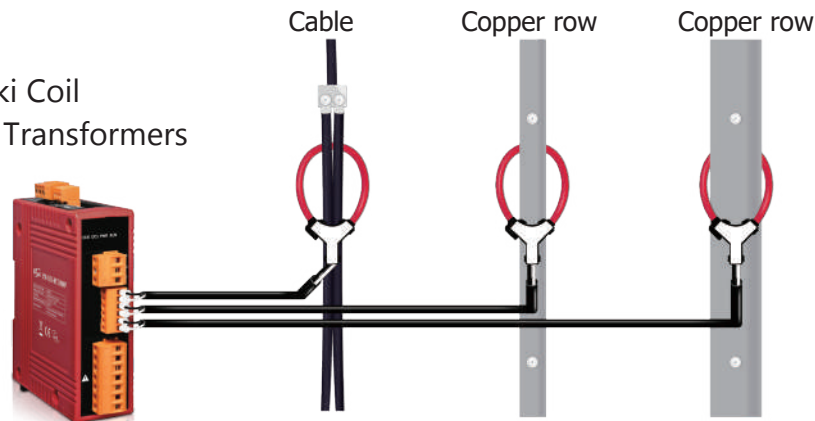

Rogowski Coil CT is "ropestyle" which delivers "Easy Installation" features for large window size and mechanical flexibility for tight space.

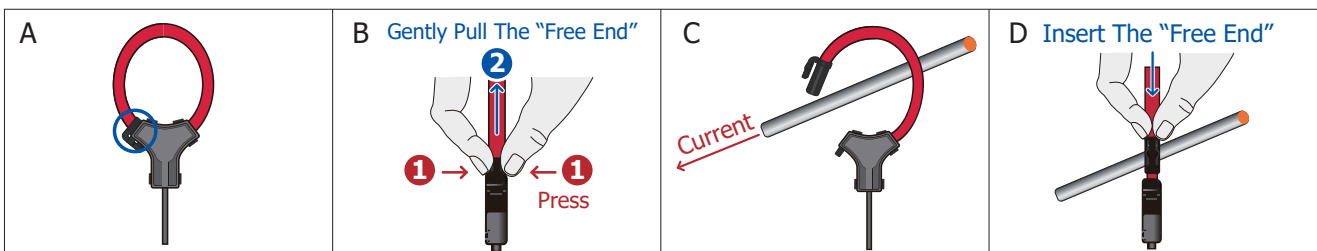

Rogowski Coil Soft CT Installation

Dimensions (Units: mm)

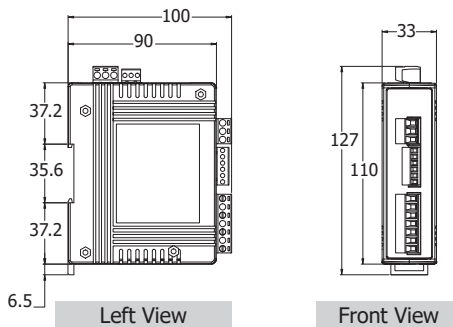

CT Dimensions (Units: mm)

Models	A (Inside diameter)	B (Outer diameter)
PM-3133-RCT500P	55 mm	68 mm
PM-3133-RCT1000P	80 mm	93 mm
PM-3133-RCT2000P	105 mm	118 mm
PM-3133-RCT4000P	185 mm	199 mm

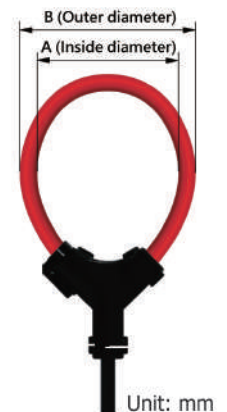

Ordering Information

RS-485 Interface (Modbus RTU)	
PM-3133-RCT500P CR	Modbus RTU, 3-phase power meter, 500A Rogowski Coil CT (Inside diameter 55 mm; wire lead 4 m) x 3 (RoHS)
PM-3133-RCT1000P CR	Modbus RTU, 3-phase power meter, 1000A Rogowski Coil CT (Inside diameter 80 mm; wire lead 4 m) x 3 (RoHS)
PM-3133-RCT2000P CR	Modbus RTU, 3-phase power meter, 2000A Rogowski Coil CT (Inside diameter 105 mm; wire lead 4 m) x 3 (RoHS)
PM-3133-RCT4000P CR	Modbus RTU, 3-phase power meter, 4000A Rogowski Coil CT (Inside diameter 185 mm; wire lead 4 m) x 3 (RoHS)

Ethernet Interface (Modbus TCP)	
PM-3133-RCT500P-MTCP CR	Modbus TCP, 3-phase power meter, 500A Rogowski Coil CT (Inside diameter 55 mm; wire lead 4 m) x 3 (RoHS)
PM-3133-RCT1000P-MTCP CR	Modbus TCP, 3-phase power meter, 1000A Rogowski Coil CT (Inside diameter 80 mm; wire lead 4 m) x 3 (RoHS)
PM-3133-RCT2000P-MTCP CR	Modbus TCP, 3-phase power meter, 2000A Rogowski Coil CT (Inside diameter 105 mm; wire lead 4 m) x 3 (RoHS)
PM-3133-RCT4000P-MTCP CR	Modbus TCP, 3-phase power meter, 4000A Rogowski Coil CT (Inside diameter 185 mm; wire lead 4 m) x 3 (RoHS)

Ethernet Interface (EtherNet/IP)	
PM-3133-RCT500P-EIP CR	EtherNet/IP, 3-phase power meter, 500A Rogowski Coil CT (Inside diameter 55 mm; wire lead 4 m) x 3 (RoHS)
PM-3133-RCT1000P-EIP CR	EtherNet/IP, 3-phase power meter, 1000A Rogowski Coil CT (Inside diameter 80 mm; wire lead 4 m) x 3 (RoHS)
PM-3133-RCT2000P-EIP CR	EtherNet/IP, 3-phase power meter, 2000A Rogowski Coil CT (Inside diameter 105 mm; wire lead 4 m) x 3 (RoHS)
PM-3133-RCT4000P-EIP CR	EtherNet/IP, 3-phase power meter, 4000A Rogowski Coil CT (Inside diameter 185 mm; wire lead 4 m) x 3 (RoHS)

CAN bus Interface (CANopen)	
PM-3133-RCT500P-CPS CR	CANopen, 3-phase power meter, 500A Rogowski Coil CT (Inside diameter 55 mm; wire lead 4 m) x 3 (RoHS)
PM-3133-RCT1000P-CPS CR	CANopen, 3-phase power meter, 1000A Rogowski Coil CT (Inside diameter 80 mm; wire lead 4 m) x 3 (RoHS)
PM-3133-RCT2000P-CPS CR	CANopen, 3-phase power meter, 2000A Rogowski Coil CT (Inside diameter 105 mm; wire lead 4 m) x 3 (RoHS)
PM-3133-RCT4000P-CPS CR	CANopen, 3-phase power meter, 4000A Rogowski Coil CT (Inside diameter 185 mm; wire lead 4 m) x 3 (RoHS)



Features

- Bi-directional Energy
- True RMS Power Measurements
- Energy Analysis for 3P4W, 3P3W, 1P3W, 1P2W
- Direct input of secondary side 1A/5A CT
- Voltage Measurements Up to 500 V
- W Accuracy Better than 0.5% (PF=1)
- Total Harmonic Distortion (THD)
- Supports RS-485, Ethernet (PoE) or CANopen Interface
- Supports Modbus RTU/Modbus TCP or CANopen Protocol
- IEC 61010-1 and EN 61010-1



ICP DAS brings the most powerful, cost-effective, advanced Smart Power Meters PM-3033 series that gives you access to real-time electric usage for three-phase power measurement. With its high accuracy (<0.5%, PF=1), the PM-3033 series can be applied to both low voltage primary side and/or medium/high voltage secondary side and enables the users to obtain reliable and accurate energy consumption readings from the monitored equipments in real time under operation. Direct input from "secondary side 1A/5A" type CTs. Dedicated CTs are no longer needed, which lowers the cost of implementation. It operates over a wide input voltages range 10 to 500 Vac which allows worldwide compatibility. It also supports Modbus RTU, Modbus TCP or CANopen protocols for easy integration.

Specifications

Models	PM-3033	PM-3033-MTCP	PM-3033-CPS
AC Power Measurement			
Wiring	3P4W-3CT, 3P3W-2CT, 3P3W-3CT, 1P2W-1CT, 1P3W-2CT		
Measurement Voltage	10 to 500 V		
Measurement Current	1A or 5A		
Measurement Frequency	50/60 Hz		
W Accuracy	Better than 0.5% (PF=1)		
Power Parameter Measurement	True RMS voltage (V_{rms}), True RMS current (I_{rms}), Active Power (kW), Active Energy (kWh), Apparent Power (kVA), Apparent Energy (kVAh), Reactive Power (kVAR), Reactive Energy (kVARh), Power Factor (PF), Frequency		
Data Update Rate	1 Second		
Communication			
RS-485	Protocol	Modbus RTU	-
	Baud Rate	9600, 19200 (default), 38400, 115200; DIP Switch Selectable	-
	Data Format	N,8,1 (default); N,8,2; E,8,1; E,8,2; O,8,1; O,8,2	-
	Isolation	3000 V _{DC}	-
Ethernet (PoE)	Protocol	-	Modbus TCP
CANopen	Protocol	-	CANopen
	Baud Rate	-	125 k (default), 250 k, 500 k, 1 M; DIP Switch Selectable
	Isolation	-	3000 V _{DC}
Power			
Power Input	+12 to 48 V _{DC}	+12 to 48 V _{DC} or PoE	+12 to 48 V _{DC}
Power Consumption	2 W		
Environment			
Temperature	Operating Temperature: -20 to +70 °C / Storage Temperature: -25 to +80 °C		
Ambient Relative Humidity	10% to 90% RH, Non-condensing		

CT Installation and Wiring

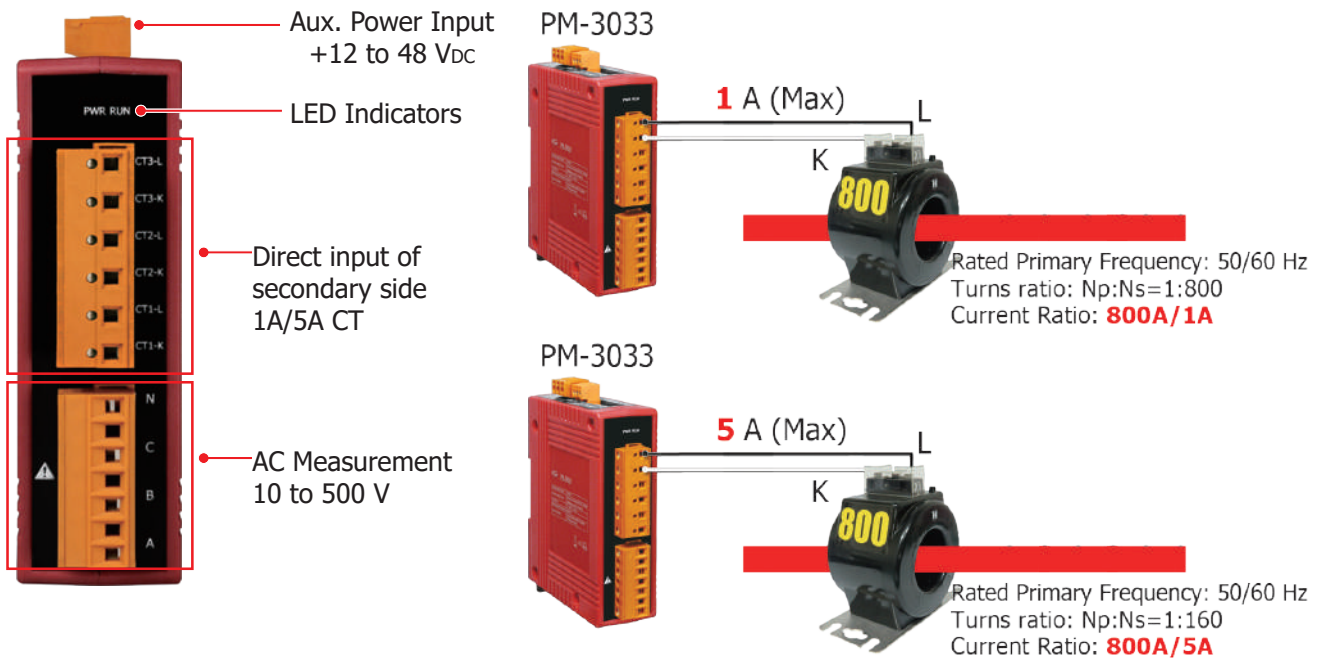

Dimensions (Units: mm)

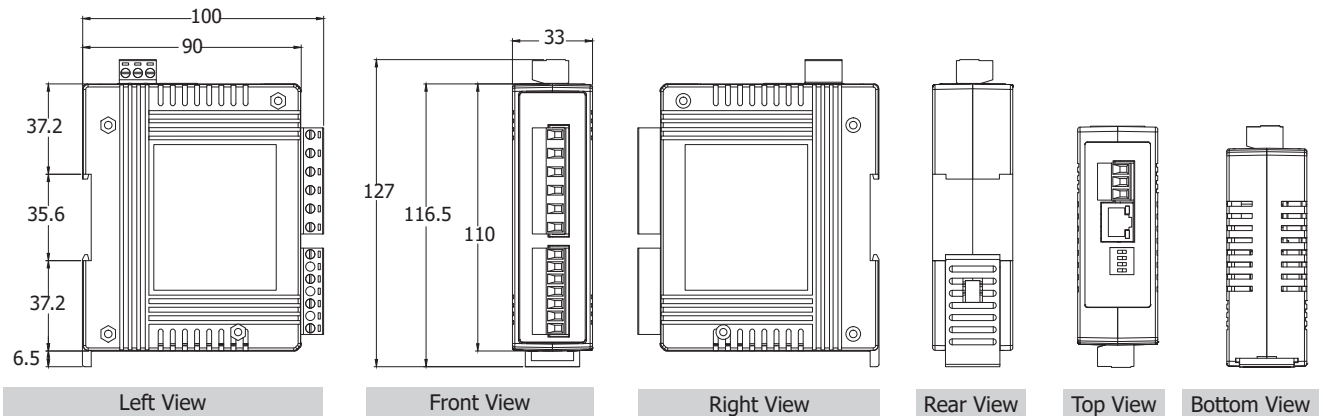

Selection Guide

PM-3033 - X X X

Communication
 RS-485
 CPS: CANopen
 MTCP: Modbus TCP

Ordering Information

RS-485 Interface	
PM-3033 CR	Modbus RTU, 3-phase power meter (1A/5A CT Input type) (RoHS)
Ethernet Interface	
PM-3033-MTCP CR	Modbus TCP, 3-phase power meter (1A/5A CT Input type) (RoHS)
CAN bus Interface	
PM-3033-CPS CR	CANopen, 3-phase power meter (1A/5A CT Input type) (RoHS)

5.4 Single-phase Smart Power Meter

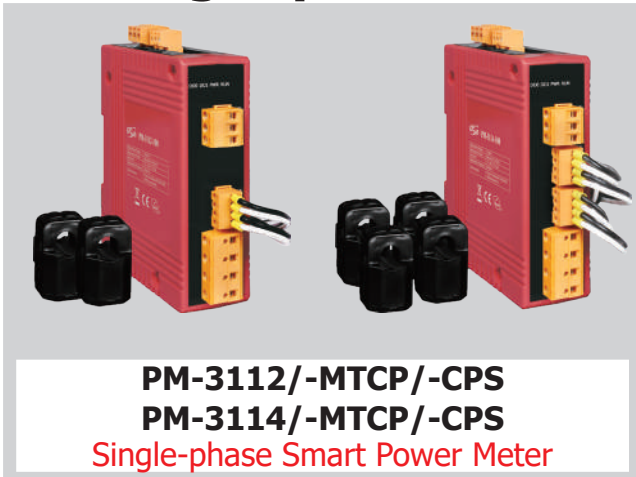

PM-3112/-MTCP/-CPS
PM-3114/-MTCP/-CPS
 Single-phase Smart Power Meter

Features

- True RMS Power Measurements
- Energy Analysis for 1P2W
- Current Measurements Up to 200 A with Different CT Ratio
- Voltage Measurements Up to 300 V
- Clip-on CT for Easy Installation
- W Accuracy Better than 0.5% (PF=1)
- Supports Modbus RTU, Modbus TCP or CANopen Protocol
- Supports 2 Power Relay Output (Form A)
- IEC 61010-1 and EN 61010-1



Introduction

ICP DAS brings the most powerful, cost-effective, advanced Smart Power Meters PM-3000 series that gives you access to real-time electric usage for single-phase power measurement. With its high accuracy ($< 0.5\%$, $PF=1$), the PM-3000 series can be applied to both low voltage primary side and/or medium/high voltage secondary side and enables the users to obtain reliable and accurate energy consumption readings from the monitored equipments in real time under operation. These compact size and cost-effective power meters are equipped with revolutionary wired clip-on CT (various types, support input current up to 200 A). It operates over a wide input voltages range 10 to 300 VAC which allows worldwide compatibility. And with 2 channels relay outputs, it can be linked with sirens or lightings for alarm messages. It also supports Modbus RTU, Modbus TCP or CANopen protocols for easy integration.

Specifications

Models		PM-3112	PM-3114	PM-3112-MTCP	PM-3114-MTCP	PM-3112-CPS	PM-3114-CPS
AC Power Measurement							
Wiring		1P2W-2CT	1P2W-4CT	1P2W-2CT	1P2W-4CT	1P2W-2CT	1P2W-4CT
Input Voltage		10 to 300 V					
Input Current		CTØ10 mm (60 A); CTØ16 mm (100 A); CTØ24 mm (200 A)					
Input Frequency		50/60 Hz					
W Accuracy		Better than 0.5% (PF=1)					
Starting Current		$>0.03A$ (60A), $>0.05A$ (100A), $>0.09A$ (200A)					
Power Parameter Measurement		True RMS voltage (V_{rms}), True RMS current (I_{rms}), Active Power (kW), Active Energy (kWh), Apparent Power (kVA), Apparent Energy (kVAh), Reactive Power (kVAR), Reactive Energy (kVARh), Power Factor (PF), Frequency					
Data Update Rate		1 Second					
Communication							
RS-485	Protocol	Modbus-RTU	-	-	-	-	-
	Baud Rate	9600,19200 (default), 38400, 115200; DIP Switch Selectable	-	-	-	-	-
	Data Format	N,8,1 (default); N,8,2; E,8,1; E,8,2; O,8,1; O,8,2	-	-	-	-	-
	Isolation	3000 V _{DC}	-	-	-	-	-
Ethernet	Protocol	-	Modbus TCP	-	-	-	-
CANopen	Protocol	-	-	-	-	CANopen	-
	Baud Rate	-	-	-	-	125 k (default), 250 k, 500 k, 1 M; DIP Switch Selectable	-
Alarm Output							
Power Relay		Form A (Normal Open) x 2; Relay Contact Voltage Range: 5 A @ 250 V _{AC} (47 to 63Hz), 5 A @ 30 V _{DC}					
Power							
Input Range/Power Consumption		+12 to 48 V _{DC} /2 W					
Environment							
Temperature/Ambient Relative Humidity		Operating Temperature: -20 to +70 °C/Storage Temperature: -25 to +80 °C/10% to 90% RH, Non-condensing					

2 Independent Main Circuit Inputs

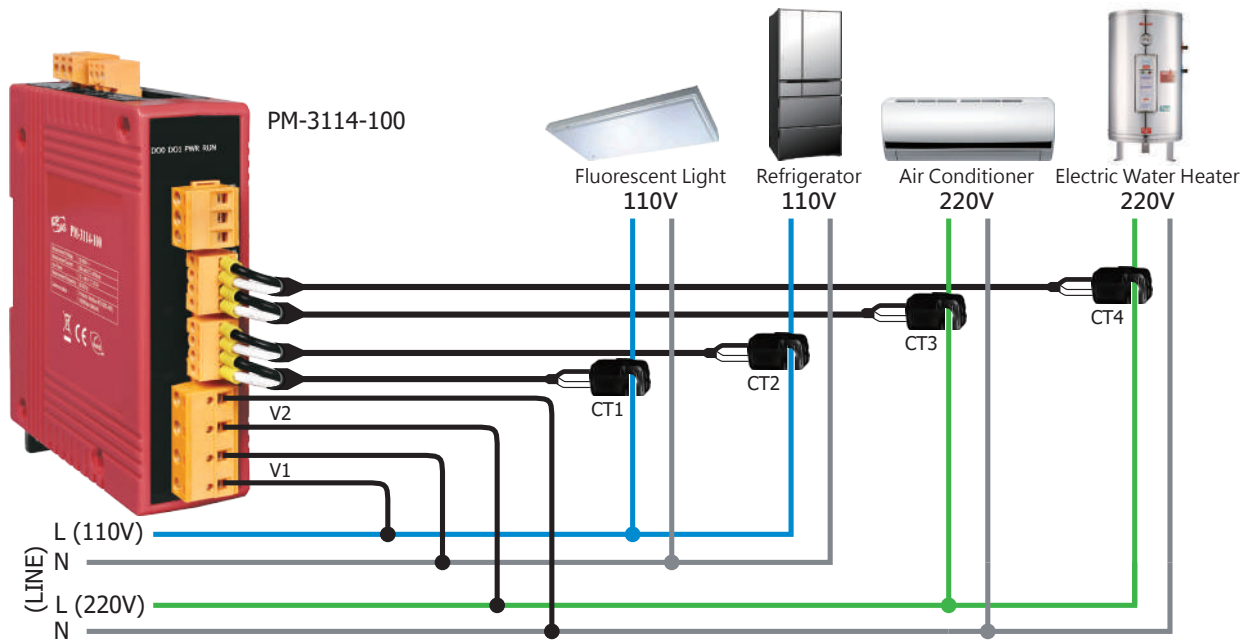

CT1 and CT2 for reference voltage V1; CT3 ~ CT4 for reference voltage V2.

Dimensions (Units: mm)

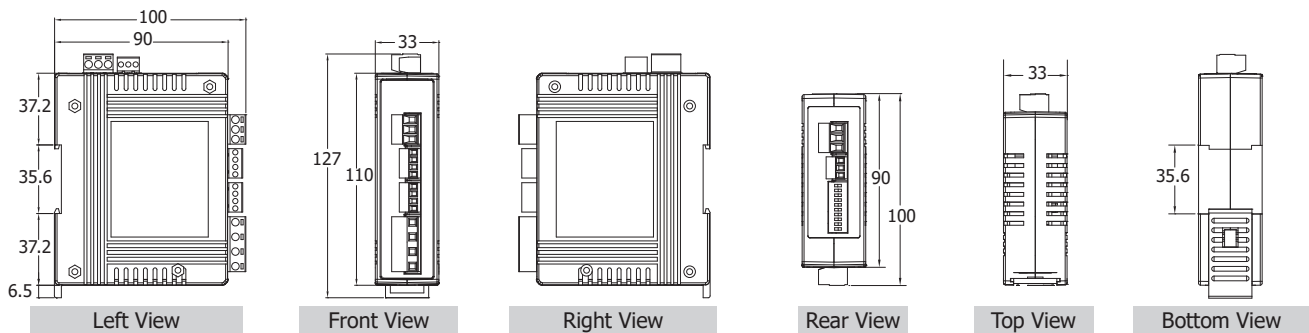

Ordering Information

RS-485 Interface	
PM-3112-100 CR	Modbus RTU, 2 loops single-phase Power Meter; includes 60A CT (Inside diameter 10 mm; wire lead 1.8 m) x 2 (RoHS)
PM-3112-160 CR	Modbus RTU, 2 loops single-phase Power Meter; includes 100A CT (Inside diameter 16 mm; wire lead 1.8 m) x 2 (RoHS)
PM-3112-240P CR	Modbus RTU, 2 loops single-phase Power Meter; includes 200A CT (Inside diameter 24 mm; wire lead 4 m) x 2 (RoHS)
PM-3114-100 CR	Modbus RTU, 4 loops single-phase Power Meter; includes 60A CT (Inside diameter 10 mm; wire lead 1.8 m) x 4 (RoHS)
PM-3114-160 CR	Modbus RTU, 4 loops single-phase Power Meter; includes 100A CT (Inside diameter 16 mm; wire lead 1.8 m) x 4 (RoHS)
PM-3114-240P CR	Modbus RTU, 4 loops single-phase Power Meter; includes 200A CT (Inside diameter 24 mm; wire lead 4 m) x 4 (RoHS)
Ethernet Interface	
PM-3112-100-MTCP CR	Modbus RTU, 2 loops single-phase Power Meter; includes 60A CT (Inside diameter 10 mm; wire lead 1.8 m) x 2 (RoHS)
PM-3112-160-MTCP CR	Modbus RTU, 2 loops single-phase Power Meter; includes 100A CT (Inside diameter 16 mm; wire lead 1.8 m) x 2 (RoHS)
PM-3112-240P-MTCP CR	Modbus RTU, 2 loops single-phase Power Meter; includes 200A CT (Inside diameter 24 mm; wire lead 4 m) x 2 (RoHS)
PM-3114-100-MTCP CR	Modbus RTU, 4 loops single-phase Power Meter; includes 60A CT (Inside diameter 10 mm; wire lead 1.8 m) x 4 (RoHS)
PM-3114-160-MTCP CR	Modbus RTU, 4 loops single-phase Power Meter; includes 100A CT (Inside diameter 16 mm; wire lead 1.8 m) x 4 (RoHS)
PM-3114-240P-MTCP CR	Modbus RTU, 4 loops single-phase Power Meter; includes 200A CT (Inside diameter 24 mm; wire lead 4 m) x 4 (RoHS)
CAN bus Interface	
PM-3112-100-CPS CR	Modbus RTU, 2 loops single-phase Power Meter; includes 60A CT (Inside diameter 10 mm; wire lead 1.8 m) x 2 (RoHS)
PM-3112-160-CPS CR	Modbus RTU, 2 loops single-phase Power Meter; includes 100A CT (Inside diameter 16 mm; wire lead 1.8 m) x 2 (RoHS)
PM-3112-240P-CPS CR	Modbus RTU, 2 loops single-phase Power Meter; includes 200A CT (Inside diameter 24 mm; wire lead 4 m) x 2 (RoHS)
PM-3114-100-CPS CR	Modbus RTU, 4 loops single-phase Power Meter; includes 60A CT (Inside diameter 10 mm; wire lead 1.8 m) x 4 (RoHS)
PM-3114-160-CPS CR	Modbus RTU, 4 loops single-phase Power Meter; includes 100A CT (Inside diameter 16 mm; wire lead 1.8 m) x 4 (RoHS)
PM-3114-240P-CPS CR	Modbus RTU, 4 loops single-phase Power Meter; includes 200A CT (Inside diameter 24 mm; wire lead 4 m) x 4 (RoHS)

5.5 Multi-circuit Smart Power Meter

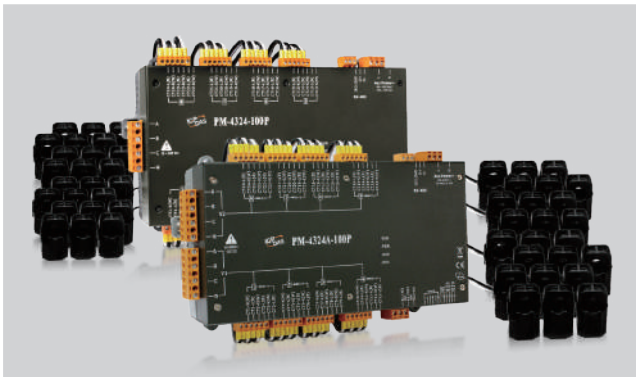

PM-4324/-MTCP/-CPS/EIP
PM-4324A/-MTCP/-CPS/EIP
 Multi-circuit Smart Power Meter

Features

- Bi-directional Energy
- 8 Three Phase Circuits or 24 Single Phase Circuits
- True RMS Power Measurements
- Energy Analysis for 3P4W, 3P3W, 1P3W, 1P2W
- 2 Independent main circuit inputs for PM-4324A series
- Current Measurements Up to 400 A with Different CT Ratio
- Voltage Measurements Up to 500 V
- Easy install with split core CT
- W Accuracy Better than 0.5% (PF=1)
- Total Harmonic Distortion (THD)
- Support RS-485, Ethernet, CAN bus or EtherNet/IP Interface
- Support 2 Power Relay Output (Form A)



Introduction

The PM-4324 series multi-circuit power meter monitors up to 8 three-phase circuits or 24 single-phase circuits, or any combination of single or three-phase circuits. The PM-4324 series can measure up to 24 currents via external Current Transformers (CTs). This flexibility makes the PM-4324 series perfect for multi-tenant facilities such as residential projects, office buildings and shopping malls. This compact instrument is designed to easily fit into existing panelboards or be flush mounted nearby, thus eliminating the need for expensive retrofit projects or for allocating extra space for the device. The PM-4324A is the same model as the PM-4324, except for the AC Measurement. The PM-4324A has 2 separate main circuit inputs that can use in the different power system.

Specifications

Models	PM-4324/PM-4324A	PM-4324-MTCP/ PM-4324A-MTCP	PM-4324-EIP/ PM-4324A-EIP	PM-4324-CPS/PM-4324A-CPS
AC Power Measurement				
Wiring	3P4W-3CT, 3P3W-2CT, 3P3W-3CT, 1P2W-1CT, 1P3W-2CT			
Measurement Voltage	10 to 500 V			
Measurement Current	CTØ10 mm (60 A); CTØ16 mm (100 A); CTØ24 mm (200 A); CTØ36 mm (300 A); CTØ36 mm (400 A)			
Measurement Frequency	50/60 Hz			
W Accuracy	Better than 0.5% (PF=1)			
Power Parameter Measurement	True RMS voltage (V_{rms}), True RMS current (I_{rms}), Active Power (kW), Active Energy (kWh), Apparent Power (kVA), Apparent Energy (kVAh), Reactive Power (kVAR), Reactive Energy (kVARh), Power Factor (PF), Frequency			
Data Update Rate	1 Second			
Communication				
Interface	RS-485	Ethernet		CAN Bus
Protocol	Modbus-RTU	Modbus TCP	EtherNet/IP	CANopen
Baud Rate	9600, 19200 (default), 38400, 115200; DIP Switch Selectable	-		125 k (default), 250 k, 500 k, 1 M; DIP Switch Selectable
Data Format	N,8,1(default); N,8,2; E,8,1; E,8,2; O,8,1; O,8,2	-		-
Isolation	3000 V _{dc}	-		3000 V _{dc}
Alarm Output				
Power Relay	Form A (Normal Open) x 2; Relay Contact Voltage Range: 5 A @ 250 V _{AC} (47 to 63 Hz), 5 A @ 30 V _{DC}			
Power				
Input Range	+85 to +264 V _{AC}			
Power Consumption	6 W			
Mechanical				
Dimensions / Casing	237 mm x 52 mm x 134 mm (W x L x H) / Plastic			
Module Installation	DIN-Rail Mounting			
Environment				
Temperature	Operating Temperature: -20 to +70°C / Storage Temperature: -25 to +80°C			
Ambient Relative Humidity	10% to 90% RH, Non-condensing			

Wire Connections

Dual Main Circuit 3P4W + 1P2W

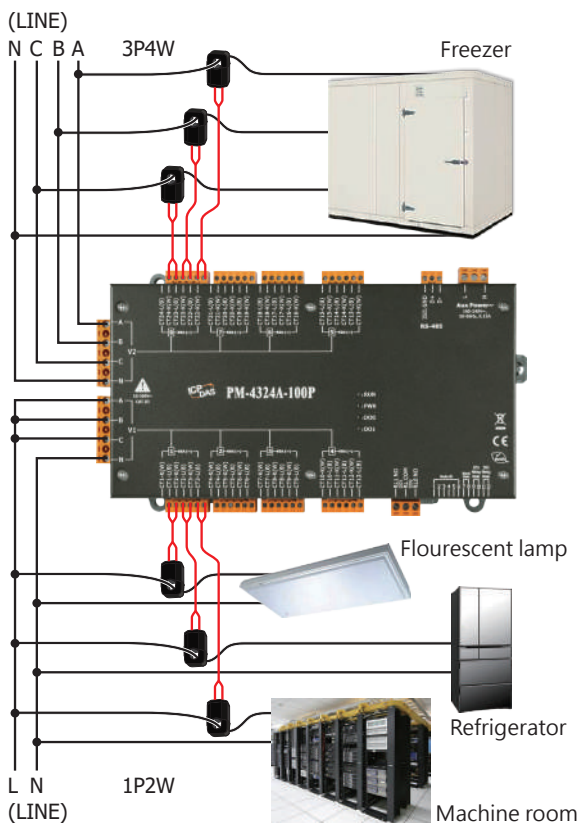

Single Main Circuit 3P3W

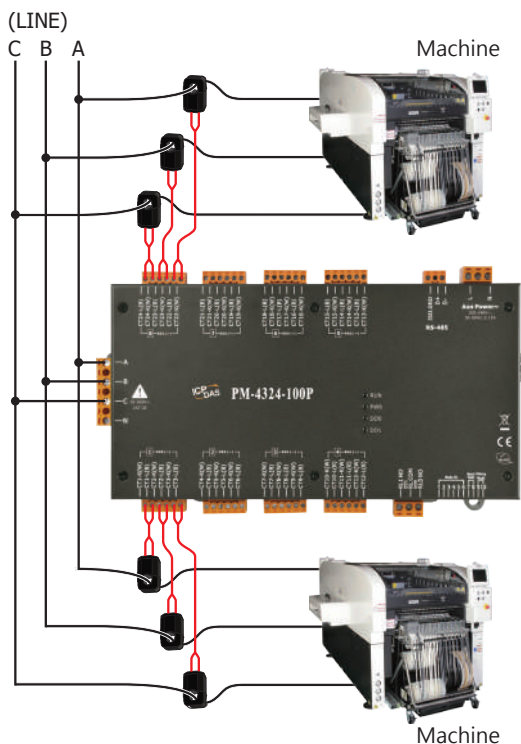

Appearance

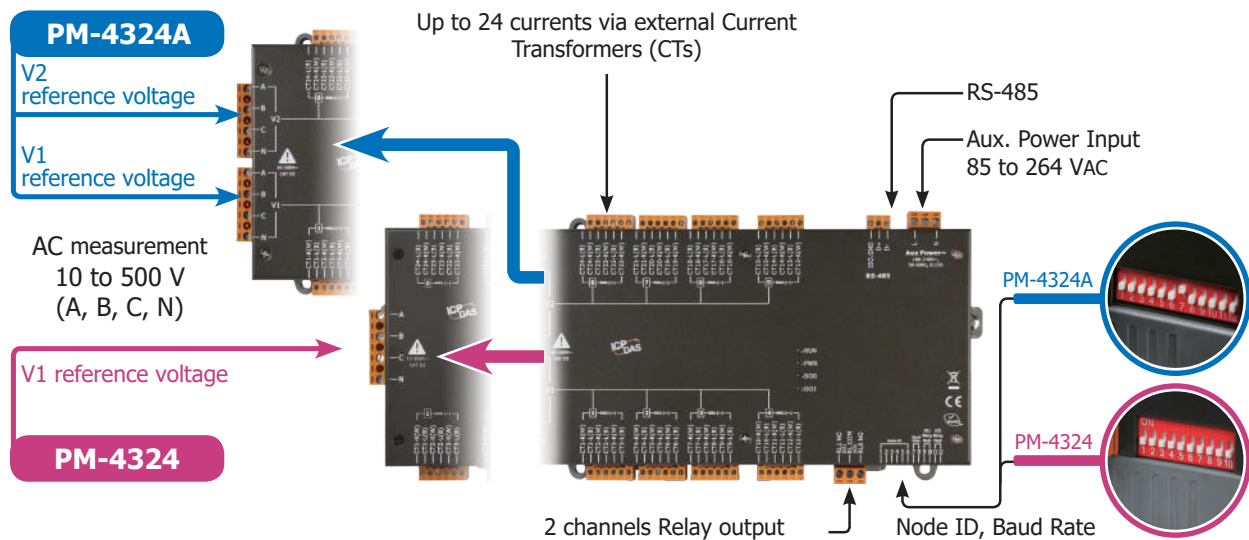

Selection Guide

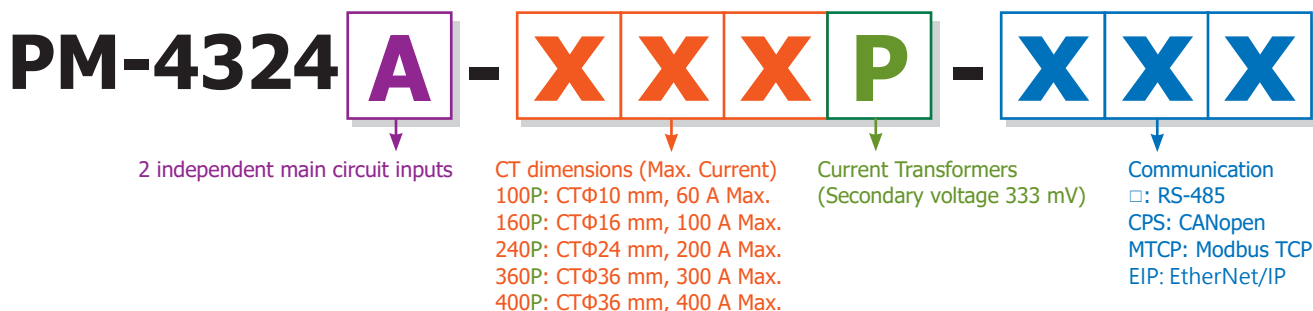

Ordering Information

RS-485 Interface	
PM-4324-100P CR	Modbus RTU, Multi-Circuit Power Meter; includes 60A CT (Inside diameter 10 mm; wire lead 4 m) x 24 (RoHS)
PM-4324-160P CR	Modbus RTU, Multi-Circuit Power Meter; includes 100A CT (Inside diameter 16 mm; wire lead 4 m) x 24 (RoHS)
PM-4324-240P CR	Modbus RTU, Multi-Circuit Power Meter; includes 200A CT (Inside diameter 24 mm; wire lead 4 m) x 24 (RoHS)
PM-4324-360P CR	Modbus RTU, Multi-Circuit Power Meter; includes 300A CT (Inside diameter 36 mm; wire lead 4 m) x 24 (RoHS)
PM-4324-400P CR	Modbus RTU, Multi-Circuit Power Meter; includes 400A CT (Inside diameter 36 mm; wire lead 4 m) x 24 (RoHS)
PM-4324A-100P CR	Modbus RTU, Multi-Circuit Power Meter; includes 60A CT (Inside diameter 10 mm; wire lead 4 m) x 24 (RoHS)
PM-4324A-160P CR	Modbus RTU, Multi-Circuit Power Meter; includes 100A CT (Inside diameter 16 mm; wire lead 4 m) x 24 (RoHS)
PM-4324A-240P CR	Modbus RTU, Multi-Circuit Power Meter; includes 200A CT (Inside diameter 24 mm; wire lead 4 m) x 24 (RoHS)
PM-4324A-360P CR	Modbus RTU, Multi-Circuit Power Meter; includes 300A CT (Inside diameter 36 mm; wire lead 4 m) x 24 (RoHS)
PM-4324A-400P CR	Modbus RTU, Multi-Circuit Power Meter; includes 400A CT (Inside diameter 36 mm; wire lead 4 m) x 24 (RoHS)

Ethernet Interface (Modbus TCP)	
PM-4324-100P-MTCP CR	Modbus TCP, Multi-Circuit Power Meter; includes 60A CT (Inside diameter 10 mm; wire lead 4 m) x 24 (RoHS)
PM-4324-160P-MTCP CR	Modbus TCP, Multi-Circuit Power Meter; includes 100A CT (Inside diameter 16 mm; wire lead 4 m) x 24 (RoHS)
PM-4324-240P-MTCP CR	Modbus TCP, Multi-Circuit Power Meter; includes 200A CT (Inside diameter 24 mm; wire lead 4 m) x 24 (RoHS)
PM-4324-360P-MTCP CR	Modbus TCP, Multi-Circuit Power Meter; includes 300A CT (Inside diameter 36 mm; wire lead 4 m) x 24 (RoHS)
PM-4324-400P-MTCP CR	Modbus TCP, Multi-Circuit Power Meter; includes 400A CT (Inside diameter 36 mm; wire lead 4 m) x 24 (RoHS)
PM-4324A-100P-MTCP CR	Modbus TCP, Multi-Circuit Power Meter; includes 60A CT (Inside diameter 10 mm; wire lead 4 m) x 24 (RoHS)
PM-4324A-160P-MTCP CR	Modbus TCP, Multi-Circuit Power Meter; includes 100A CT (Inside diameter 16 mm; wire lead 4 m) x 24 (RoHS)
PM-4324A-240P-MTCP CR	Modbus TCP, Multi-Circuit Power Meter; includes 200A CT (Inside diameter 24 mm; wire lead 4 m) x 24 (RoHS)
PM-4324A-360P-MTCP CR	Modbus TCP, Multi-Circuit Power Meter; includes 300A CT (Inside diameter 36 mm; wire lead 4 m) x 24 (RoHS)
PM-4324A-400P-MTCP CR	Modbus TCP, Multi-Circuit Power Meter; includes 400A CT (Inside diameter 36 mm; wire lead 4 m) x 24 (RoHS)

Ethernet Interface (EtherNet/IP)	
PM-4324-100P-EIP CR	EtherNet/IP, Multi-Circuit Power Meter; includes 60A CT (Inside diameter 10 mm; wire lead 4 m) x 24 (RoHS)
PM-4324-160P-EIP CR	EtherNet/IP, Multi-Circuit Power Meter; includes 100A CT (Inside diameter 16 mm; wire lead 4 m) x 24 (RoHS)
PM-4324-240P-EIP CR	EtherNet/IP, Multi-Circuit Power Meter; includes 200A CT (Inside diameter 24 mm; wire lead 4 m) x 24 (RoHS)
PM-4324-360P-EIP CR	EtherNet/IP, Multi-Circuit Power Meter; includes 300A CT (Inside diameter 36 mm; wire lead 4 m) x 24 (RoHS)
PM-4324-400P-EIP CR	EtherNet/IP, Multi-Circuit Power Meter; includes 400A CT (Inside diameter 36 mm; wire lead 4 m) x 24 (RoHS)
PM-4324A-100P-EIP CR	EtherNet/IP, Multi-Circuit Power Meter; includes 60A CT (Inside diameter 10 mm; wire lead 4 m) x 24 (RoHS)
PM-4324A-160P-EIP CR	EtherNet/IP, Multi-Circuit Power Meter; includes 100A CT (Inside diameter 16 mm; wire lead 4 m) x 24 (RoHS)
PM-4324A-240P-EIP CR	EtherNet/IP, Multi-Circuit Power Meter; includes 200A CT (Inside diameter 24 mm; wire lead 4 m) x 24 (RoHS)
PM-4324A-360P-EIP CR	EtherNet/IP, Multi-Circuit Power Meter; includes 300A CT (Inside diameter 36 mm; wire lead 4 m) x 24 (RoHS)
PM-4324A-400P-EIP CR	EtherNet/IP, Multi-Circuit Power Meter; includes 400A CT (Inside diameter 36 mm; wire lead 4 m) x 24 (RoHS)

CAN bus Interface	
PM-4324-100P-CPS CR	CANopen, Multi-Circuit Power Meter; includes 60A CT (Inside diameter 10 mm; wire lead 4 m) x 24 (RoHS)
PM-4324-160P-CPS CR	CANopen, Multi-Circuit Power Meter; includes 100A CT (Inside diameter 16 mm; wire lead 4 m) x 24 (RoHS)
PM-4324-240P-CPS CR	CANopen, Multi-Circuit Power Meter; includes 200A CT (Inside diameter 24 mm; wire lead 4 m) x 24 (RoHS)
PM-4324-360P-CPS CR	CANopen, Multi-Circuit Power Meter; includes 300A CT (Inside diameter 36 mm; wire lead 4 m) x 24 (RoHS)
PM-4324-400P-CPS CR	CANopen, Multi-Circuit Power Meter; includes 400A CT (Inside diameter 36 mm; wire lead 4 m) x 24 (RoHS)
PM-4324A-100P-CPS CR	CANopen, Multi-Circuit Power Meter; includes 60A CT (Inside diameter 10 mm; wire lead 4 m) x 24 (RoHS)
PM-4324A-160P-CPS CR	CANopen, Multi-Circuit Power Meter; includes 100A CT (Inside diameter 16 mm; wire lead 4 m) x 24 (RoHS)
PM-4324A-240P-CPS CR	CANopen, Multi-Circuit Power Meter; includes 200A CT (Inside diameter 24 mm; wire lead 4 m) x 24 (RoHS)
PM-4324A-360P-CPS CR	CANopen, Multi-Circuit Power Meter; includes 300A CT (Inside diameter 36 mm; wire lead 4 m) x 24 (RoHS)
PM-4324A-400P-CPS CR	CANopen, Multi-Circuit Power Meter; includes 400A CT (Inside diameter 36 mm; wire lead 4 m) x 24 (RoHS)

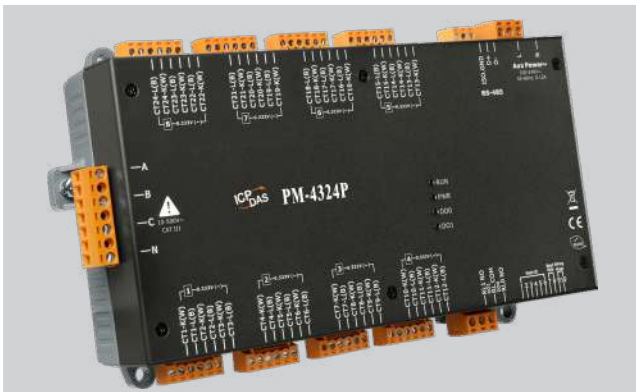

PM-4324P/-MTCP/-CPS
Multi-circuit Smart Power Meter

Features

- Bi-directional Energy
- 8 Three Phase Circuits or 24 Single Phase Circuits
- True RMS Power Measurements
- Energy Analysis for 3P4W, 3P3W, 1P3W, 1P2W
- Measure different current ranges with different 333mV CTs
- Voltage Measurements Up to 500 V
- W Accuracy Better than 5% (PF=1)
- Total Harmonic Distortion (THD)
- Support RS-485, Ethernet or CAN bus Interface
- Support 2 Power Relay Output (Form A)



Introduction

The PM-4324P series multi-circuit power meter monitors up to 8 three-phase circuits or 24 single-phase circuits, or any combination of single or three-phase circuits. The PM-4324P series can measure up to 24 currents via external Current Transformers (CTs). This flexibility makes the PM-4324P series perfect for multi-tenant facilities such as residential projects, office buildings and shopping malls. This compact instrument is designed to easily fit into existing panelboards or be flush mounted nearby, thus eliminating the need for expensive retrofit projects or for allocating extra space for the device. You can use CT's that you currently own with PM-4324P (without CTs) Power Meter. The CT inputs of the PM-4324P can be directly input from the secondary side of 333mV CT.

Specifications

Models	PM-4324P	PM-4324P-MTCP	PM-4324P-CPS
AC Power Measurement			
Wiring	3P4W-3CT, 3P3W-2CT, 3P3W-3CT, 1P2W-1CT, 1P3W-2CT		
Measurement Voltage	10 to 500 V		
Measurement Current	Measure different current ranges with different 333mV CTs		
Measurement Frequency	50/60 Hz		
W Accuracy	Better than 5% (PF=1)		
Power Parameter Measurement	True RMS voltage (Vrms), True RMS current (Irms), Active Power (kW), Active Energy (kWh), Apparent Power (kVA), Apparent Energy (kVAh), Reactive Power (kVAR), Reactive Energy (kVARh), Power Factor (PF), Frequency		
Data Update Rate	1 Second		
Communication			
Interface	RS-485	Ethernet	CAN Bus
Protocol	Modbus-RTU	Modbus TCP	CANopen
Baud Rate	9600, 19200 (default), 38400, 115200; DIP Switch Selectable	-	125 k (default), 250 k, 500 k, 1 M; DIP Switch Selectable
Data Format	N,8,1(default); N,8,2; E,8,1; E,8,2; O,8,1; O,8,2	-	-
Isolation	3000 V _{DC}	-	3000 V _{DC}
Alarm Output			
Power Relay	Form A (Normal Open) x 2; Relay Contact Voltage Range: 5 A @ 250 V _{AC} (47 to 63 Hz), 5 A @ 30 V _{DC}		
Power			
Input Range	+85 to +264 V _{AC}		
Power Consumption	6 W		
Mechanical			
Dimensions / Casing	237 mm x 52 mm x 134 mm (W x L x H) / Plastic		
Module Installation	DIN-Rail Mounting		
Environment			
Temperature	Operating Temperature: -20 to +70°C / Storage Temperature: -25 to +80°C		
Ambient Relative Humidity	10% to 90% RH, Non-condensing		

Wire Connections

Dual Main Circuit 3P4W + 1P2W

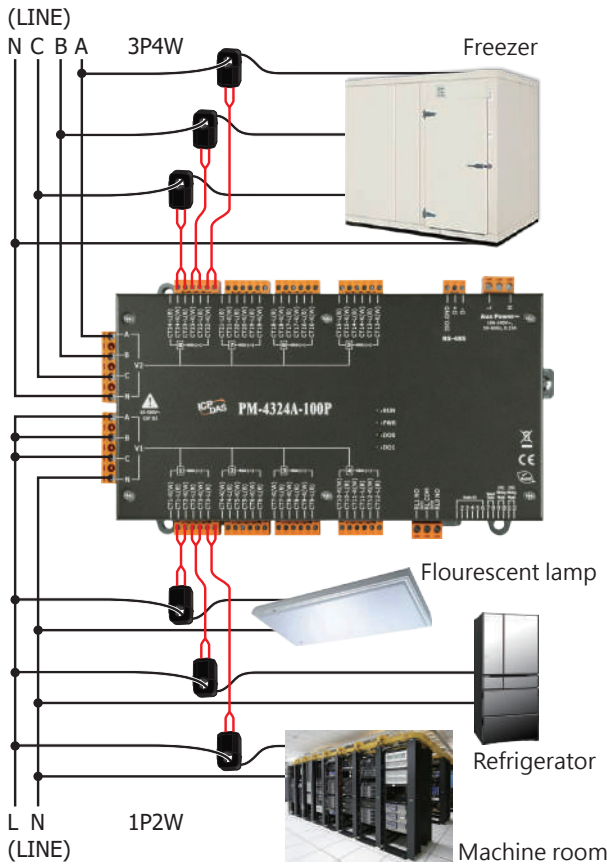

Single Main Circuit 3P3W

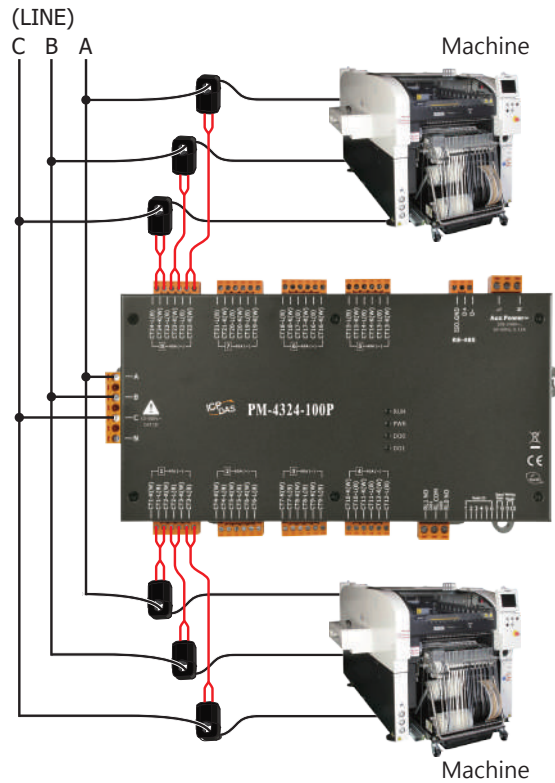

Appearance

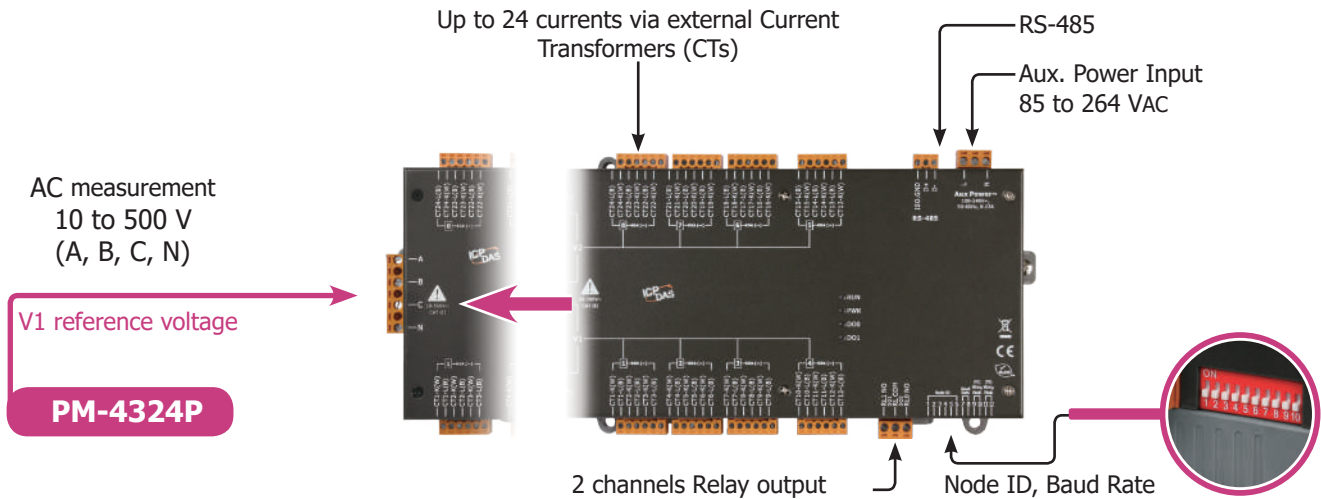

Ordering Information

RS-485 Interface	
PM-4324P CR	Modbus RTU, Multi-Circuit Power Meter (Can be directly input from the secondary side of 333mV CT) (RoHS)
Ethernet Interface	
PM-4324P-MTCP CR	Modbus TCP, Multi-Circuit Power Meter (Can be directly input from the secondary side of 333mV CT) (RoHS)
CAN bus Interface	
PM-4324P-CPS CR	CANopen, Multi-Circuit Power Meter (Can be directly input from the secondary side of 333mV CT) (RoHS)

5.6 EtherCAT Smart Power Meter Solutions

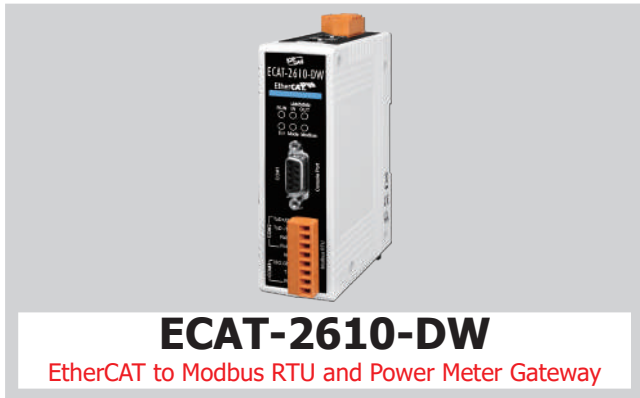

Features

- Supports maximum 128 Input and Output Data
- Supports maximum 6 connection for PM-3033/3133
- 2 x RJ-45 bus interface, Integrate RS-232/422/485 serial device to EtherCAT
- Allows system integrators to retro-fit older automation devices into modern EtherCAT communication structures
- Supports blended to other Modbus slave
- Supports maximum Baud Rate 115200 bps

Introduction

ECAT-2610-DW has EtherCAT to Modbus RTU gateway function, and integrate power meter slave devices such as PM-3033/3133/3114/3112 into EtherCAT control system through the special configuration file that provided by ICP DAS. And very easy to install and configure. The EtherCAT master can access RxPDO and TxPDO to connect multiple power meter slave devices such as PM-3033/3133/3114/3112. It can achieve a more diversified energy management program.

Applications

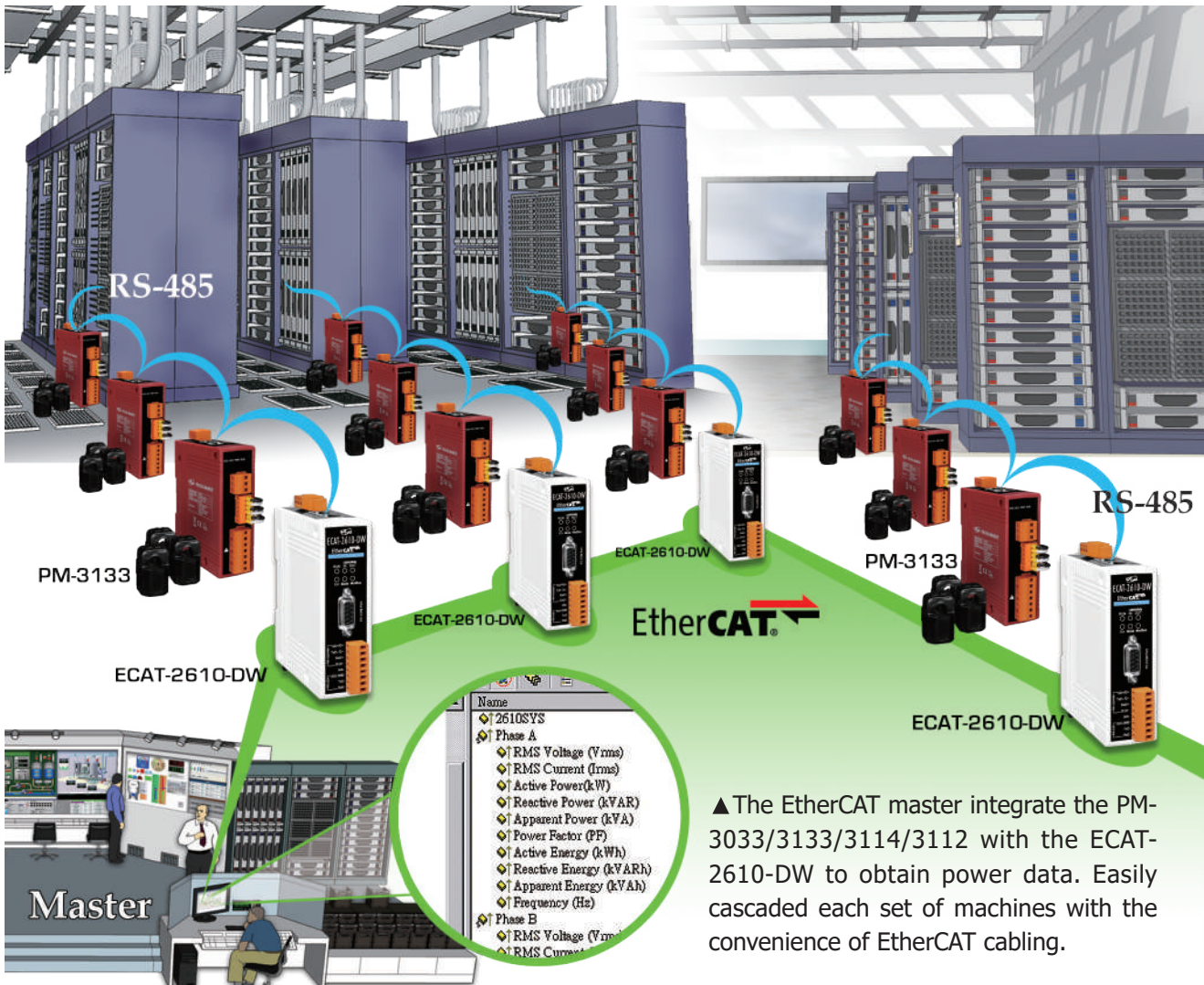

▲ The EtherCAT master integrate the PM-3033/3133/3114/3112 with the ECAT-2610-DW to obtain power data. Easily cascaded each set of machines with the convenience of EtherCAT cabling.

▲ Use ICP DAS to provide dedicated ESI files to display power information.

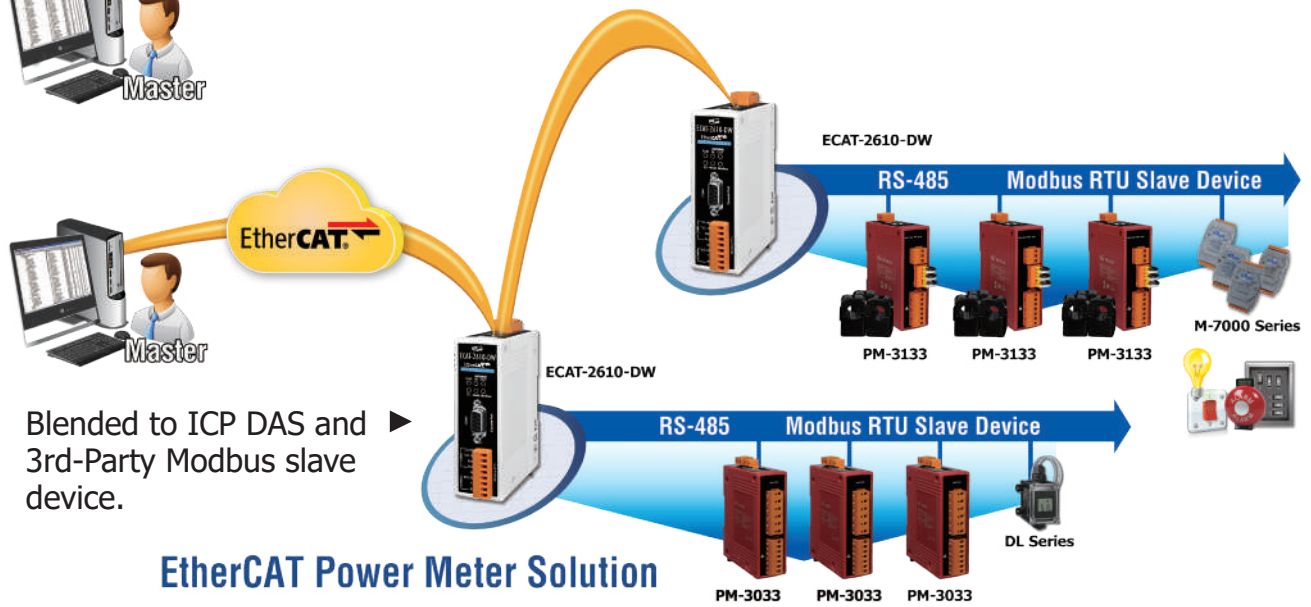
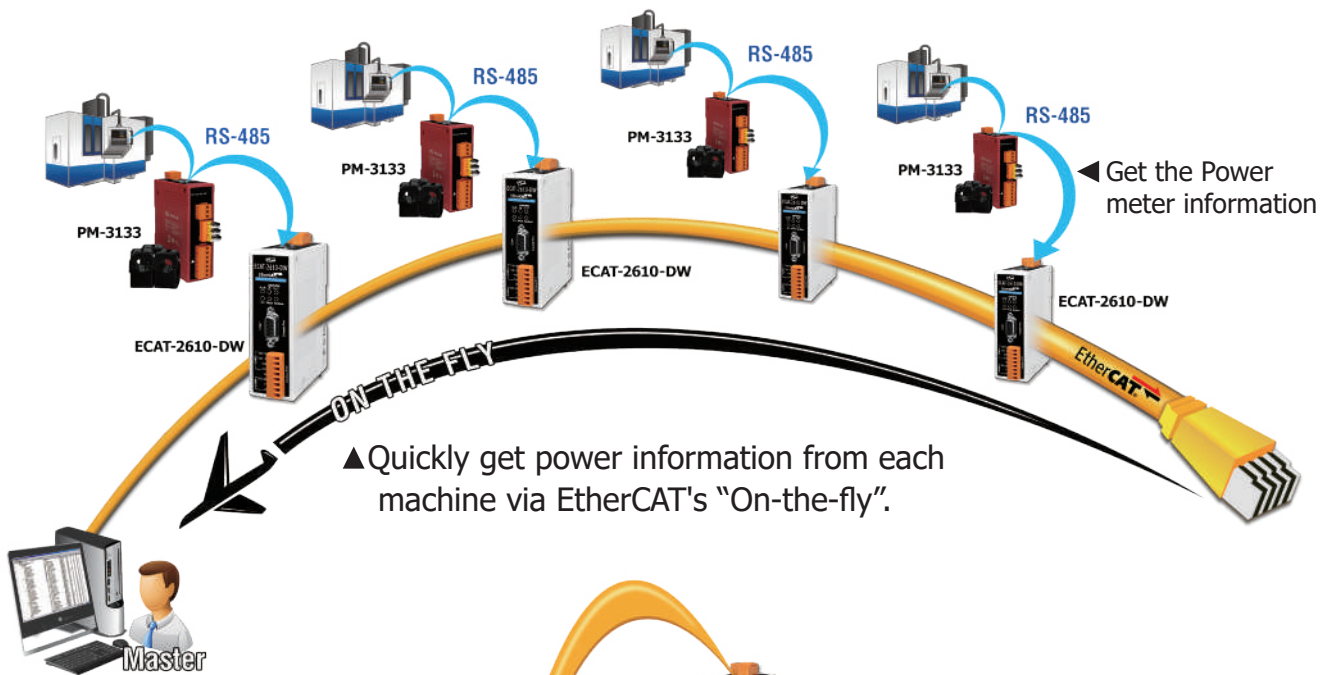

EtherCAT Power Meter Solution

Specifications

Protocol	
Protocol	EtherCAT
Communication Interface	
RJ-45 Port	RJ-45 x 1 Distance between Stations: Max. 100 m (100BASE-TX) Data Transfer Medium: Ethernet/EtherCAT Cable (Min. CAT 5e)
Serial Interface	RS-232
	RS-422
	RS-485
The RS-232, RS-422 and RS-485 cannot be used simultaneously	
<ul style="list-style-type: none"> ■ TxD, RxD, GND ■ TxD+, TxD-, RxD+, RxD- ■ Data+, Data- 	

Ordering Information

ECAT-2610-DW CR	EtherCAT to Modbus RTU and Power Meter Gateway (RoHS)
-----------------	---

5.7 PROFINET Smart Power Meter Solutions



GW-7662

PROFINET to Modbus RTU/ASCII Gateway

Features

- PROFINET Gateway
- Modbus RTU master
- Protocol: PROFINET IO Device
- Generic GSDML File Provided (Version 2.25)
- Max length of input/output data is 512/512 Bytes
- Max baud rate for COM1: 460.8kbps
- Connect up to 22 PM-3033/3133 devices
- Support Daisy Chain



Introduction

GW-7662 is a PROFINET to Modbus RTU gateway. It can connect several PM-3033/3133/3114/3112 devices via RS-485 in Modbus side, and then PROFINET controller can access the electronic information from GW-7662. PM-3000 series device can access to real-time electric usage for single-phase/three-phase power measurement, and it also support Modbus RTU protocol that makes GW-7662 access these measured values easily.

Applications

Ethernet Switch
FSM-6228

PLC I/O Controller

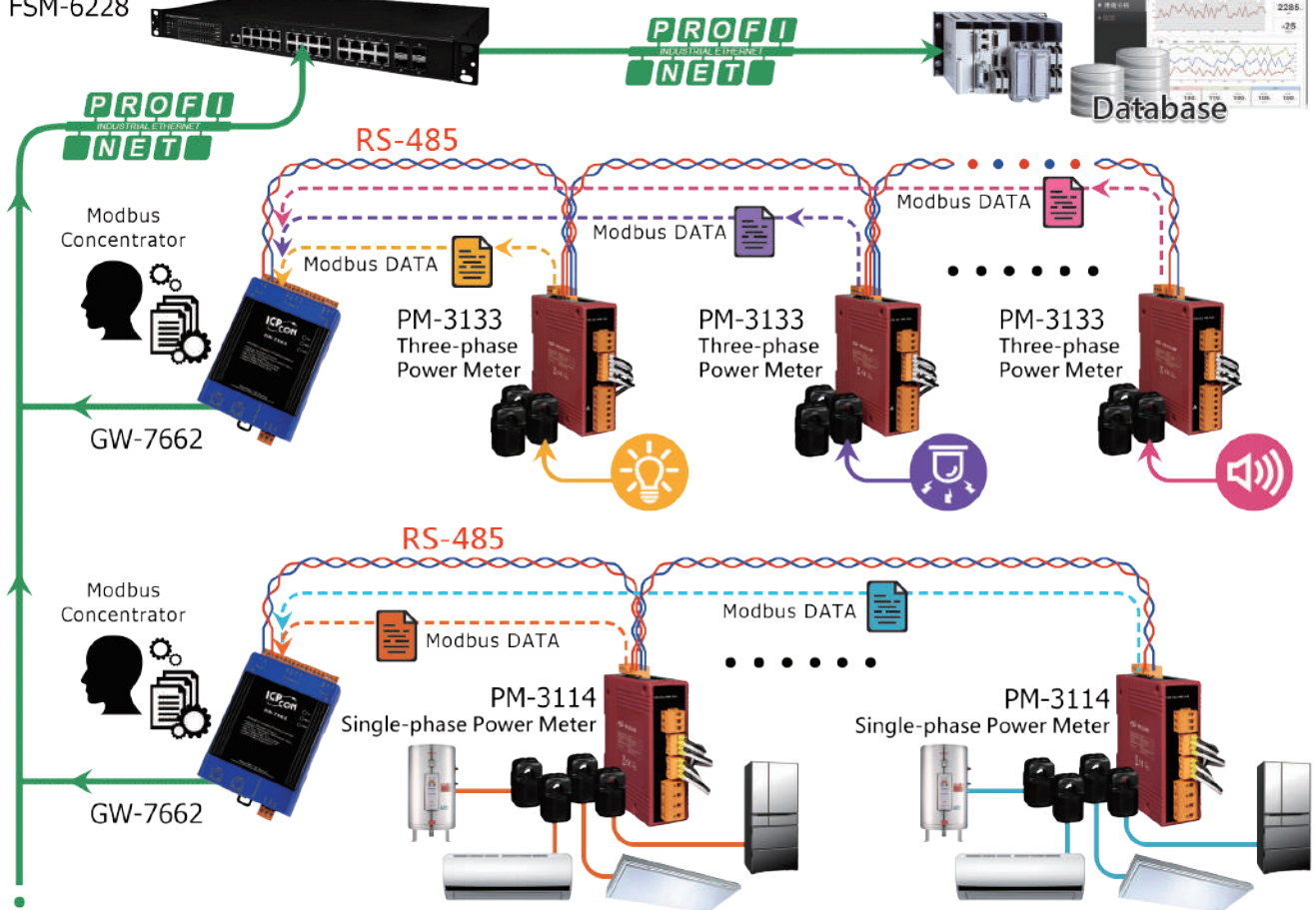

▲GW-7662 Can integrate the electronic information of the several devices into PROFINET system, the user can manage these electronic information via PROFINET controller.



▲The User can quickly access the electronic information of all the devices via PROFINET high speed transmission.

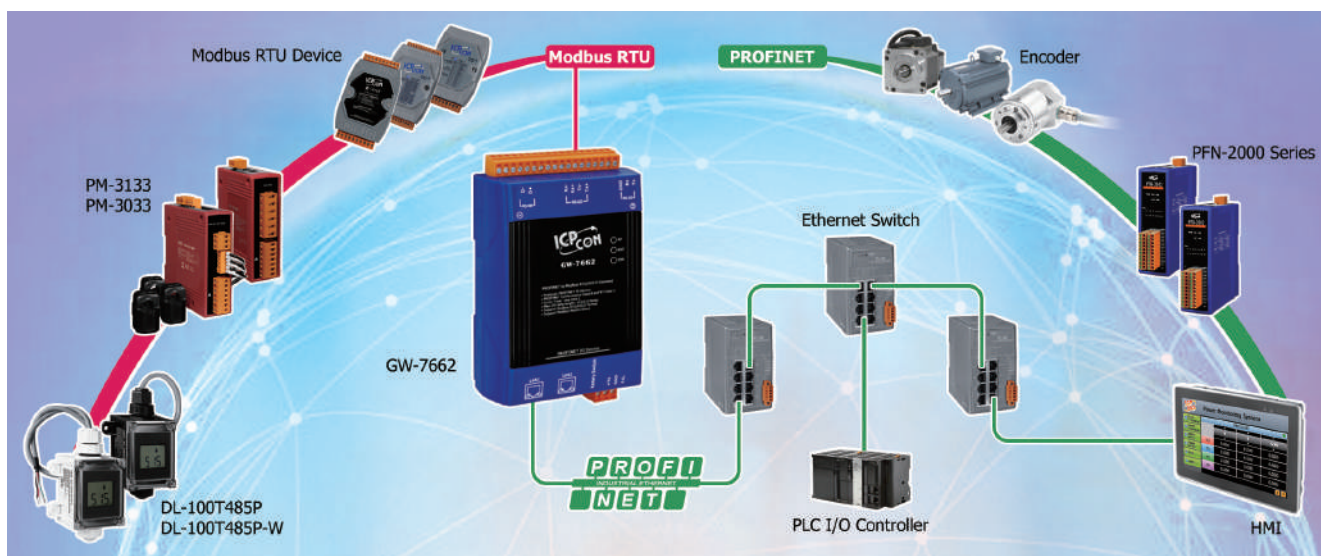

▲GW-7662 can connect PM-3033/3133/3114/3112 device and other ICP DAS's Modbus RTU slave modules in the same time.

System Specifications

Protocol	
Slave	PROFINET IO
Master	Modbus RTU
Interface	
Ethernet	10/100 Base-TX, 8-pin RJ-45 x 2, (Auto-negotiating, Auto-MDI/MDIX)
UART (COM1)	2-wire RS-485, 4-wire RS-422, 3-wire RS-232

Ordering Information

GW-7662 CR	PROFINET to Modbus RTU/ASCII Gateway (RoHS)
------------	---

5.8 EtherNet/IP Smart Power Meter Solutions

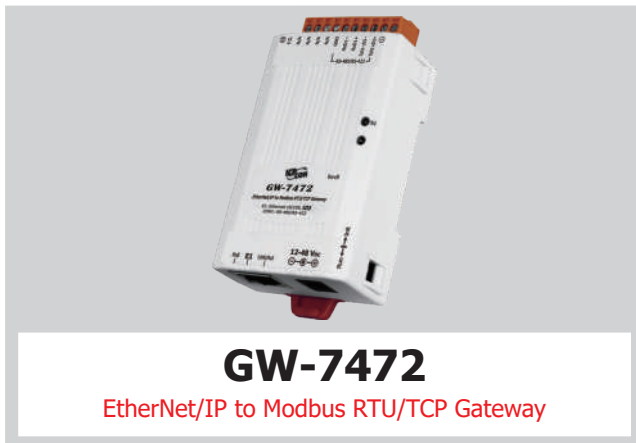

GW-7472

EtherNet/IP to Modbus RTU/TCP Gateway

Features

- EtherNet/IP adapter
- Modbus RTU Master
- Modbus TCP/IP Client
- Maximum EtherNet/IP Input/Output data size: 500 bytes
- Support 1 Implicit connection
- Support Daisy Chain
- The Ethernet upgrade is supported



Introduction

GW-7472 is an EtherNet/IP to Modbus RTU/TCP gateway. The GW-7472 Modbus RTU can connect with PM-3033/3133/3114/3112 via RS-485 daisy chain. Users can also set commands in the GW-7472, and then polls the data from PM-3033. Then PLC can get all the data of power meters in the GW-7472 registers by EtherNet/IP. This is a much more convenient way for power meter management. GW-7472 supports Network Topology, and we can use Ethernet Switch to expand the topology. Furthermore, GW-7472 is easy to install with PoE function.

Applications

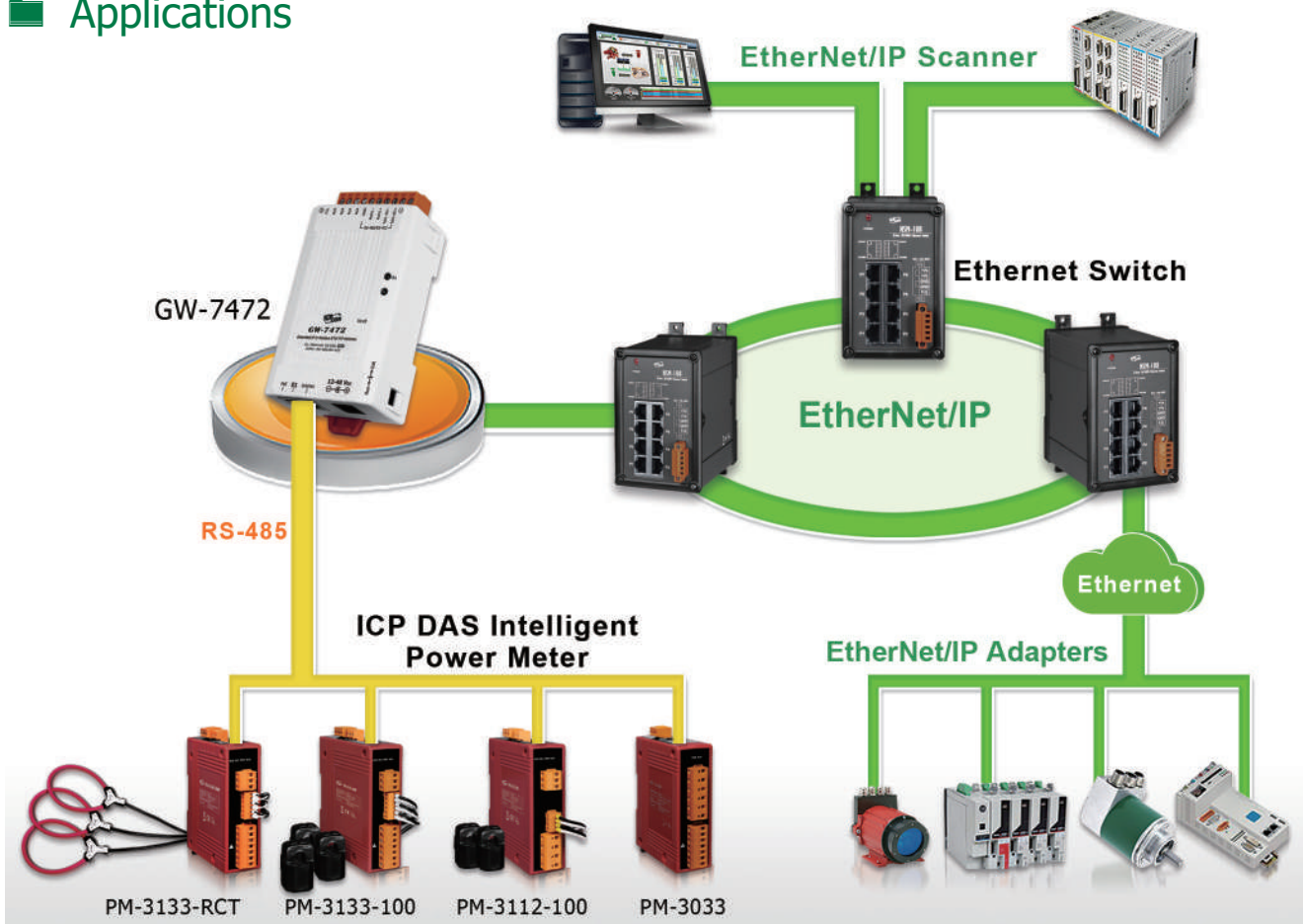

▲With Modbus polling, GW-7472 gets data from power meters and put them into internal registers. PLC can get the data from GW-7472 via EtherNet/IP.

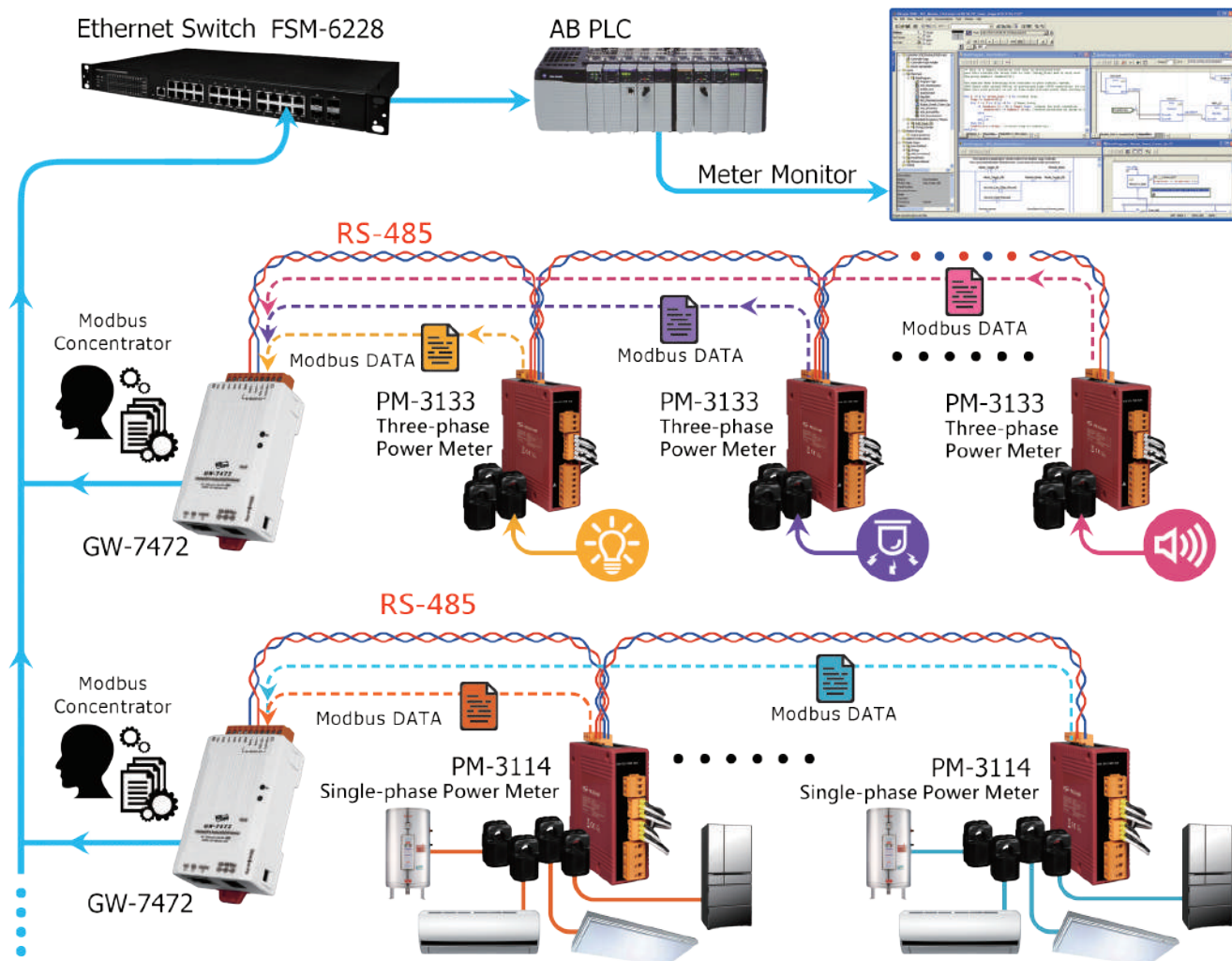

▲The GW-7472 can automatically get the data of power meters with polling commands, and users can obtain the status of PM-3033/3133/3114/3112 from the interface of EtherNet/IP.

System Specifications

Protocol	
Slave	EtherNet/IP adapter
Master	Modbus RTU Master Modbus TCP/IP Client
Ethernet Interface	
Ethernet	10/100 Base-TX, 8-pin RJ-45 x 1, (Auto-negotiating, Auto-MDI/MDIX, LED indicator) PoE (IEEE 802.3af, Class 1)
UART (COM1)	2-wire RS-485 4-wire RS-422

Ordering Information

GW-7472 CR	Tiny EtherNet/IP to Modbus RTU/TCP gateway with PoE and 1 RS-422/485 (RoHS)
------------	---

Ch6. True RMS Input Module

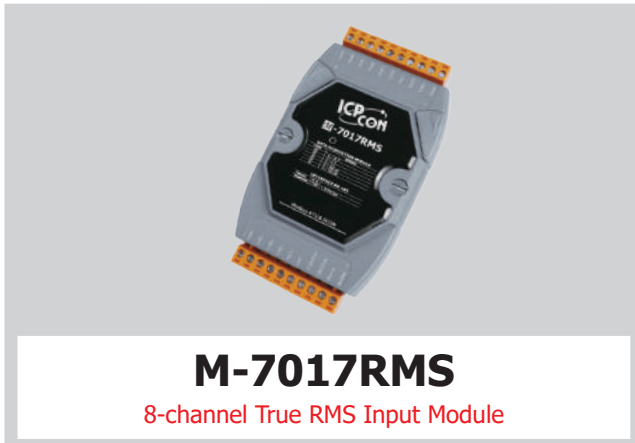

Features

- 8-channel True RMS Input
- $\pm 0.15\%$ Factory Calibrated Accuracy
- The RMS input range: $+150 \text{ mV}_{\text{rms}}$ to $+10 \text{ V}_{\text{rms}}$
- For Standard Operation with Frequencies: 45 Hz to 10 KHz
- Individual Channel Configurable



Introduction

The M-7017RMS is an 8-channel differential AC input module that is used to convert the AC input signals to their True RMS DC values. The RMS input range can be from $+150 \text{ mV}_{\text{rms}}$ to $+10 \text{ V}_{\text{rms}}$, and each channel can be configured individually. The M-7017RMS is a complete, high-accuracy, RMS-to-DC converter that computes the True RMS DC value of any complex waveform. It also features 4 kV ESD protection, 2500 V_{DC} intra-module isolation and $\pm 35 \text{ V}_{\text{DC}}$ overvoltage protection.

System Specifications

Communication	
Interface	RS-485
Bias Resistor	No (Usually supplied by the RS-485 Master. Or, add a tM-SG4 or SG-785.)
Baud Rate	1200 to 115200 bps
Protocol	Modbus RTU, DCON
Dual Watchdog	Yes, Module (1.6 Seconds), Communication (Programmable)
LED Indicators/Display	
System LED Indicator	1 as Power/Communication Indicator
Isolation	
Intra-module Isolation, Field-to-Logic	2500 V _{DC}
EMS Protection	
ESD (IEC 61000-4-2)	$\pm 4 \text{ kV}$ Contact for each Terminal
	$\pm 8 \text{ kV}$ Air for Random Point
EFT (IEC 61000-4-4)	$\pm 4 \text{ kV}$ for Power Line
Surge (IEC 61000-4-5)	$\pm 0.5 \text{ kV}$ for Power Line
Power	
Reverse Polarity Protection	Yes
Input	$+10 \text{ to } +30 \text{ V}_{\text{DC}}$
Consumption	0.9 W
Mechanical	
Dimensions (L x W x H)	123 mm x 72 mm x 35 mm
Installation	DIN-Rail
Environment	
Operating Temperature/ Storage Temperature	$-25 \text{ to } +75^\circ\text{C}/-40 \text{ to } +85^\circ\text{C}$
Humidity	10 to 95% RH, Non-condensing

Applications

- Building Automation
- Factory Automation
- Machine Automation
- Remote Maintenance
- Remote Diagnosis
- Testing Equipment

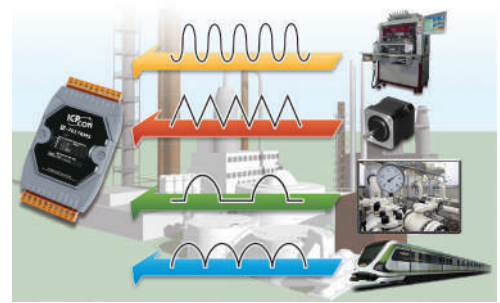

I/O Specifications

Analog Input		
Channels	8	
Wiring	Differential	
Input Range	0 to $+10 \text{ V}_{\text{rms}}$, 0 to $+5 \text{ V}_{\text{rms}}$, 0 to $+1 \text{ V}_{\text{rms}}$, 0 to $+500 \text{ mV}_{\text{rms}}$, 0 to $+150 \text{ mV}_{\text{rms}}$	
Resolution	16-bit	
Accuracy		
Sinusoid	50/60 Hz	$\pm 0.15\%$ of FSR
	45 Hz to 10 Hz	$\pm 0.5\%$ of FSR
Non-Sinusoid	Crest Factor=1 to 2	$\pm 0.2\%$ of FSR
	Crest Factor=2 to 3	$\pm 0.35\%$ of FSR
DC	0 to $+10 \text{ V}_{\text{rms}}$ / 0 to $+5 \text{ V}_{\text{rms}}$ / 0 to $+1 \text{ V}_{\text{rms}}$	$\pm 0.3\%$ of FSR
	Other	$\pm 0.7\%$ of FSR
Sampling Rate	10 Hz (Total)	
-3dB Bandwidth	15.7 Hz	
Zero Drift	$\pm 20 \mu\text{V}/^\circ\text{C}$	
Span Drift	$\pm 25 \text{ ppm}/^\circ\text{C}$	
Common Mode Rejection	86 dB	
Normal Mode Rejection	100 dB	
Input Impedance	$> 2 \text{ M}\Omega$	
Individual Channel Configuration	Yes	
Overvoltage Protection	$\pm 35 \text{ V}_{\text{DC}}$	

Production traceability and online real-time alarm for machining processes

The previous system can only record the production order and the stack light status of the machines. For only a few simple information can be collected, it was not sufficient to assist the production engineers to further analysis or source the cause/signs of the machine failure. As we know, the data of generated current during motor operation is a key information to diagnose the health status of the machines and the quality of the machining processes.

■ The remote data acquisition system provided by ICP DAS is as follows:

Hardware: The M-7017RMS + DN-800 series daughter board.

Software: EZ Data Logger

EZ Data Logger is a simple data acquisition software that allows you to quickly and easily build a data acquisition system. It provides a free version that supports up to 64 I/O points, for small scale data acquisition, and will save you the cost in purchasing extra software.

■ Benefit of ICP DAS solution:

The solution provided by ICP DAS features stable and easy-to-install hardware, easy-to-use software and no programming required. It is a very helpful tool for engineers in production line to get more detailed data records on the production machine, fault analysis, and propose improvement plans. And furthermore improve the utilization rate and the production quality of the machines.

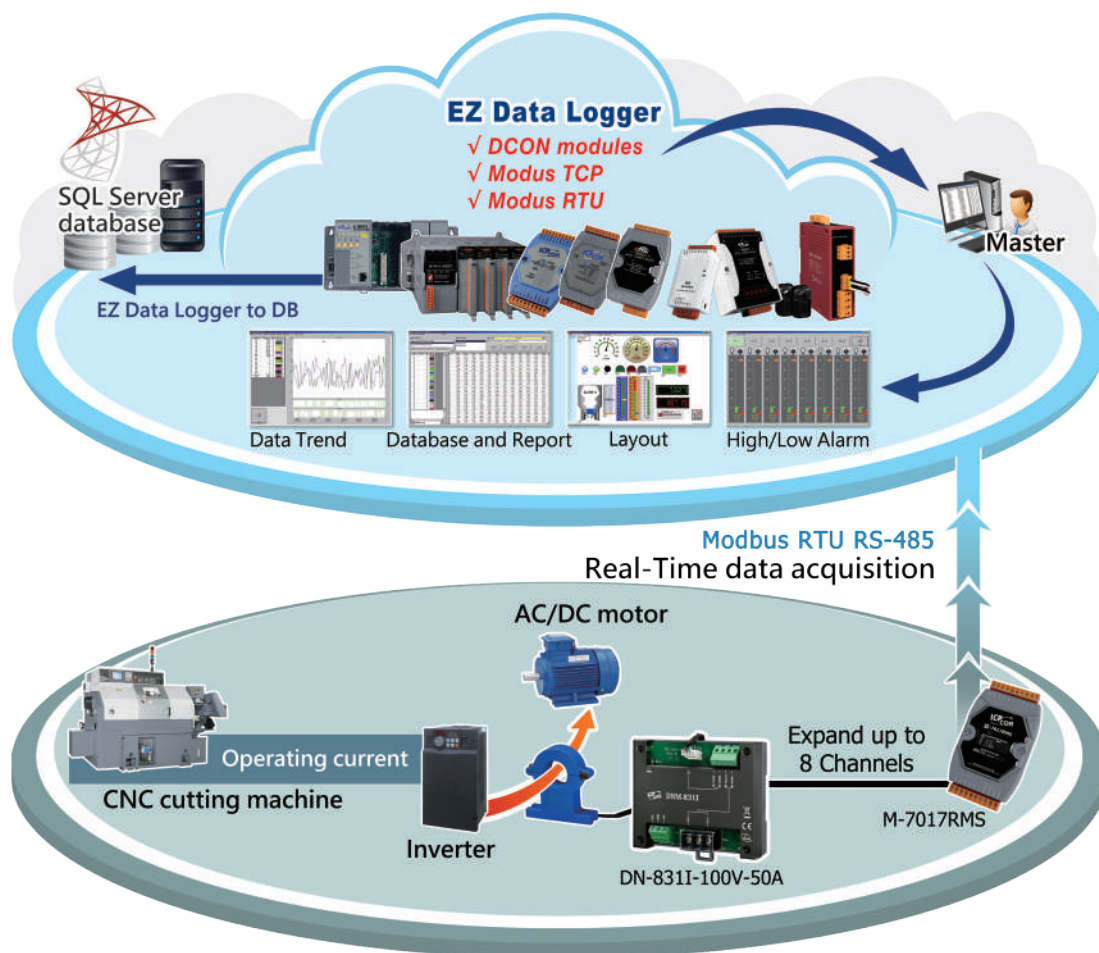

Ordering Information

M-7017RMS-G CR	8-channel True RMS Input Module (Gray Cover) (RoHS)
----------------	---

Accessories

DN-800 Series	Voltage Attenuator and Current Transformer
---------------	--

Ch7. Voltage Attenuator and Current Transformer: DN-800 Series

DN-800 series is a Voltage Attenuator and Current Transformer designed for used in high-voltage applications. The current can be converted into +/-10 Vpp attenuated signal, so that a general electronic measuring device is able to read the signals. Compared to ICP DAS power meter products (PM-3033, PM-3133, PM-4324, etc.), in addition to AC signals, the DN-800 series can convert DC signals as well.

The users can use appropriate ICP DAS Remote I/O Modules such as: M-7017R, I-87017RW, or ET-7217 to measure the converted +/-10 VDC signal via DN-800 series. And use M-7017RMS or I-87017W-RMS, etc. to measure the AC signals.

By using DN-800 series, the power data of all kinds of machines and AC/DC motors can be easily measured and retrieved, and then the analyzed data can be used to develop a model to build a failure warning system.

Applications

The operating current of AC or DC motor of the machines is converted into +/-10 Vpp attenuated signal via DN-844, and then the +/-10 Vpp signal is converted based on Modbus/RTU protocol for seamless integration with all kinds of PLC or SCADA.

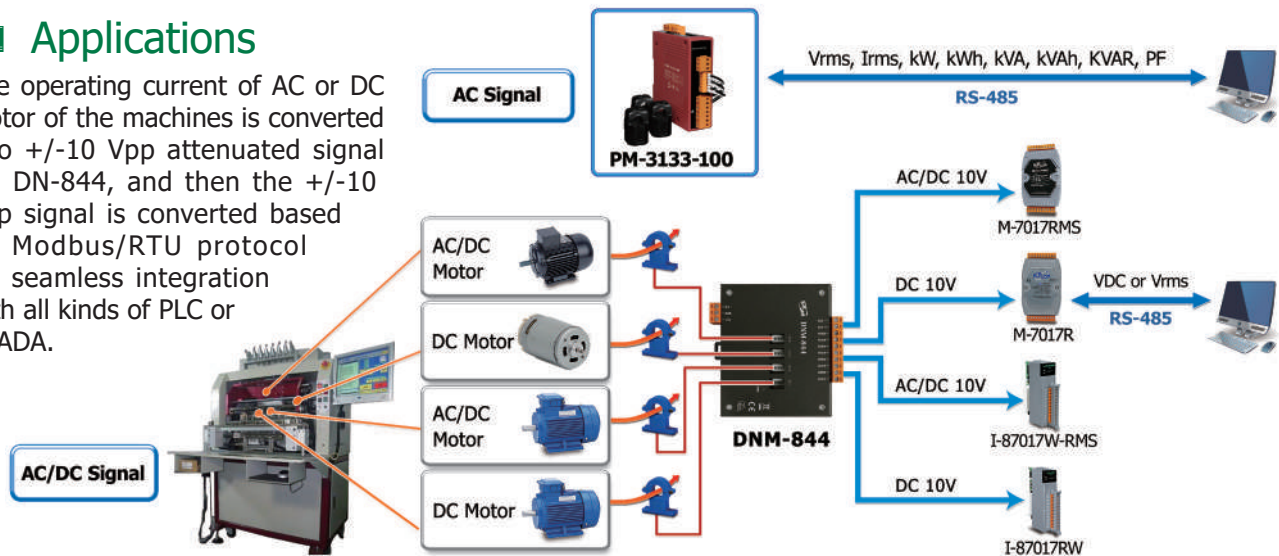

Appearance & Specifications

Model	Input Channel	Input Type	Input Range	CT Type	Cable	Output
 DNM-831I-100V-50A DNM-831I-100V-200A DNM-831I-100V-500A	1 × Voltage, 1 × Current	AC/DC	±100 Vpp, ±50 A	Clip-on Ø21 mm	1.5 m/2.5 m	±10 Vpp
			±100 Vpp, ±200 A			
			±100 Vpp, ±500 A			
 DNM-831I-100V-1000A DNM-831I-100V-2000A			±100 Vpp, ±1000 A	Clip-on Ø40.5 mm	1.5 m	
			±100 Vpp, ±2000 A			
 DNM-844-200A DNM-844-500A	4 × Current	AC/DC	±50 A	Clip-on Ø21 mm	1.5 m/2.5 m	±10 Vpp
			±200 A			
 DNM-844-2000A			±500 A	Clip-on Ø40.5 mm	1.5 m	
			±1000 A			
 DN-843VI-600V	3 × Voltage	AC/DC	±600 Vpp	N/A	N/A	±10 Vpp
 DN-848VI-10V DN-848VI-80V DN-848VI-150V	8 × Voltage	AC/DC	±10 Vpp	N/A	N/A	±10 Vpp
			±80 Vpp			
			±150 Vpp			
 DN-843I-CT-10 DN-843I-CT-20 DN-843I-CT-50	3 × Current	AC/DC	±1 A	Solid Core (closed)	N/A	±1.6 Vpp, ±10 Vpp, ±10 Vpp, ±4 Vpp
			±10 A			
			±20 A			
			±50 A			

Ch8. iWSN Solution

iWSN Series (Industrial Wireless Sensor Network)

8.1 Overview

The iWSN modules integrate current, temperature measurement, and wireless transmission functions into a single module, the ultra low power consumption can be matched with a current transformer (CT) for inductive charging. It can meet the supply and demand balance of working power and supply the required continuous uninterrupted measurement equipment parameters with sufficient power. The settings can be completed using a DIP switch, which not only doesn't affect the production process, but also greatly saves system construction time and reduces maintenance costs. To meet the power consumption needs of monitoring equipment, predictive maintenance and power panel temperature monitoring, it's helpful to maintain the production line equipment and prevent accidents caused by the aging of power panel equipment and cables.

8.2 Applications

- Strengthen the safety and management efficiency of plant and equipment
- Analyze and improve product costs
- Avoid unnecessary energy waste
- Analysis history reports and graphs
- Improve electricity safety and reduce the chance of failure
- Alarm logging and proactive notification
- Improve the management efficiency of factory staff



8.3 Power Measurement Solutions

① Create Data Acquisition System

- Centralized management and control of power information for industry and manufacturing.
- Establish a complete management system.
- Record and analyze data, master the energy consumption indicators of equipment, and realize preventive maintenance.

② Create Management System

- Realize data analysis, data forecasting, and database technology.
- Monitor data such as equipment temperature, vibration, energy consumption status, and production environment
- Regular output of daily and monthly reports, and annual reports.

Power Measurement Solution

③ Regulate Control System

- Help industrial enterprises propose energy saving measures to reduce emissions.
- Improve the operation management and automation of energy equipment.
- Reduce energy costs based on objective data and improve corporate profitability.

④ Save Power & Reduce Emissions

- Equipment management and operating status are evaluated based on real data.
- Keep abreast of real power consumption and propose management measures for power conservation and consumption reduction.
- Improve the efficiency of power management.

8.4 System Architecture & Applications

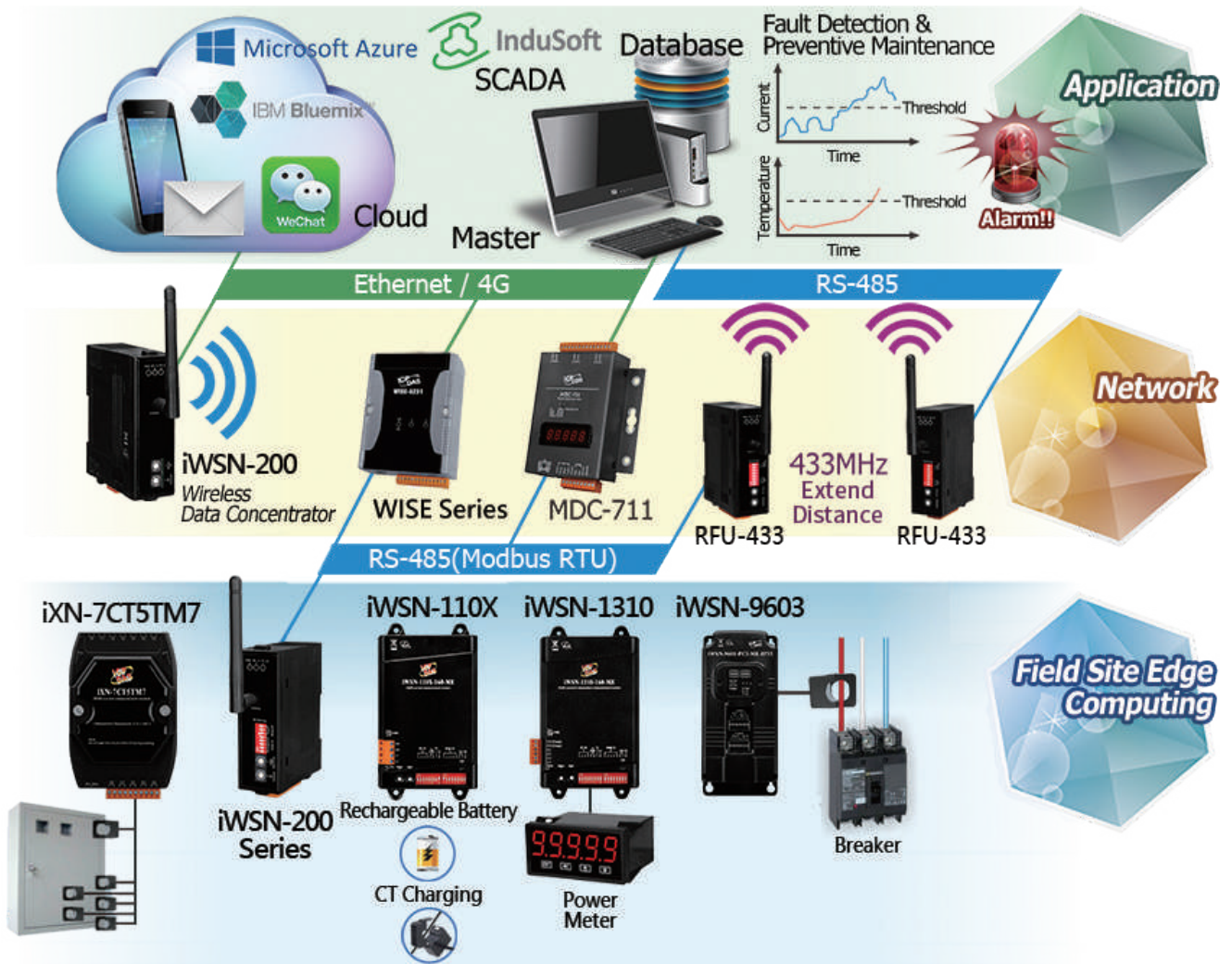

Machine Diagnosis

When the machine is in normal operation, the current and temperature will meet the normal range. Abnormal data may indicate that the machine is in abnormal working state. If maintenance is not arranged immediately, it may cause serious damage to the machine and even affect the safety of the operator, resulting in industrial safety accidents. If parts are found to be worn out after machine maintenance, you can plan a warranty plan and prepare spare parts in advance. So that the production line can properly plan production capacity and avoid accidents that cause production line stagnation and raw material scrap loss.

- Use iWSN-110X-160-ME with iXN-7CT5TM7 to monitor current and temperature.
- According to the correlation between temperature and consumption of the machine recorded, an alarm will be issued and troubleshooting will be performed when the machine is working abnormally or overloaded.
- Avoid forced operation to cause more serious damage to the machine and expand losses.

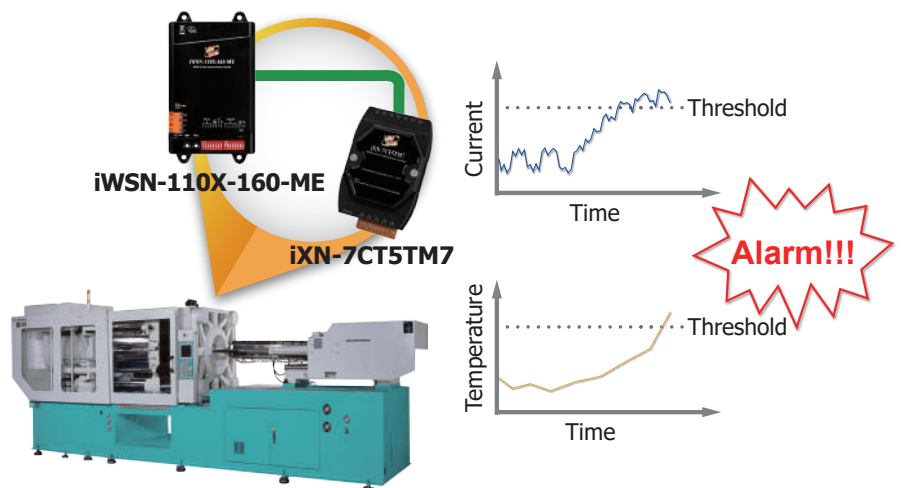

Activation Monitoring

The floorspace of some factories is large and contains a lot of equipment. If the owner of the factory can keep track of the production status of each machine, the problem where the waiting time or standby time is too long can be avoided. The traditional method is for the employees to fill in the operating time themselves. Not only does it take time to organize this information, it is also impossible to control the artificial floating time behavior and dynamically understand the productivity of the production line machine. The iWSN network system provides the staff with an instant understanding of the operating status of the field production line, while, in addition, also giving an indication where any necessary raw materials need to be immediately replenished, allowing the machine to continue to operate efficiently and achieve optimal production capacity.

- Use the iWSN-121A-240-ME module to monitor the current data on the panel.
- The two CT channels on the iWSN-121A-240-ME module are used to detect the total current consumption of both the device and the main motor so as to determine whether the machine is in either standby or running condition.



Machine Room Power Monitoring

A wireless data collection network can be used with iWSN-200U and iWSN-9603-PCT-ME-IP33, and one iWSN-200U can collect up to 31 iWSN-9603-PCT-ME-IP33 in 10/30/60 seconds. Also, an iWSN-9603-PCT-ME-IP33 can connect up to 6 CTs to measure the power of 6 circuits.

Therefore, a wireless data collection network can collect power data of 180 loops in total. In addition, each wireless data collection network can operate independently on 16 wireless channels without mutual influence, so a total of 2880 circuits can be collected for power information. Users only need to communicate with iWSN-200U through Modbus RTU, and then they can read back the power data returned by iWSN-9603-PCT-ME-IP33.

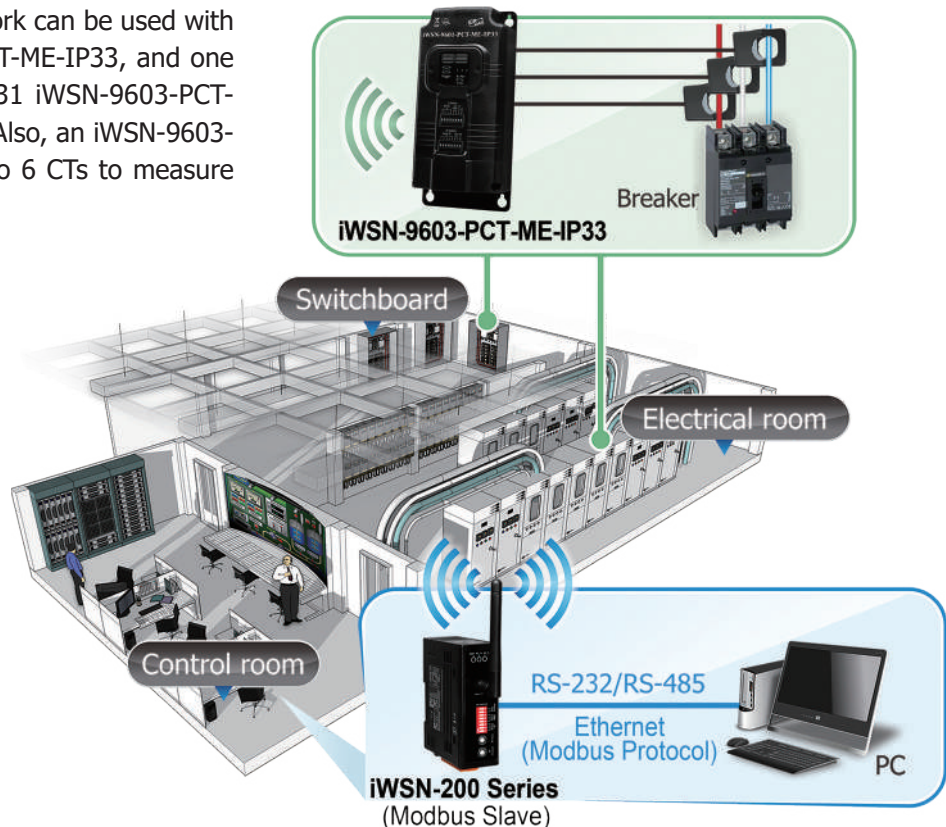

8.5 Wireless Data Concentrator



iWSN-200U / 200R / 200E

Accessories



Antenna Magnetic Base: ANT-Base-02
Antenna magnetic base with 1.5M cable

Antenna Extension Cable: 3S001-1
RG58A/U, RP-SMA Male to RP-SMA Female, 1M



The **iWSN-200** series is wireless data concentrator in the iWSN system, providing 433MHz wireless, Ethernet, RS-232/RS-485 communication interfaces. The series supports the Slave function of the Modbus RTU/TCP communication protocol, allows users to access the data of 31 iWSN wireless signal sensing modules. It can set 16 wireless channels and 8 group numbers, which is convenient to distinguish and control the wireless network of 433 MHz.

Models	iWSN-200U	iWSN-200R	iWSN-200E
RF Interface			
Radio Frequency	433 MHz		
Channels	0 to 15 configured by DIP switch		
Transmission Distance	LoS 100 M		
Connectivity	Supports up to 31 iWSN wireless signal sensing modules		
Communication			
Interface	RS-232 and RS-485 x 1	RS-485 x 1	Ethernet x 1
Protocal	Modbus RTU		Modbus TCP
Transmission Speed	1200 to 115200 bps, N81		10/100 Mbps
Relay Output			
Channels	1 (Form A)		-
Type	Power Relay (SPST N.O.)		
Power Relay (Form A)	Load Current (Max.)	5A @ 250VAC 5A @ 30VDC	
	Operate Time	10ms (Max.)	
	Release Time	5ms (Max.)	
Mechanism			
Dimension (L x W x H)	108 mm x 84 mm x 33 mm (without antenna)		
Antenna (L x Ø)	108 mm x 10 mm		
Installation	DIN-Rail Mounting		
Other			
Input Voltage Range	+10 to +30 VDC		
PoE Power	-	IEEE 802.3af, Class 1	
Consumption	1W Max.		
Operation Temperature	-25 °C to +75 °C		

8.6 AC Current Sensing Module



iWSN-110X Series

Features:

- Self-powered by built-in a chargeable Li-ion battery.
- Energy harvest from the CT induced electricity.
- Uses 433 MHz radio frequency for communication.
- 16 RF Channels and 4 Group ID, consist of maximum 64 RF sub-networks.
- Provides expansion interface for flexibility and expansibility.

iWSN-110X Series is a self-powered module for AC current. It harvests the demand electricity from CT induced current so that there is no necessary to supply the power line for power supply. By means of sub-1G RF communication interface, iWSN series can approach to the real wireless deployment. The iWSN sensing module can be widely used in the application of saving power, big data analysis, and predict maintenance.

Models	iWSN-110X-PCT-DC	iWSN-110X-PCT-ME	iWSN-110X-160-ME iWSN-110X-240-ME iWSN-110X-360-ME	iWSN-110X-RCT1000P-CT iWSN-110X-RCT1000PL-CT
RF				
Radio Frequency	433 MHz			
Channels	0 to 15 configured by DIP switch			
Transmission Distance	LoS 100 M			
Working Duty	1 / 10 / 30 / 60 sec. configured by DIP switch			
CT				
Channels	Optional CT x 1		Split core CT x 1	1 (Charge only)
Input Voltage	50Hz or 60Hz, 500V (Max.)			
Type	Φ16mm(0.1A to 100A), Φ24mm(0.2A to 200A), Φ36mm(0.3A to 400A) ⁽ⁱ⁾			Φ24mm(0.2A to 200A)
Accuracy	<3% or 0.3A			-
RCT Channels				1
RCT Input Voltage				50Hz or 60Hz, 500V (Max.)
RCT Type				Φ24mm(200A), Φ36mm(400A)
RCT Accuracy				3% or 2A
Mechanism				
Dimension	152 mm x 85 mm x 36 mm (L x W x H)			
Installation	Wall or Magnetic mounting			
Other				
Power	10 to 30 VDC	Rechargeable lithium battery 3.7V, 800mAh x 1 (With overdischarge, overcharge & short-circuit protection; 1.25mm connector)		
Operation Temperature	-25 °C to +75 °C	0 °C to +45 °C		

(i) iWSN-110X-PCT-ME has not attached CT; iWSN-110X-160-ME has attached Φ16mm(100A) CT, iWSN-110X-240-ME has attached Φ24mm(200A) CT, iWSN-110X-360-ME has attached Φ36mm(400A) CT; iWSN-110X-RCT1000P-CT has attached Φ24mm(200A) CT and Rogowski Coil, iWSN-110X-RCT1000PL-CT has attached Φ36mm(400A) CT and Rogowski Coil.

8.7 AC Current/Temperature Expansion Module



iXN-7CT5



iXN-7CT5TM7

Features:

- Supports multi-channel IO expansion
- Allows connecting different measurement range of CTs in one expansion module.
- Powered by iWSN sensing module.
- Easy-to-maintain detachable screw terminal block
- Rail-mounting and magnetic mounting

The iXN expansion module is developed to connect to the iWSN sensing module, in order to extend the current and temperature measurement channels. The iXN expansion module is energized by iWSN sensing module so that there is no external power supply needed.

Models		iXN-7CT5	iXN-7CT5TM7
Split core CT			
Channels		5	
Type		Φ16mm(100A), Φ24mm(200A) and Φ36mm(400A); 8 M ⁽ⁱ⁾	
Input Voltage		60Hz, 500V (Max.)	
Accuracy		<3% or 0.3A	
Thermistor (Optional)			
Channels		-	7
Range/Accuracy			0°C to 80°C / ±2°C
Power			
Input Type		iWSN sensing module powered by audio cable	
Consumption (Including iWSN-110X) ⁽ⁱ⁾	1 sec. Working Duty	20 A	21 A
	10 sec. Working Duty	12 A	13 A
	30 sec. Working Duty	11 A	12 A
	60 sec. Working Duty		
Other			
Dimension		115 mm x 72 mm x 35 mm (L x W x H)	
Installation		DIN-Rail or Magnetic mounting	
Operation Temperature		0 °C to +45 °C	

(i) The minimum required current of the AC cable, this current is used to balance the supply and demand of module charging and power consumption.

8.8 AC Current/Temperature Multiple Sensing Module



Features:

- Self-powered by built-in a chargeable Li-ion battery. Energy harvest from the CT induced electricity.
- Use 433 MHz radio frequency for communication.
- 16 RF Channels and 4 Group IP, consist of maximum 64 RF sub-networks.
- Built-in 2 or 3 CT measurement channels
- iWSN-121A includes a DI channel to measure the output of the equipment.

The iWSN-121A/1310 series is a self-powered modules for AC current. It can harvest the demand electricity from CT induced current so that there is no necessary to supply the power line for power supply.

Models	iWSN-121A-160-ME iWSN-121A-240-ME iWSN-121A-360-ME	iWSN-1310-160-ME iWSN-1310-240-ME iWSN-1310-360-ME iWSN-1310-PCT-ME	iWSN-1310-mA-ME
RF Interface			
Radio Frequency	433 MHz		
Channels	0 to 15 configured by DIP switch		
Transmission Distance	LoS 100 M		
Working Duty	1 / 10 / 30 / 60 sec. configured by DIP switch		
Split core CT			
Channels	2	3	-
Input Voltage	50Hz or 60Hz, 500V (Max.)		
Type	Φ16mm(100A), Φ24mm(200A) and Φ36mm(400A); 8 M ⁽ⁱ⁾		
Accuracy	<3% or 0.3A		
Thermistor (Optional)			
Channels	1		
Range	0 °C to 80 °C		
Accuracy	< 2 °C		
I/O Interface			
Channels	DI (Dry Contact) x 1	-	AI (4 to 20mA) x 3
Other			
Dimension	152 mm x 85 mm x 36 mm (L x W x H)		
Installation	Wall or Magnetic mounting		
Power	Rechargeable lithium battery 3.7V, 800mAh x 1 (With overdischarge, overcharge & short-circuit protection; 1.25mm connector)		
Battery Charging	By inductive charging of split core CT	By current of measured object	
Operation Temperature	0 °C to +45 °C		

(i) iWSN-1310-mA-ME has not attached CT; iWSN-121A-160-ME/iWSN-1310-160-ME has attached Φ16mm(100A) CT, iWSN-121A-240-ME/iWSN-1310-240-ME has attached Φ24mm(200A) CT, iWSN-121A-360-ME/iWSN-1310-360-ME has attached Φ36mm(400A) CT.

8.9 Power Meter

Features:

- Provides 6 100A split current transformers (CT)
- Provides watt-hour information suitable for energy-saving systems
- Supports up to 6 circuits current measurement
- Supports up to 2000A of cable current.
- Adopt power from the AC power source.
No need for external power transformer



iWSN-9601



iWSN-9603

The iWSN-9601 and iWSN-9603 are AC power meters, which provide a voltage input and current CT inputs, and suits measuring the power information of different equipment powered by the same AC source. By means of wireless communication and powering from the measured voltage cable, it can greatly reduce the cost and duration of installation, and satisfy to the demand of distributed deployment and quick setup. Based on the above features, this series is suitable for applications such as energy saving, big data analysis and predictive maintenance.

Models	iWSN-9601-160-ME-IP33 iWSN-9601-240-ME-IP33 iWSN-9601-360-ME-IP33	iWSN-9603-PCT-ME-IP33	iWSN-9603-160-ME-IP33 iWSN-9603-240-ME-IP33 iWSN-9603-360-ME-IP33	iWSN-9603-RCT500P-ME-IP33 iWSN-9603-RCT1000P-ME-IP33 iWSN-9603-RCT2000P-ME-IP33
RF Interface				
Radio Frequency	433 MHz			
Channels	0 to 15 configured by DIP switch			
Transmission Distance	LoS 100 M			
Working Duty	1 / 10 / 30 / 60 sec. configured by DIP switch			
Measurement				
Wiring	1P2W-1CT / 1P3W-2CT	3P4W-3CT / 3P3W-2CT / 3P3W-3CT / 1P2W-1CT / 1P3W-2CT		
Channels	Single-phase x 1		Three-phase x 1	
Input Voltage	110 to 240 VAC, 277VAC		Phase Voltage: 110 to 240 VAC, 277VAC	
Input Frequency	50 Hz or 60 Hz			
Wh Accuracy	± 1%	± 2%	± 1%	
Parameter Measurement	True RMS voltage(Vrms), True RMS current(Irms), Active Power(kW), Active Energy(kWh), Power Factor(PF), Date and time(Year/Month/Date/Hour/Minute/Second)			
CT				
Includes CTs	6			
Type	Split core CT	Optional CT	Split core CT	RCT Rogowski coil
Specification	Φ16mm(100A), Φ24mm(200A) and Φ36mm(400A); 8 M ⁽ⁱ⁾			Φ55mm(500A), Φ80mm(1000A) and Φ105mm(2000A); 4 M ⁽ⁱⁱ⁾
Other				
Dimension	185mm x 85mm x 45mm (L x W x H)			
Operation Temperature	-25°C to +75 °C			

(i) iWSN-9601-PCT-ME-IP33 has not attached CT; iWSN-960x-160-ME-IP33 has attached Φ16mm(100A) CT, iWSN-960x-240-ME-IP33 has attached Φ24mm(200A) CT, iWSN-960x-360-ME-IP33 has attached Φ36mm(400A) CT.

(ii) iWSN-9603-RCT500P-ME-IP33 has attached Φ55mm(500A) CT, WSN-9603-RCT1000P-ME-IP33 has attached Φ80mm(1000A) CT, iWSN-9603-RCT2000P-ME-IP33 has attached Φ105mm(2000A) CT.

Introduction

■ Sub-GHz Wireless Transmission

Great diffraction capability and transmission distance up to 100 meters.

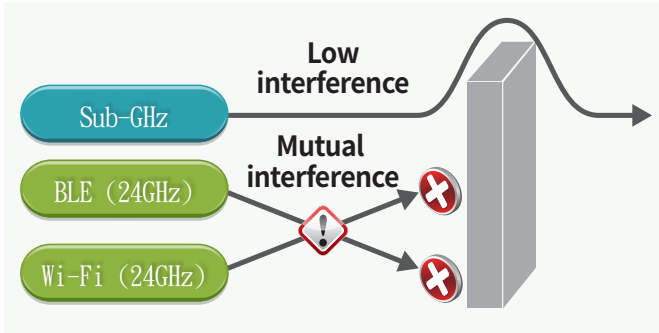

■ Built-in 2A fuse, does not affect mains power supply

Fuse design for uninterrupted production.

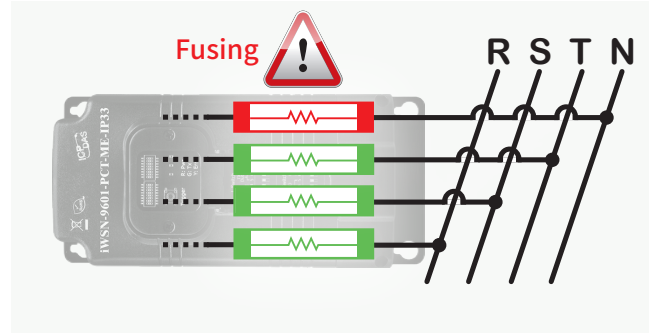

■ Convenient Software Tools

- ◆ Real-time data display
- ◆ Automatic Data Shift and Timer
- ◆ Support CSV and MySQL

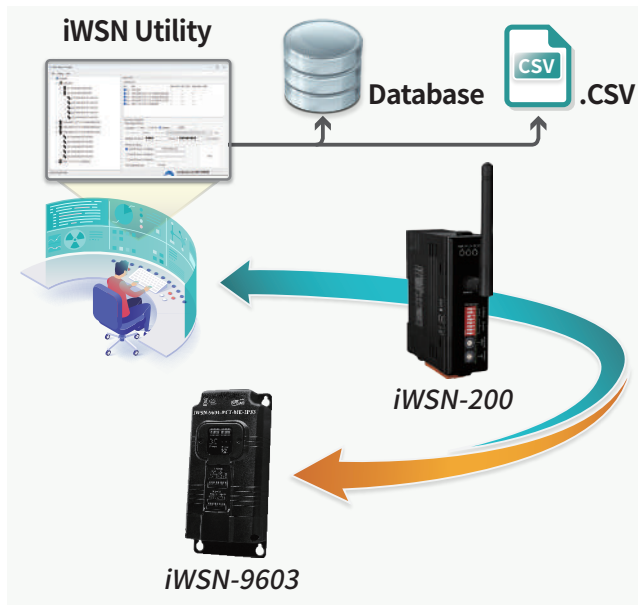

■ Multi-Network Segment Domain

Provides 16 frequency bands and 4 group IDs that can be combined to create up to 64 subdomains, with 31 sensing modules in a single subdomain.

■ Time Stamp for Electricity Refill

- ◆ Built-in real-time clock (RTC)
- ◆ Power Information with Time Stamping
- ◆ Mechanical Difference Analysis and Carbon Footprint Calculation



Minimal wiring design saves time & money

Power supply and measurement share the same circuit, saving wiring costs.

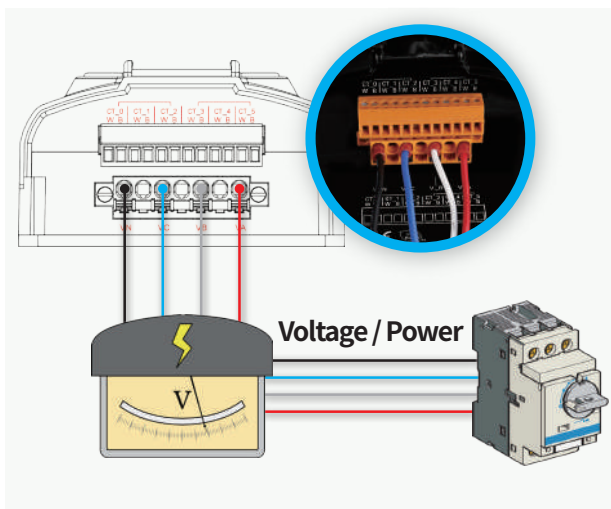

Water-proof Design

iWSN-9603 series modules can be installed on the outside of the control box. The IP33 water-proof design effectively reduces the risk of short-circuiting, leakage, and inadvertent contact caused by exposed contacts during sprinkler firefighting.

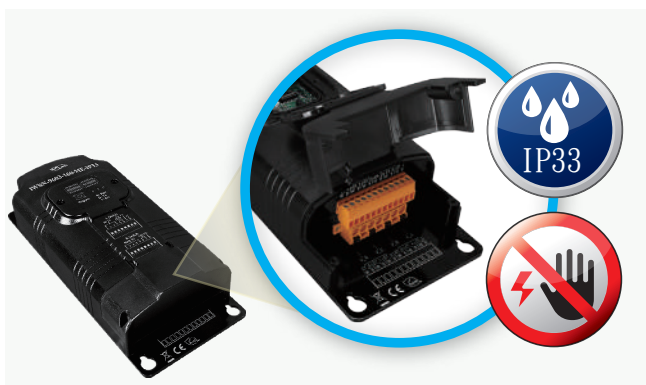

IP33 Protection Design



Water Resistant Material



Protective Case of DIP Switch

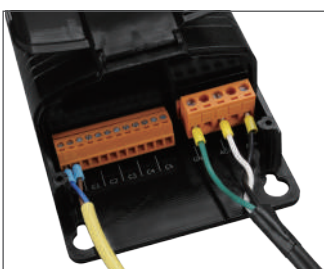

iWSN-9601 Wiring

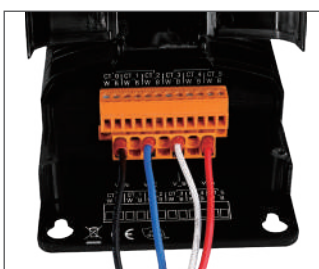

iWSN-9603 Wiring

Multi-Sensor Module

The Data Concentrator can integrate with other iWSN sensing modules to enhance system functionality and application flexibility by expanding the sensing modules.

	AC		4~20 mA
	Temperature Humidity		CO CO2e TVOC
	Thermal Imaging		Vibration
	Emergency SOS		Leak

Various CT/RCT, suitable for thick & thin wire diameter

Open-ended design, depending on the model and measurement range, provides higher accuracy and installation flexibility.

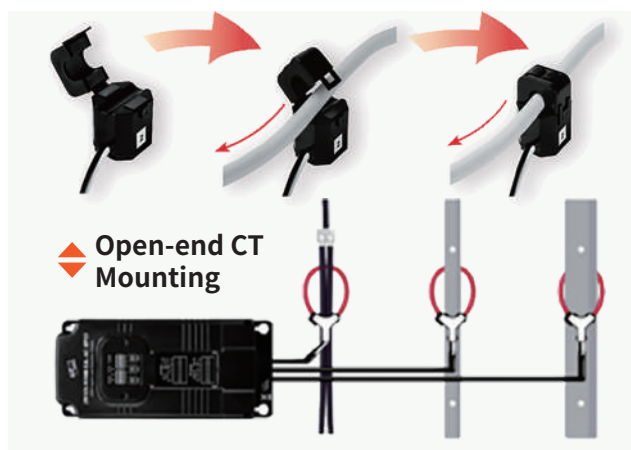

Ch9. Infrared Thermal Temperature Security Monitoring Solution

9.1 Introduction

Temperature sensing can be implemented in a variety of fields such as devices failure analysis in steel factory, high temperature warning in electrical room, or body temperature monitoring in pandemic prevention. The most commonly used in industry is taking measurement through contact devices such as Thermistor, RTD, and TC. However, for those areas not being able to install the contact device, non-contact measurement may be a better choice.

In response to the market and customer requirements, ICP DAS has developed Infrared Thermography Series products based on non-contact temperature measurement technology. This series of products offers advantages including the ability to measure the temperature for a wide range surface temperature distribution and compare them. They can also perform non-contact temperature measurements on food, pharmaceuticals, chemicals, etc. to ensure hygiene. They enable temperature measurement of objects in motion or those are dangerous or inaccessible. In addition, they can measure the surface temperature of fine grain and measure the instantaneous value of the temperature for objects with rapid temperature changes.

9.2 Devices for Infrared Thermal Imaging Temperature Sensing

■ **Electrical Devices:** Loose joints/poor contact, unbalanced load, overload, overheating or other hidden dangers can be found.

■ **Transformer:** It can be found whether there are loose joints, overheated bushings, poor contact (tap changer), overload, unbalanced three-phase load, or poor cooling pipe blockage.

■ **Motor/Generator:** Excessive bearing temperature, unbalanced load, short circuit or open circuit of winding, heating of carbon brushes, slip rings & collector rings, overload & overheating and blockage of cooling pipes, etc. can be found.

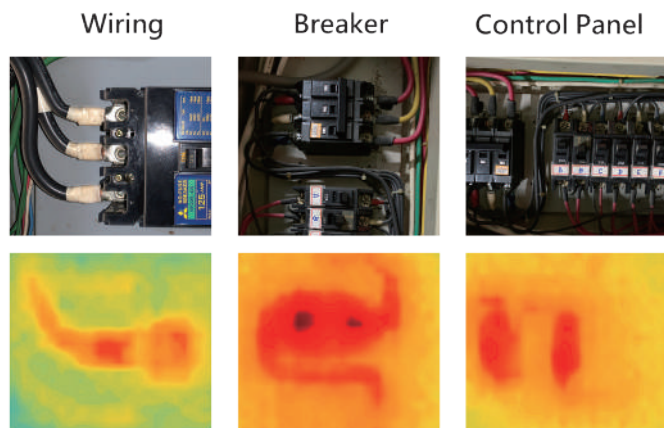

9.3 Contact Thermometry V.S. Non-Contact Thermometry

The advantages of infrared thermometry:

1. Read temperature value of wide range of surface temperature distribution and perform relative comparison.
2. Perform non-contact temperature measurements on food, pharmaceuticals, chemicals, etc. to ensure hygiene.
3. Measure the temperature of objects in motion or objects that are dangerous or inaccessible.
4. Rapidly implement temperature measurement applications in fields where contact-based solutions cannot be deployed.

	Contact	Non-contact
Types	<ul style="list-style-type: none"> • Thermocouple • Thermistor • RTD 	<ul style="list-style-type: none"> • Infrared
Advantage	<ul style="list-style-type: none"> • High precision • Real temperature can be measured 	<ul style="list-style-type: none"> • Can measure moving objects • Wide measurement range • Perform measurements without interfering with the normal operation of the measured objects.
Disadvantage	<ul style="list-style-type: none"> • Measure fixed objects • Measure specific points or small areas • Susceptible to corrosion 	<ul style="list-style-type: none"> • Thermal radiation is susceptible to the environment • Measures surface temperature only

9.4 IR Temperature Measurement Applications

Infrared – Visible temperature, the iSN-81x series adopts the most advanced infrared imaging technology which can detect infrared radiation or thermal energy. It can also generate clear images according to the detected difference in temperature, which is a non-invasive monitoring method to provide real-time temperature monitoring and alarm solutions for industrial safety and quality control of production line.

The iSN-81x-MRTU series is designed as a common Modbus communication interface. With the VPD-170-IRT temperature data concentrator or IIoT edge computing controller developed by ICP DAS, the measured temperature data from the iSN-81x-MRTU series products can be collected and sent to the cloud for data analyzing. In addition, the alarm output is based on the definition of alarm rule settings to reduce the burden of personnel on duty and inspection.

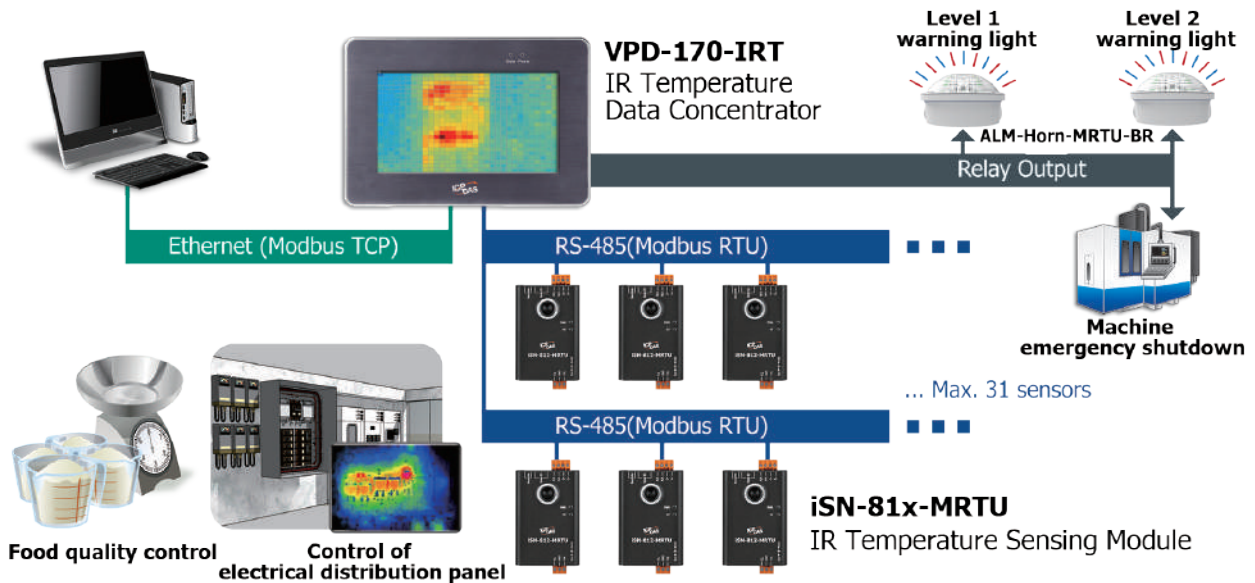

The iSN-81x-MTCP series supports Power over Ethernet (PoE), allowing users to complete power supply and communication by simply connecting to a PoE network switch. The iSN-81x-MTCP supports Modbus TCP, RESTful, and MQTT communication protocols. Through the Modbus TCP protocol, it can be easily integrated into SCADA systems to provide real-time object temperature measurement information. The iSN-81x-MTCP supports sending measurement data to a remote database server for storage using the RESTful method. As an MQTT client, the iSN-81x-MTCP sends measurement data to the broker, and SCADA, management platforms, and IoT systems can easily obtain the iSN-81x-MTCP measurement data by subscribing to the topic. The iSN-81x-MTCP is your reliable partner for equipment monitoring, data analysis, and anomaly detection in industrial environments.

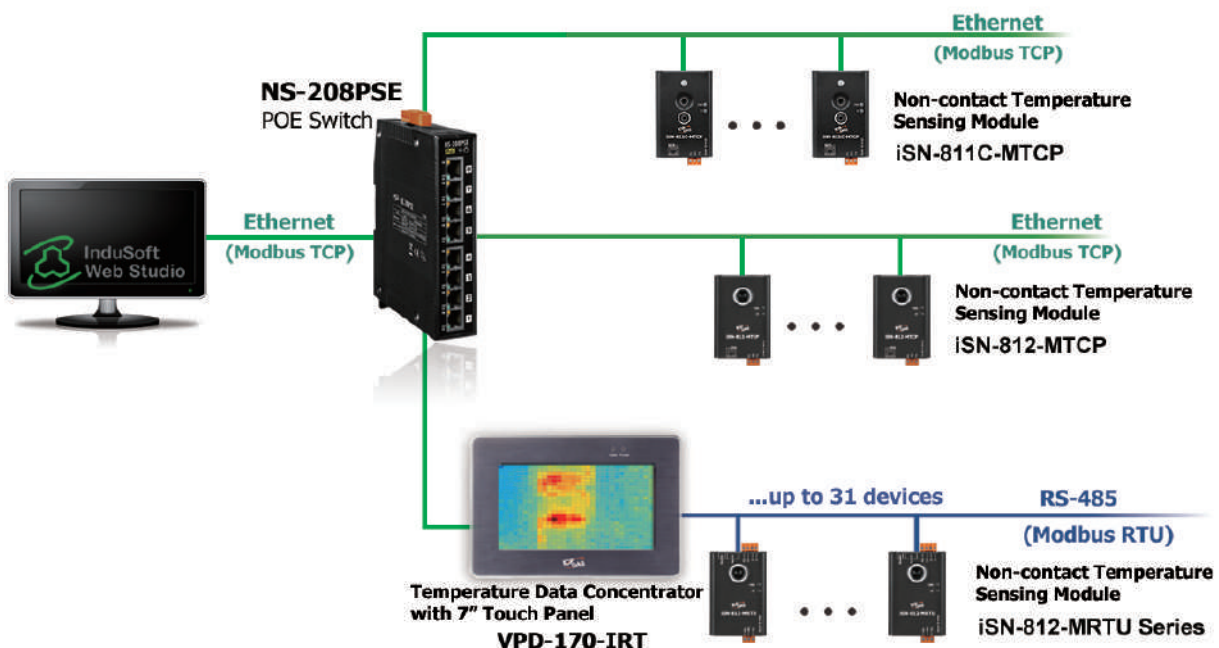

■ **Non-contact, full-surface temperature monitoring**

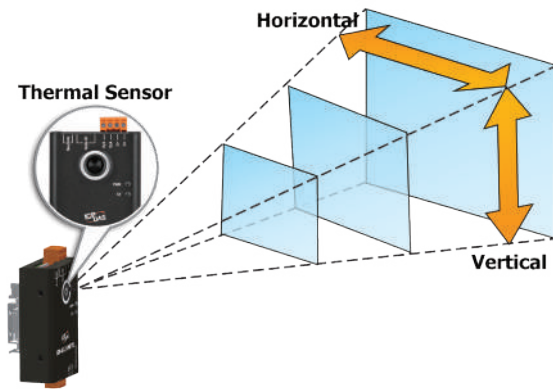

■ **Provide wall mount, magnetic & universal mount installation, etc.**

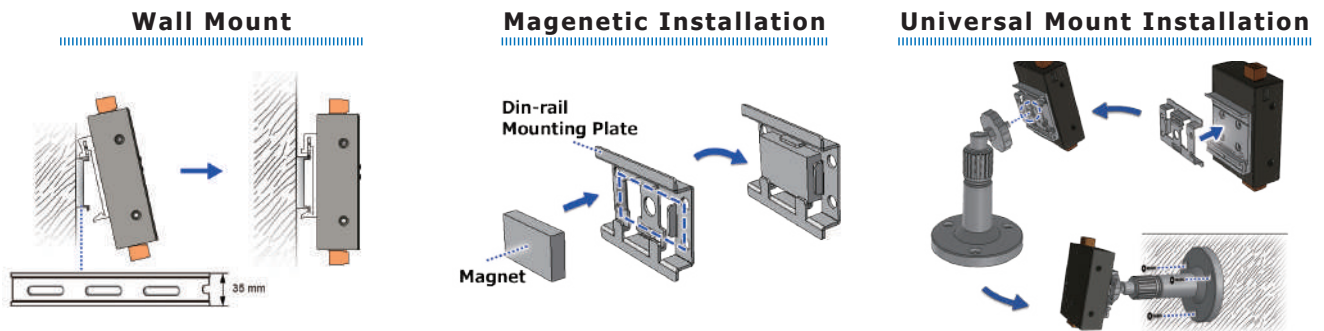

9.5 Infrared Thermal Imaging Temperature Sensing Application

Safety Monitoring System of Distribution Cabinet

Due to various faults of the machine (overload, overcurrent, on-site dust accumulation, etc.), the temperature of the switchboard will rise, resulting in the deterioration of the insulation on the line and causing an industrial safety crisis. VPD-170-IRT temperature concentrator series and iSN-81x-MRTU temperature sensor series meet the long-term monitoring and alarm requirements of power transmission and distribution cabinets, and monitor and record the temperature of lines and transformers in the panel. The system also simultaneously extends the monitoring of power and water leakage status, realize all-over safety monitoring, send alarms in case of over-temperature, abnormal power consumption, or water leakage to avoid major losses caused by machine failures, and further evaluate whether it is line aging or equipment overload to facilitate maintenance and replacement.

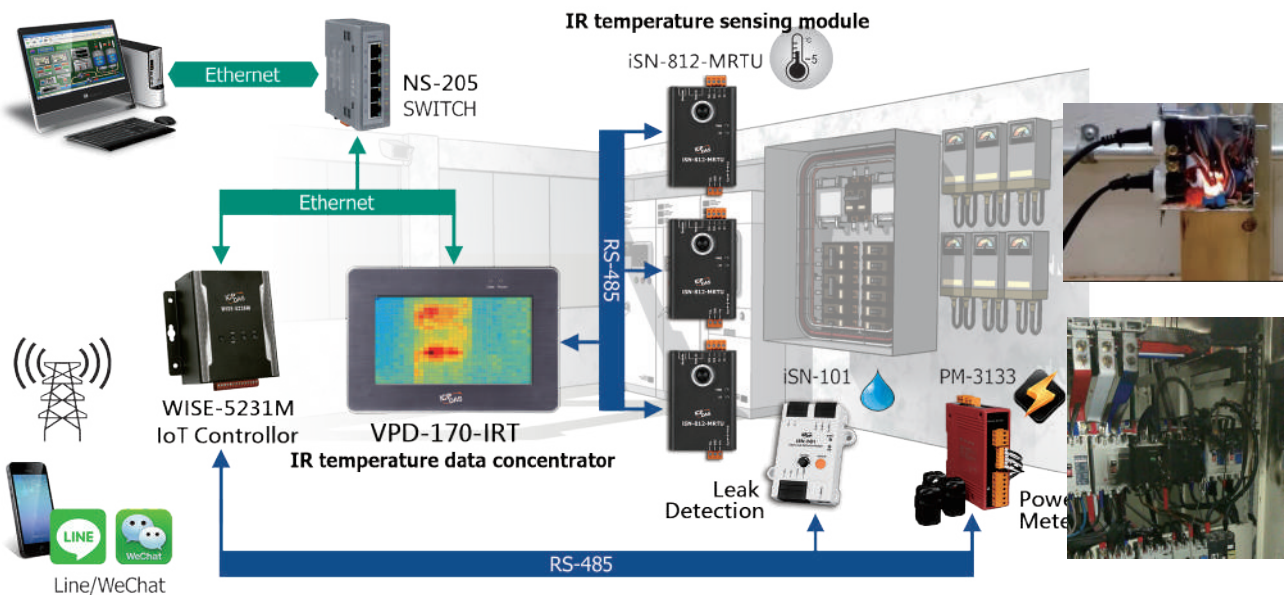

9.6 VPD-170-IRT Temperature Data Concentrator

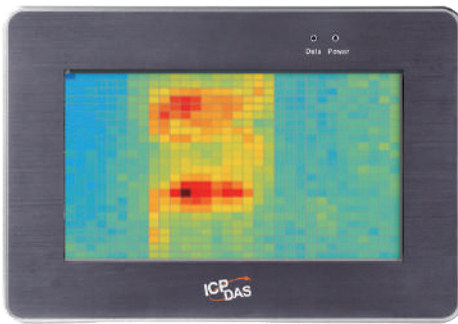

VPD-170-IRT

Features

- High-resolution color touch screen
- Front Panel: IP6S Waterproof
- Temperature threshold detection function
- Thermography available
- Supports up to 31 iSN-81x-MRTU
- Support Modbus TCP/RTU protocols

VPD-170-IRT supports 8 Modbus TCP connections, allowing remote monitoring hosts to connect to VPD-170-IRT via Ethernet and access temperature data of multiple iSN-81x-MRTUs at one time. Users can set various functions of iSN-81x-MRTU and VPD-170-IRT from the touch screen of VPD-170-IRT, and can also immediately see the temperature and thermal image of the measured object. Through the convenient connection and communication capabilities between the VPD-170-IRT temperature data concentrator and the Ethernet network, users can quickly establish a remote monitoring system and conduct centralized management of temperature data.

Software

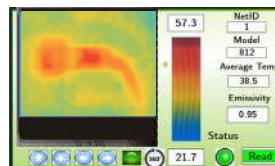

- Display the connection status and temperature data of each thermal sensing module.
- Quickly search and set the thermal sensing module: high temperature alarm, warning threshold type, temperature range and average value display.
- Simultaneous connection of up to 31 modules via software.

Specifications

Model	VPD-170-IRT
Real Time Clock	YES
Display Type	7" TFT
Rubber Keypad	N/A
Ethernet	1 (10/100 Base-TX)
COM Ports	2 x RS-232 (3-pin) / RS-485 including Self-Tuner
Protocol	Modbus RTU / Modbus TCP
Relay Out (Form A)	Signal Relay(Form A): 9 CH (2A@30VDC, 0.24A@220VDC, 0.25A@250VAC)
Power	Terminal Block: 12 to 48 VDC / PoE : IEEE 802.3af, Class1 (48 V)
Dimensions (mm)	217 x 153 x 33 (W x H x D)
Humidity	10 to 90% RH, non-condensing
Operating Temperature	-10 to + 60° C

9.7 iSN-81x-MRTU/MTCP Temperature Sensing Module



iSN-811-MRTU
iSN-812-MRTU
iSN-811C-MTCP
iSN-812-MTCP

Features

- Non-contact temperature measurement
- iSN-81x-MRTU supports Modbus RTU
- iSN-81x-MTCP supports Modbus TCP, RESTful, and MQTT communication protocols
- iSN-81x-MTCP supports web configuration and monitoring interface
- Temperature threshold detection function
- Offers Wall-mount, magnetic and universal joint for installation

iSN-81x-MRTU / iSN-81x-MTCP series is sensing module that designed specifically for non-contact temperature measurement. The module provides a variety of temperature pixels and temperature threshold detection functions to meet various temperature measurement needs. It also provides Modbus RTU/TCP protocol that users can put it into SCADA system very easily.

Specifications

Model	iSN-811-MRTU	iSN-812-MRTU	iSN-811C-MTCP	iSN-812-MTCP
COM Ports	1 x RS-485 (115200 bps Max.)		1 x RJ-45, 10/100Base-TX PoE (IEEE 802.3af, Class 1)	
Protocol	Modbus RTU		Modbus TCP/RESTful/ MQTT	
Temp. Range	-20 to +250°C	-40 to +300°C	-20 to +250°C	-40 to +300°C
Temp. Accuracy	±5°C Max.			
Temp. Resolution	0.1°C			
Pixels	64 (8x8)	768 (32x24)	64 (8x8)	768 (32x24)
FOV	X: 60° / D : S =1 : 1.15 Y: 60° / D : S =1 : 1.15	X: 110° / D : S =1 : 2.86 Y: 75° / D : S =1 : 1.53	X: 60° / D : S =1 : 1.15 Y: 60° / D : S =1 : 1.15	X: 110° / D : S =1 : 2.86 Y: 75° / D : S =1 : 1.53
Type	IR			
Effective Distance	1 M			
Image Sensor	-		CMOS	-
Resolution	-		QVGA (320x240)	-
Input Range	+10 to +30 VDC			
Consumption	1.5W			
Dimensions (mm)	52 x 94 x 33 (W x H x D)		52 x 86 x 34 (W x H x D)	
Installation	Wall-mounting or magnetic mounting, gimbal mounting			
Humidity	10% to 95% RH, non-condensing			
Operating Temp.	-10 to + 70° C			

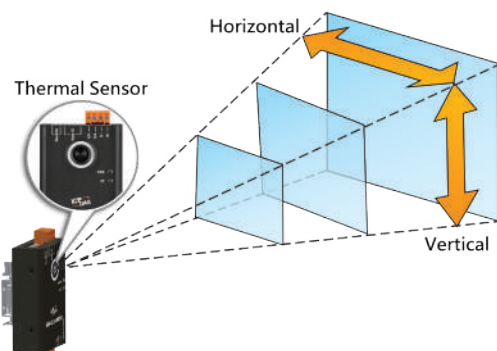

Model	Sensing Range/ Object Distance 25 cm		FOV	
	X axis	Y axis	X axis	Y axis
iSN-811-MRTU	29 cm	29 cm	60°	60°
iSN-811C-MTCP				
iSN-812-MRTU	71 cm	38 cm	110°	75°
iSN-812-MTCP				

Ch10. Portable Power Monitoring Suitcase



PPMS-133D-RCT2000P

Features

- True RMS Power Measurements
- Energy Analysis for 3P4W, 3P3W, 1P3W, 1P2W
- Voltage Measurements up to 500 V
- Current Measurements up to 2000 A
- Harmonic data capture (up to 31th order)
- Provide 7" Touch Panel for On-Site operations
- Support SNMP Protocol
- Temperature and Humidity Data Logger

Introduction

Portable Power Management Suitcase can measuring single to three-phase lines with a high degree of precision and accuracy. The PPMS-133D-RCT2000P Rogowski Coil CT power meters designed to measure demand and harmonics, which are important for energy management, as well as basic electrical parameters such as voltage, current, power, power factor, and integrated power (watthours).

PPMS-133D-RCT2000P is equipped with built-in Web Server that allows direct connections via browsers to the PPMS-133D-RCT2000P for viewing power data and setting up the system parameters.

PPMS-133D-RCT2000P allows connect to SCADA software to get real-time power data.



Applications

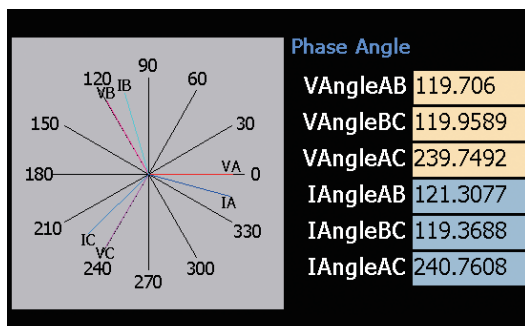

▲Phase angle detector

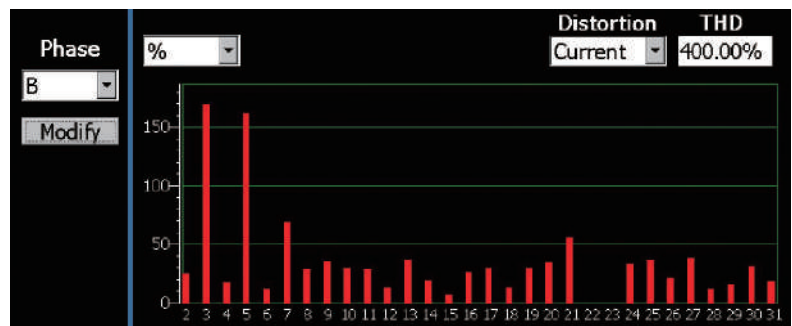

▲Harmonic data capture

Ordering Information

PPMS-133D-RCT2000P	Portable Power Monitoring Suitcase, 2000A Rogowski Coil CT (Inside diameter 105 mm; wire lead 4 m)
--------------------	--

Ch11. RPS-4M Redundant Power Supply

11.1 Overview

With the continuous upgrading and innovation of the industry, the applications of smart manufacturing, smart transportation, and smart medical care all require stable and reliable DC power supplies, especially devices such as edge computing, computer rooms, and AI analysis. This type of intelligent system requires a stable power supply to maintain the normal operation of the equipment in order to realize the vision of smart upgrades. If there is a problem with the power supply, various equipment will stop operating, causing great losses.

In response to the requirements of lots of digital DC power supplies in the industry, the RPS series of redundant power supply, which not only adopts the N+1 parallel-connection and load-sharing technology to implement power redundancy, but also adds communication functions to enable that information of power supply can be monitored in real time. Through the communication functions, user can monitor the working status of the power supply of the whole factory in the monitoring center. When the power module is abnormal, it can be found and dealt with in real time. There is no need to send people to inspect and ensure that the power supply is safe. In particular, the equipment in some important industries such as finance, medical treatment and power plants needs stable power supplies to ensure that the equipment keeps working.

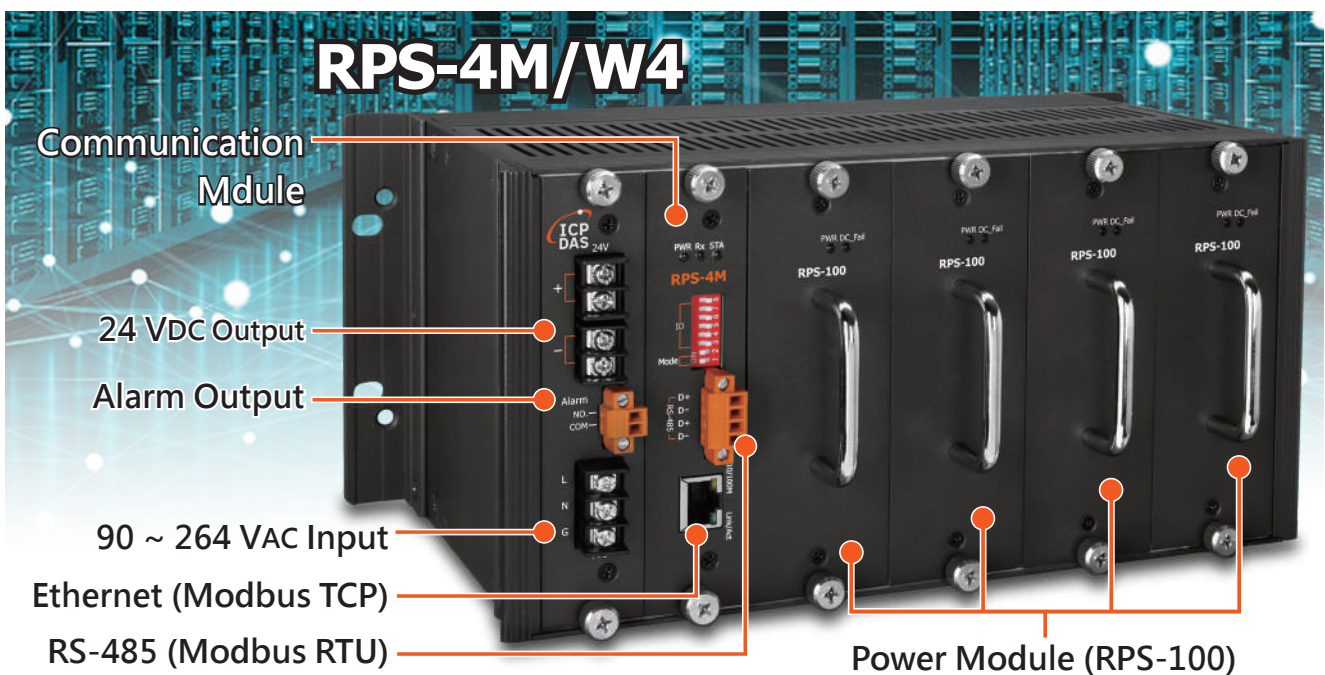

11.2 Features

1. Convert 90 to 264 VAC to 24 VDC
2. Each slot can insert a 100W power module, support hot swapping and failure alarm (relay output) functions
3. Design for N+1 Redundant, provide up to 300W redundant power supply
4. Built-in load balancing and power diagnosis functions
5. Detect temperature/current load/failure status (relay output)/used time of Power module
6. Support Modbus RTU/TCP Protocol. The HMI can obtain information about the power module in real-time for fault diagnosis and preventive maintenance

11.3 Traditional V.S. RPS-4M Redundant Power Supply

	Traditional Power Supply	RPS-4M
Damage Replacement	Power off to manually pull out the replacement, affecting the system operation	Damaged power modules can be directly hot-swapped and replaced
Power Supply	Fixed	Can be expanded according to system size
Load Balancing	Requires an external load balancing module	Built-in load balancing function
Communication Port	N/A	Support Modbus RTU/TCP Protocol
Current Temperature Measurement	N/A	Can measure load current and temperature of module

11.4 Redundant Power Supply Monitoring System

The RPS series power supply can form a complete backup system with various redundant monitoring system solutions from ICP DAS. Including I/O redundancy (data acquisition), controller redundancy (program control), Ethernet Ring communication redundancy (ring network communication) and HMI monitoring redundancy (information record display).

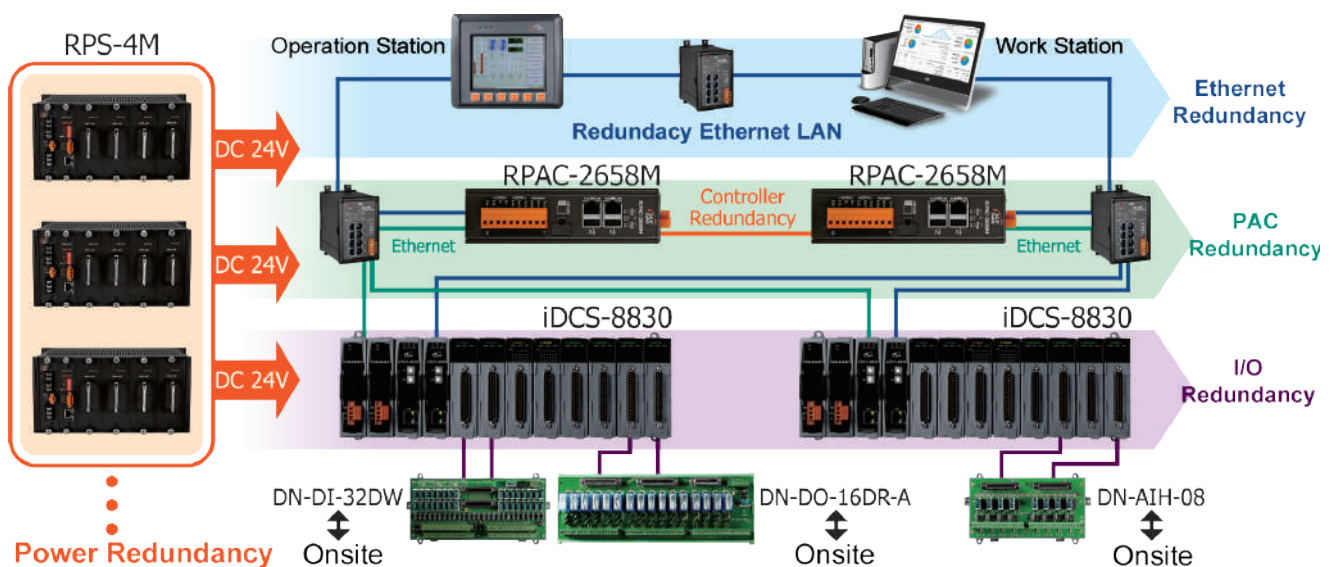

Ordering Information

RPS-4M/W2	CR	4-slot Industrial Redundant Power Supply. Includes two RPS-100 modules (RoHs)
RPS-4M/W4	CR	4-slot Industrial Redundant Power Supply. Includes four RPS-100 modules (RoHs)



- IIoT 1
Software . Controller/Server**
- Cloud Management Software: IoTStar
 - SCADA System Software: AVEVA Edge
 - Condition Monitoring Solution: ExoWISE
 - Edge Controller WISE Series
 - Communication Server: UA Series
 - MQTT Communication Server: BRK Series



- IIoT 2
Access Control Security/
Factory Automation**
- WISE Surveillance Solution
 - IP Camera iCAM Series
 - Smart Access Control
 - IIoT and Smart Phone Integration
 - MQTT I/O Module MQ Series
 - Stack Light Monitoring Module
 - Emergency Voice/Visual Alert Module
 - Industrial LED Message Display
 - Bluetooth LE Gauge Master
 - Temperature Data Logger
 - Signal Conditioning Modules
 - No-touch Infrared Sensor Switch



- IIoT 3
Environmental Monitoring/
Mini Weather Station**
- Smart Environmental Monitoring: CL Series
 - Air Box: DL Series
 - Mini Weather StationMotion: DLW Series
 - Detector: PIR Series
 - Industrial Sensor Network Detection: iSN Series
 - Wireless Environmental Solution: iWSN/iXN/iSOS Series



- IoT Cloud Software -
IoTstar 2025**
- Introduction
 - Features
 - Applications
 - Controller Supported List
 - Other Information



- WISE
Intelligent IIoT Edge
Controller & I/O Module**
- WISE IIoT Edge Controller I/O Module
 - Cloud Management
 - WISE Applications
 - IIoT Edge Controller
 - Intelligent I/O Module
 - Intelligent Surveillance Solution
 - Smart Phone Integration Solution
 - Condition Monitoring Solution



- Smart Building,
Smart Home Automation**
- Video Intercom & Access Control
 - Touch HMI - TouchPAD Series
 - Smart Lighting Control
 - Energy Saving - PM/PMC Series
 - Environmental - DL/CL Series
 - Motion Detector - PIR Series
 - Wi-Fi Wireless - WF Series
 - Infrared Wireless - IR Series
 - ZigBee Wireless - ZT Series
 - IIoT Server & Concentrator
 - LED Display - iKAN Series



- PC-based I/O Boards**
- PCI Express Bus Data Acquisition Boards
 - PCI Bus Data Acquisition Boards
 - ISA Bus Data Acquisition Boards



- TouchPAD HMI Solutions**
- Introduction
 - TPD/VPD Products Series
 - Video Intercom & Access Control Series
 - TPD/VPD Application

