

IN485MIT001A000 User Manual

Mitsubishi Electric Ecodan Air-to-Water Units
to BACnet MS/TP and Modbus RTU

USER MANUAL
Version 1.0.0
Publication date 2025-06-30

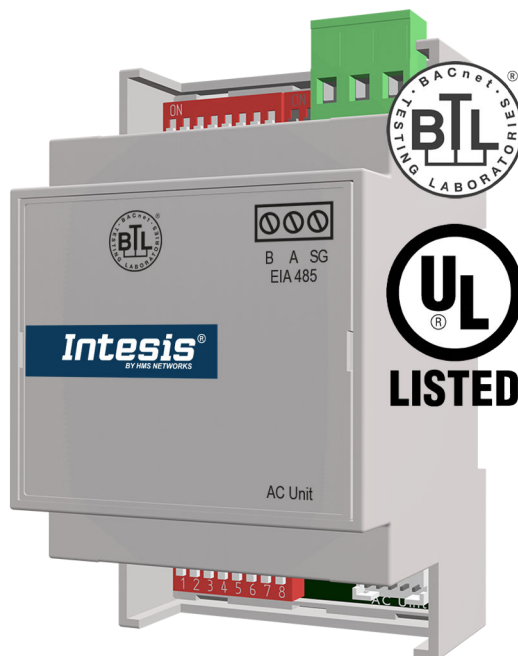

Copyright © 2025 Intesis

Disclaimer

The information in this document is for informational purposes only. Please inform HMS Networks of any inaccuracies or omissions found in this document. HMS Networks disclaims any responsibility or liability for any errors that may appear in this document.

HMS Networks reserves the right to modify its products in line with its policy of continuous product development. The information in this document shall therefore not be construed as a commitment on the part of HMS Networks and is subject to change without notice. HMS Networks makes no commitment to update or keep current the information in this document.

The data, examples and illustrations found in this document are included for illustrative purposes and are only intended to help improve understanding of the functionality and handling of the product. In view of the wide range of possible applications of the product, and because of the many variables and requirements associated with any particular implementation, HMS Networks cannot assume responsibility or liability for actual use based on the data, examples or illustrations included in this document nor for any damages incurred during installation of the product. Those responsible for the use of the product must acquire sufficient knowledge in order to ensure that the product is used correctly in their specific application and that the application meets all performance and safety requirements including any applicable laws, regulations, codes and standards. Further, HMS Networks will under no circumstances assume liability or responsibility for any problems that may arise as a result from the use of undocumented features or functional side effects found outside the documented scope of the product. The effects caused by any direct or indirect use of such aspects of the product are undefined and may include e.g. compatibility issues and stability issues.

Table of Contents

1. Description and Order Codes	1
2. General Information	2
2.1. Intended Use of the User Manual	2
2.2. General Safety Information	2
2.3. Admonition Messages and Symbols	3
3. Quickstart Guide for the IN485MIT001A000 Gateway	4
4. Overview	5
4.1. Inside the Package	6
4.2. Main Features	6
4.3. Gateway Capacity	6
4.4. General Functionality	6
5. Hardware	7
5.1. DIP Switches	7
5.2. Mounting	9
5.3. Connection Procedure	10
5.4. LED Indicators	12
5.5. Technical Specifications	13
5.6. Dimensions	13
6. Restore the Factory Settings	14
7. BACnet Specifications	15
7.1. Supported Object Types	15
7.2. Gateway Objects	15
7.3. General Objects	16
7.4. Zones Objects	17
7.5. Zone 1 Objects	17
7.6. Zone 2 Objects	19
7.7. Domestic Hot Water Objects	22
7.8. Outdoor Unit Temperature Objects	23
7.9. Extra Signals for the BACnet Configuration	23
8. Modbus Specifications	26
8.1. Implemented Modbus Functions	26
8.1.1. Modbus Physical Layer	26
8.2. Modbus Registers	26
8.2.1. Gateway Registers	27
8.2.2. General Registers	27
8.2.3. Zones Registers	29
8.2.4. Zone 1 Registers	29
8.2.5. Zone 2 Registers	31
8.2.6. Domestic Hot Water Registers	33
8.2.7. Outdoor Unit Temperature Registers	34
8.2.8. Extra Signals for the Modbus Configuration	35
9. Virtual Temperature	37
10. Error Codes	40
10.1. Gateway Error Codes	40

10.2. Mitsubishi Electric Ecodan Error Codes 40

1. Description and Order Codes

BACnet MS/TP and Modbus RTU gateway for Mitsubishi Electric Ecodan air-to-water units.

Compatible with Ecodan air-to-water units commercialized by Mitsubishi Electric.

Use the compatibility tool to get a complete list of compatible units: <https://compatibility.intesis.com/>

ORDER CODE	LEGACY ORDER CODE
IN485MIT001A000	-

2. General Information

2.1. Intended Use of the User Manual

This manual contains the main features of this gateway and the instructions for its appropriate installation, configuration, and operation.

Any person who installs, configures, or operates this gateway or any associated equipment should be aware of this manual's contents.

Keep this manual for future reference during the installation, configuration, and operation.

2.2. General Safety Information



IMPORTANT

Follow these instructions carefully. Improper work may seriously harm your health and damage the gateway and/or any other equipment connected to it.

Only technical personnel, following these instructions and the country legislation for installing electrical equipment, can install and manipulate this gateway.

Install this gateway indoors, in a restricted access location, avoiding exposure to direct solar radiation, water, high relative humidity, or dust.

Preferably, mount this gateway on a DIN rail inside a grounded metallic cabinet, following the instructions in this manual.

If mounting on a wall, firmly fix this gateway on a non-vibrating surface, following the instructions in this manual.

Connect this gateway only to networks without routing to the outside plant.

All communication ports are considered for indoor use and must only be connected to SELV circuits.

Disconnect all systems from power before manipulating and connecting them to the gateway.

Respect the expected polarity of power and communication cables when connecting them to the gateway.

Take the necessary antistatic precautions before manipulating the gateway to avoid electrostatic discharges.

Safety instructions in other languages can be found [here](#).

2.3. Admonition Messages and Symbols



CAUTION

Instruction that must be followed to avoid a potentially hazardous situation that, if not avoided, could result in minor or moderate injury.



IMPORTANT

Instruction that must be followed to avoid a risk of reduced functionality and/or damage to the equipment or to avoid a network security risk.



NOTE

Additional information which may facilitate installation and/or operation.



TIP

Helpful advice and suggestions.



NOTICE

Remarkable Information.

3. Quickstart Guide for the IN485MIT001A000 Gateway



IMPORTANT

Disconnect all systems from power before connecting them to the gateway.

1. Configure the gateway using the built-in DIP switches. See details in [DIP Switches \(page 7\)](#).
2. Mount the gateway in the desired installation site. This gateway can be mounted over a DIN rail or a wall. See details in [Mounting \(page 9\)](#).



NOTE

DIN rail mounting inside a grounded cabinet or metal enclosure is recommended.

3. Connect the gateway to the BACnet MS/TP or Modbus RTU network via its EIA-485 port.
4. Connect the gateway to the Ecodan unit using the cable supplied with the product. See details in [Connection Procedure \(page 10\)](#).
5. Check the communication performance between the BACnet/Modbus bus, the gateway, and the Mitsubishi Electric Ecodan unit through the gateway's LED indicators. See details in [LED Indicators \(page 12\)](#).
6. The Intesis gateway is ready to be used in your system.

4. Overview



NOTE

You can set the IN485MIT001A000 as a BACnet MS/TP or a Modbus RTU server gateway using the SW1-5 (DIP switch 1, position 5). See [DIP Switches \(page 7\)](#).

Figure 1. Integration of Mitsubishi Electric Ecodan units into a BACnet MS/TP installation using the Intesis IN485MIT001A000 gateway

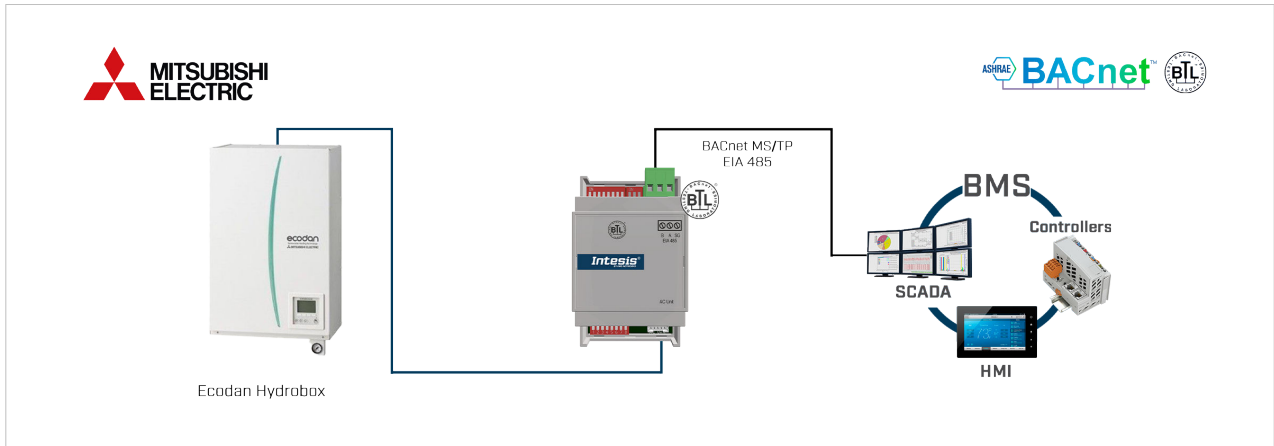
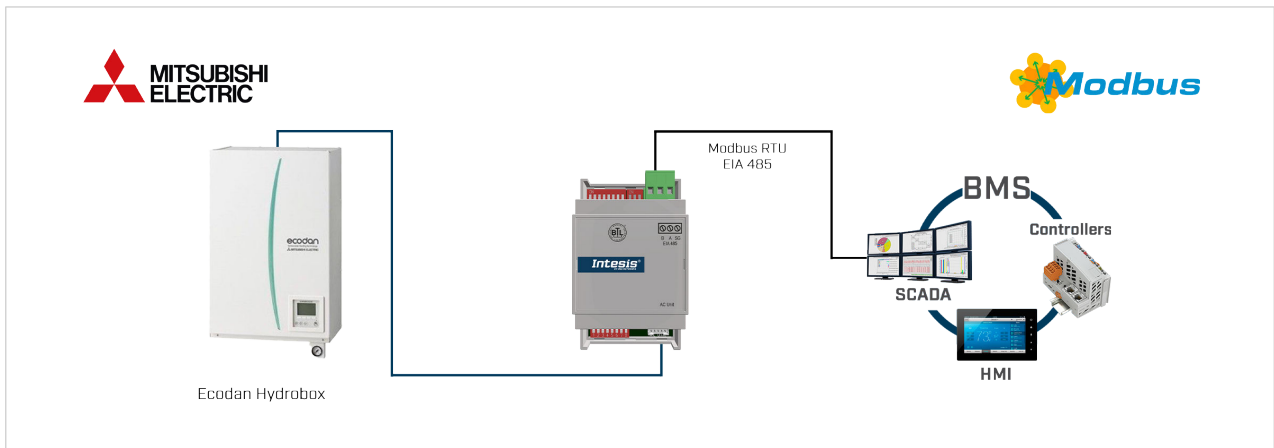

Figure 2. Integration of Mitsubishi Electric Ecodan units into a Modbus installation using the Intesis IN485MIT001A000 gateway



NOTE

This document assumes that the user is familiar with BACnet, Modbus, and Mitsubishi Electric air-to-water heat pump technologies and their technical terms.

4.1. Inside the Package

Items included:

- Intesis IN485MIT001A000 gateway
- [Installation guide](#)
- Ecodan unit connection cable

4.2. Main Features

- Supports BACnet MS/TP and Modbus RTU.
- Configuration with onboard DIP switches.
- Quick and easy installation: Set the DIP switches, plug, and play.
- External power supply not required.
- Simultaneous control of the Ecodan unit via both the remote controller and the BMS (BACnet MS/TP or Modbus RTU).
- Reduced dimensions (HxWxD): 93 x 53 x 58 mm / 3.7 x 2.1 x 2.3".
- Mountable on DIN rail or wall.
- Compatibility with the principal Ecodan system features, including simultaneous control of domestic hot water (DHW) and two climate zones.
- More than 100 communication signals implemented by default that ensure monitoring and control over the main functions of the Ecodan unit: error monitoring, leak detection, running hours counter, temperature limits for DHW and climate, monitoring of compressor and circulation pump operation, and many more.
- Significant reduction of the HVAC system energy consumption.
- Three-year warranty.

4.3. Gateway Capacity

This Intesis gateway can integrate one single Mitsubishi Electric Ecodan air-to-water unit.

4.4. General Functionality

With this Intesis IN485MIT001A000 gateway, you can easily integrate Mitsubishi Electric Ecodan air-to-water units into a system based on BACnet MS/TP or Modbus RTU. To do so, the gateway acts as a server device of the installation itself, accessing the Ecodan unit signals.

The gateway is continuously polling the Ecodan unit, storing in its memory the current status of signals and serving this data to the control system when requested. The gateway also sends the requested commands from the control system to the unit.

A wide range of signals can be controlled and monitored, including general signals, zone signals, domestic hot water signals, and more.

The configuration of the gateway is carried out in a fast and straightforward manner via DIP switches.

5. Hardware

5.1. DIP Switches

All configuration parameters of the gateway are set exclusively using its DIP switches, as detailed in the following tables. No software interface or external configuration tool is required.



IMPORTANT

Ensure the gateway is powered off¹ before adjusting the DIP switches to avoid configuration errors or hardware damage.

¹ Remember that the IN485MIT001A000 gateway is powered exclusively by the Ecodan unit.

The gateway includes three DIP switches: SW1 (8 switches) at the bottom and SW2 (8 switches) and SW3 (3 switches) at the top.

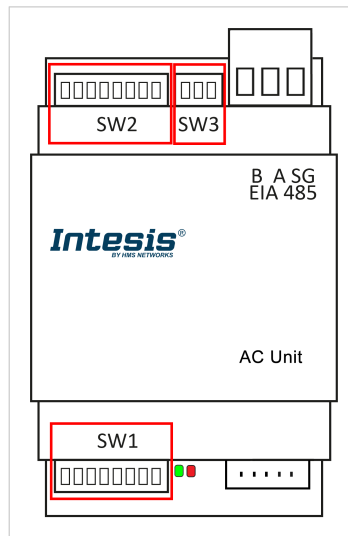

Table 1. **SW1** (P1, P4): Not used; (P5): Control system selection; (P6 to P8): BACnet MS/TP or Modbus RTU baudrate

Position								Description	
1	2	3	4	5	6	7	8	BACnet	Modbus
X	X	X	X	OFF	X	X	X	BACnet MS/TP enabled (default)	
X	X	X	X	ON	X	X	X	Modbus RTU enabled	
X	X	X	X	X	OFF	OFF	OFF	Autobaudrate (default)	2400 bps (default)
X	X	X	X	X	ON	OFF	OFF	9600 bps	4800 bps
X	X	X	X	X	OFF	ON	OFF	19200 bps	9600 bps
X	X	X	X	X	ON	ON	OFF	38400 bps	19200 bps
X	X	X	X	X	OFF	OFF	ON	57600 bps	38400 bps
X	X	X	X	X	ON	OFF	ON	76800 bps	57600 bps
X	X	X	X	X	OFF	ON	ON	115200 bps	76800 bps
X	X	X	X	X	ON	ON	ON	Autobaudrate	115200 bps

Table 2. **SW2 (BACnet MS/TP)** (P1 to P7): BACnet MS/TP MAC address; (P8): Temperature unit (°C/°F)

Position								BACnet address	Description
1	2	3	4	5	6	7	8		
OFF	OFF	OFF	OFF	OFF	OFF	OFF	X	0	-
ON	OFF	OFF	OFF	OFF	OFF	OFF	X	1	-
OFF	ON	OFF	OFF	OFF	OFF	OFF	X	2	-
ON	ON	OFF	OFF	OFF	OFF	OFF	X	3	-
...								...	-
ON	OFF	ON	ON	ON	ON	ON	X	125	-
OFF	ON	ON	ON	ON	ON	ON	X	126	-
ON	ON	ON	ON	ON	ON	ON	X	127	-
X	X	X	X	X	X	X	OFF	-	Temp. in °C (default)
X	X	X	X	X	X	X	ON	-	Temp. in °F

Table 3. **SW2 (Modbus RTU)** (P1 to P6): Modbus server address; (P7): Degree decimals setting; (P8): Temperature unit (°C/°F)

Position								Modbus address	Description
1	2	3	4	5	6	7	8		
ON	OFF	OFF	OFF	OFF	OFF	X	X	1	-
OFF	ON	OFF	OFF	OFF	OFF	X	X	2	-
ON	ON	OFF	OFF	OFF	OFF	X	X	3	-
...								...	-
ON	OFF	ON	ON	ON	ON	X	X	61	-
OFF	ON	ON	ON	ON	ON	X	X	62	-
ON	ON	ON	ON	ON	ON	X	X	63	-
X	X	X	X	X	X	OFF	X	-	Temp. in degrees x1 (default)
X	X	X	X	X	X	ON	X	-	Temp. in degrees x10. Example: 19.2°=192
X	X	X	X	X	X	X	OFF	-	Temp. in °C (default)
X	X	X	X	X	X	X	ON	-	Temp. in °F

Table 4. **SW3** (P1 to P3): BACnet/Modbus polarization and termination resistor

Position			Description
1	2	3	
OFF	X	X	EIA-485 bus without termination resistor. The gateway is not at one end of the EIA-485 bus (default value)
ON	X	X	120 Ω termination resistor active. The gateway is at one end of the EIA-485 bus
X	OFF	OFF	No bus polarization (default value)
X	ON	ON	Bus polarization active



IMPORTANT

Observe the **ON** indicator on each DIP switch as a reference.

The DIP switches configuration will only take effect after repowering the gateway.

5.2. Mounting

Mount the gateway over a DIN rail or over a wall.



IMPORTANT

Before mounting, please ensure that the chosen installation place preserves the gateway from direct solar radiation, water, high relative humidity, or dust.



IMPORTANT

Leave enough clear space to wire the gateway easily and for the subsequent manipulation of elements such as connectors, DIP switches, etc.



IMPORTANT

Do not mount the gateway in air-handling units or conducts.



NOTE

DIN rail mounting inside a grounded metallic cabinet is recommended.

DIN rail mounting

1. Fit the gateway's top-side clip in the upper edge of the DIN rail.
2. Press the low side of the gateway gently to lock it in the DIN rail.
3. Make sure the gateway is firmly fixed.

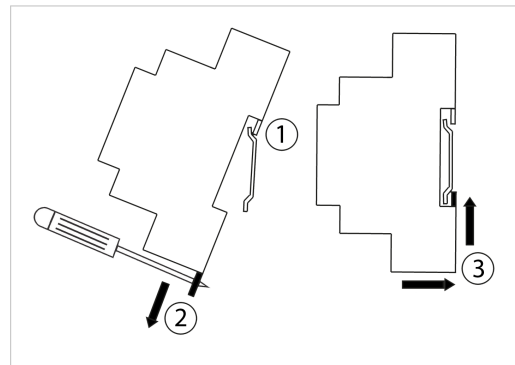

NOTE

For some DIN rails, to complete step 2, you may need a small screwdriver or similar to pull the bottom clip down.

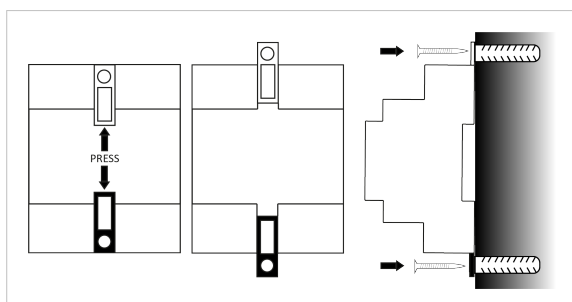

Wall mounting

1. Press the rear panel clips outwards until you hear a *click*.
2. Use the clip holes to screw the gateway to the wall.
3. Make sure the gateway is firmly fixed.

5.3. Connection Procedure



CAUTION

Disconnect all systems from power before connecting them to the gateway.



IMPORTANT

Keep communication cables as far away as possible from power and ground cables. Never bundle them together.



NOTE

Mount the gateway in the desired place before wiring it.

Figure 3. Wiring diagram

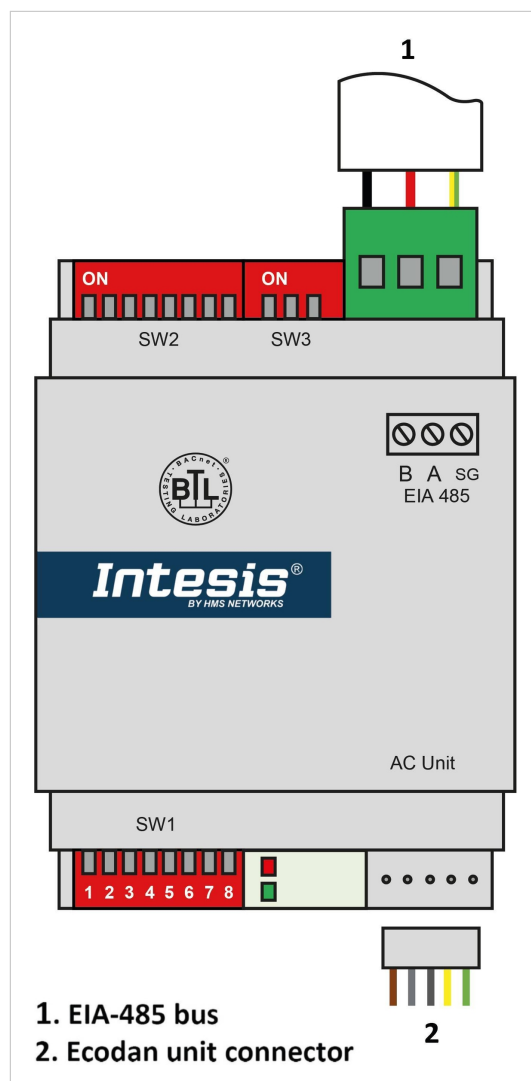

Connecting the gateway to the Ecodan unit

1. Use the supplied cable to connect the Ecodan unit and the gateway:



IMPORTANT

This cable is 1.50 m (4.9 feet) long. Its modification in length may affect the correct operation of the gateway.

- a. **Ecodan unit connection:** Plug the end connector, the one on the longest unsheathed part of the cable, into the socket CN105 of the Ecodan unit control board.
- b. **Gateway connection:** Plug the other end connector, the one on the shortest unsheathed part of the cable, into the gateway's socket labeled as **AC Unit**.

Connecting the gateway to the BACnet MS/TP or Modbus RTU bus

2. Connect the BACnet MS/TP or Modbus RTU bus to the EIA-485 port of the gateway.



IMPORTANT

Observe polarity: B-, A+, and SG for signal ground.



IMPORTANT

- EIA-485 bus doesn't allow loop or star topologies.
- Maximum length for the EIA-485 bus is 1200 meters (4000 feet).



EIA-485 BUS. TERMINATION RESISTORS AND FAIL-SAFE BIASING MECHANISM

The EIA-485 bus requires a 120Ω termination resistor at each end of the bus to avoid signal reflections.

In order to prevent fail status detections by the receivers, which are "listening" to the bus, a fail-safe biasing mechanism is required when all the transmitters' outputs are in three-state (high impedance). This mechanism provides a safe status (a correct voltage level) in the bus when all the transmitters' outputs are in three-state.

The IN485MIT001A000 gateway includes an on-board terminator resistor of 120Ω that can be connected to the EIA-485 bus by using DIP switch SW3.

- **SW3, Position 1:**

ON: 120 Ω termination active.

OFF: 120 Ω termination inactive (default position).

Some BACnet MS/TP / Modbus RTU EIA-485 Master devices can provide also internal 120Ω terminator resistor and/or fail-safe biasing. Consult the technical documentation of the Master device connected to the EIA-485 network in each case.

If the termination resistor is enabled and you install the gateway at one of the ends of the bus, do not install an additional termination resistor at that end.

To know more, refer to the document [Polarity Issues in RS485 Networks](#).

3. Reconnect all systems to power.

5.4. LED Indicators

There are two LEDs at the lower side of the gateway, between the DIP switch block SW1 and the **AC Unit** connector.

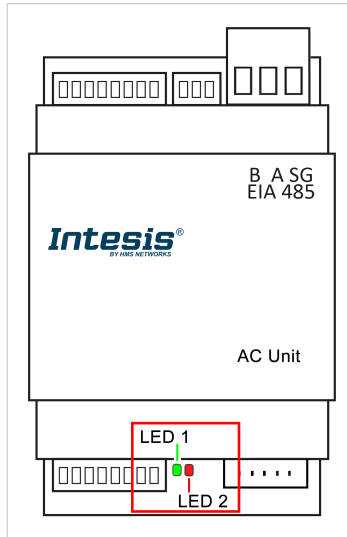

When powering the gateway up, both LEDs blink once and then turn off. After that, LEDs will behave as described in the table below:

LED	Status	Description
When the gateway is set for BACnet MS/TP		
L1 Green	ON	EIA-485 bus link performed
	Flickering	Activity on the EIA-485 bus
	OFF	EIA-485 bus link not performed
L2 Red	ON	Ecodan-gateway communication error
	Blinking	Ecodan unit error
	Flashing	Ecodan-gateway communication OK
When the gateway is set for Modbus RTU		
L1 Green	Blinking	Communication error Ecodan unit error
	Flashing	Normal operation
L1 Green + L2 Red	Pulse	Gateway startup
LED PATTERNS:		
Flickering: 90 % on / 10 % off		
Blinking: 50 % on / 50 % off		
Flashing: 10 % on / 90 % off		
Pulse: 5 sec on / then off		

5.5. Technical Specifications

Housing	Plastic, type PC (UL 94 V-0) Net dimensions (HxWxD): 93 x 53 x 58 mm / 3.7 x 2.1 x 2.3" Color: Light grey. RAL 7035
Net weight	85 g (3 oz)
Terminal wiring	Wire cross-section/gauge per terminal: One core: 0.2 .. 2.5 mm ² (24 .. 11 AWG) Two cores: 0.2 .. 1.5mm ² (24 .. 15 AWG) Three cores: Not permitted Use solid or stranded wires (twisted or with ferrule).
Mounting	DIN rail or wall
EIA-485 port BACnet MS/TP - Modbus RTU	1 x pluggable terminal block (3 poles: B, A, and SG)
AC unit port	1 x Specific socket
LED indicators	2 x Communication status
DIP switches	SW1: Gateway and baudrate configuration SW2: BACnet/Modbus address and temperature unit SW3: Bus polarization and termination
Operational temperature	0 to +70°C / 32 to 158°F
Storage temperature	-20 to 85°C / -4 to 185°F
Operational and storage humidity	5% to 95% RH non-condensing
Isolation between comm. ports	1000 VDC

5.6. Dimensions

Net dimensions (HxWxD):
Millimeters: 93 x 53 x 58 mm
Inches: 3.66 x 2.08 x 2.28"

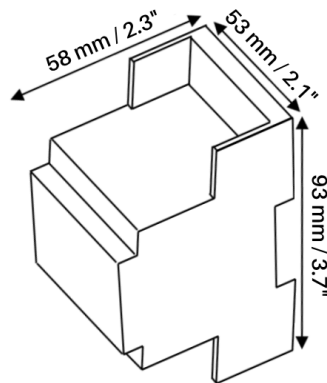

IMPORTANT

Leave enough clear space to wire the gateway easily and for the subsequent manipulation of elements such as connectors, DIP switches, etc.

6. Restore the Factory Settings

To restore the gateway to its factory settings, proceed as follows:

1. Set all switches from DIP switches SW1 and SW2 to **ON**.
2. Reboot the gateway:
 - a. Power it OFF.
 - b. Power it ON.



NOTE

To power the gateway OFF, disconnect it from the AC unit and from the power supply, if there is one. To power the gateway ON, reestablish those connections.

3. After the reboot, LEDs will blink with the SOS Morse sequence:
 - a. Three short blinks
 - b. Three longer blinks
 - c. Three short blinks
4. Set all switches from DIP switches SW1 and SW2 to **OFF** within 30 seconds.



IMPORTANT

If you take longer than 30 seconds, all LEDs will turn off, meaning that the procedure has failed. To retry it, go to step 1 and begin the procedure again.

After this procedure, the LED will flash red, meaning that the gateway has been restored to the factory settings.

7. BACnet Specifications

The following sections provide the gateway's specifications when it is set for BACnet MS/TP.

7.1. Supported Object Types

Object type	ID
Analog-Input	0
Analog-Output	1
Analog-Value	2
Binary-Input	3
Binary-Output	4
Binary-Value	5
Device	8
Multistate-Input	13
Multistate-Output	14
Multistate-Value	19

7.2. Gateway Objects

Name	Possible values	Type	Instance
IN485MIT001A000 ¹	-	8-Device	246000
<p>¹ This object identifies the gateway in the BACnet system, either automatically or manually:</p> <ul style="list-style-type: none"> • Automatic addressing (default): This mode uses a base address of 246000 + the MAC address number selected in the DIP switch SW2. • Manual addressing: The gateway switches to this mode when the Object_Identifier property of this object is overwritten from the BACnet side. If so, the DIP switch SW2 configuration will not be considered for the Device instance calculation until the gateway is reset to the factory settings. See Restore the Factory Settings (page 14). <p>The Object_Name and Description properties of this object can be written. By default, their values are:</p> <ul style="list-style-type: none"> • Object_Name: IN485MIT001A000 • Description: Mitsubishi A2W to BACnet MSTP interface 			
SerialNumber	0 .. 9999999	0-Analog Input	0
DIP_SW_1_status ²	0 .. 255	0-Analog Input	86
<p>² It indicates the status of the DIP switch block SW1 in decimal value. To get the status of each individual switch (position) of SW1, just convert it to binary. The gateway reads this value only when booting up.</p>			
DIP_SW_2_status ³	0 .. 255	0-Analog Input	87
<p>³ It indicates the status of the DIP switch block SW2 in decimal value. To get the status of each individual switch (position) of SW2, just convert it to binary. The gateway reads this value only when booting up.</p>			

7.3. General Objects

Name	Possible values	Type	Instance
IndoorUnitAddress_status ¹	0 .. 255	0-Analog Input	1
IndoorUnitAddress_command ¹	0 .. 255	1-Analog Output	0
¹ Address of the indoor unit where the gateway is connected.			
ErrorFlag_status	0: No Error 1: Error	3-Binary Input	1
ErrorCode_status ²	0: No error Any other value: Error code	0-Analog Input	2
² Error code as shown in a Mitsubishi Electric centralized controllers. For example, when there's an anomaly in the TH1 thermistor, this object will show the hexadecimal value 5101, which is the value displayed in the centralized controller, if present. If the BACnet BMS is set to show values in decimal format, the object will report 20737 instead.			
ErrorSubCode_status ³	0: No error Any other value: Error code	0-Analog Input	3
³ Error code as shown in the Ecodan unit. For example, when there's an anomaly in the TH1 thermistor, this object will show the hexadecimal value 0601, which corresponds to the P1 code reported by the Ecodan unit's screen or wired remote control after applying the conversion used by the Mitsubishi system. If the BACnet BMS is set to show values in decimal format, the register will report 1537 instead. The conversion method used by the Mitsubishi system and a complete list of error codes can be found in Error Codes (page 40) .			
RefrigerantLeakDetectorSignalFlag_status	0: No Error 1: Error	3-Binary Input	3
OperatingTimeCountHour_status ⁴	0 .. 720896 (h)	0-Analog Input	8
⁴ It reports the accumulated operating time of the heat pump in hours. When reaching the maximum value (720896), this register is reset to 0.			
RemoteControlLock_status	0: Unlocked 1: Locked	3-Binary Input	4
RemoteControlLock_command ⁵	0: Unlocked 1: Locked	4-Binary Output	3
⁵ It enables/disables the control of the Ecodan unit through its remote control. If a value of 1 is written in this object, the Ecodan unit can only be controlled through the BMS, and any command sent through any remote control will have no effect.			
OnOff_status	0: Off 1: On	3-Binary Input	5
OnOff_command ⁶	0: Off 1: On	4-Binary Output	4
⁶ This object turns the Ecodan system on and off.			

Name	Possible values	Type	Instance
Operation_status ⁷	0: Not Operating 1: Operating	3-Binary Input	6
⁷ This object reports whether there is a demand for climate and/or DHW, and thus whether the system is operating.			

7.4. Zones Objects

Name	Possible values	Type	Instance
ZonesOnOff_status	0: Off 1: On	3-Binary Input	7
ZonesOperation_status ¹	0: Not Operating 1: Operating	3-Binary Input	8
¹ This register reports whether there is a demand for climate in any zone, and thus whether the climate system is operating.			
ZonesMode_status	1: Heat 2: Cool	13-Multistate Input	0
ZonesMode_command ²	1: Heat 2: Cool	14-Multistate Output	0
² Use this object to set the mode for the climate. Both Zone 1 and Zone 2 will be set in the same mode.			

7.5. Zone 1 Objects

Name	Possible values	Type	Instance
Zone1OnOff_status	0: Off 1: On	3-Binary Input	10
Zone1Operation_status ¹	0: Not Operating 1: Operating	3-Binary Input	11
¹ This object reports whether there is a demand for climate in Zone 1, and thus whether the Zone 1 climate system is operating.			
Zone1ControlType_status	1: Outlet Water Temperature 2: Room Thermostat Ambient Temperature 3: Weather Compensation Curve	13-Multistate Input	2

Name	Possible values	Type	Instance
Zone1ControlType_command ²	1: Outlet Water Temperature 2: Room Thermostat Ambient Temperature 3: Weather Compensation Curve	14-Multistate Output	1
<p>² Set the control type used for Zone 1:</p> <ul style="list-style-type: none"> • 0: Flow temperature control • 1: Room temperature control (Auto adaptation) • 2: Weather compensation curve control <div style="background-color: #f0f0f0; padding: 10px; border: 1px solid #ccc;"> <p> IMPORTANT</p> <ul style="list-style-type: none"> • When the climate mode is set to cooling (ZonesMode_command = 2: Cool), the only control type allowed is 0: Flow temperature control. • For Ecodan systems with two climate zones, only one zone can be set to 1: Room temperature control. </div>			
Zone1TempSetpoint_status	Value in °C or °F	0-Analog Input	9
Zone1TempSetpoint_command ³	Value in °C or °F	1-Analog Output	3
<p>³ This object is used to request a setpoint temperature from the BACnet BMS for Zone 1.</p>			
Zone1TempSetpointLowCustomerLimitHeat_status	Value in °C or °F	0-Analog Input	10
Zone1TempSetpointLowCustomerLimitHeat_command ⁴	Value in °C or °F	1-Analog Output	4
Zone1TempSetpointUpCustomerLimitHeat_status	Value in °C or °F	0-Analog Input	11
Zone1TempSetpointUpCustomerLimitHeat_command ⁴	Value in °C or °F	1-Analog Output	5
Zone1TempSetpointLowCustomerLimitCool_status	Value in °C or °F	0-Analog Input	12
Zone1TempSetpointLowCustomerLimitCool_command ⁴	Value in °C or °F	1-Analog Output	6
Zone1TempSetpointUpCustomerLimitCool_status	Value in °C or °F	0-Analog Input	13
Zone1TempSetpointUpCustomerLimitCool_command ⁴	Value in °C or °F	1-Analog Output	7
<p>⁴ With these objects, you can customize limits to establish a range of temperatures for both heat and cool modes.</p> <p>These limits cannot surpass the limits supported by the Ecodan unit. See the following four objects.</p>			

Name	Possible values	Type	Instance
Zone1TempSetpointUnitLowLimitHeat_status ⁵	Value in °C or °F	0-Analog Input	14
Zone1TempSetpointUnitUpLimitHeat_status ⁵	Value in °C or °F	0-Analog Input	15
Zone1TempSetpointUnitLowLimitCool_status ⁵	Value in °C or °F	0-Analog Input	16
Zone1TempSetpointUnitUpLimitCool_status ⁵	Value in °C or °F	0-Analog Input	17
<p>⁵ These objects report the maximum and minimum temperatures supported by the Ecodan unit for both heat and cool modes.</p> <p>These are absolute limits that cannot be surpassed by means of any other object.</p>			
Zone1TempSetpointAppliedLowLimitHeat_status ⁶	Value in °C or °F	0-Analog Input	18
Zone1TempSetpointAppliedUpLimitHeat_status ⁶	Value in °C or °F	0-Analog Input	19
Zone1TempSetpointAppliedLowLimitCool_status ⁶	Value in °C or °F	0-Analog Input	20
Zone1TempSetpointAppliedUpLimitCool_status ⁶	Value in °C or °F	0-Analog Input	21
<p>⁶ These objects report the limits currently applied for both heat and cool modes.</p>			
Zone1TempRef_status ⁷	Value in °C or °F	0-Analog Input	22
<p>⁷ It reports the current reference temperature for Zone 1.</p>			
Zone1TempBACnetRoomThermAmbientRef_command ⁸	Value in °C or °F	1-Analog Output	8
<p>⁸ Use this object to write the ambient temperature provided by a thermistor installed in the BACnet system. Once a valid value is written in this object, the virtual temperature function is activated. See Virtual Temperature (page 37).</p>			
Zone1TempOutletWaterRef_status ⁸	Value in °C or °F	0-Analog Input	24
<p>⁸ It reports the temperature provided by the Zone 1 flow water thermistor.</p>			
Zone1TempInletWaterRef_status ⁹	Value in °C or °F	0-Analog Input	25
<p>⁹ It reports the temperature provided by the Zone 1 return water thermistor.</p>			

7.6. Zone 2 Objects

Name	Possible values	Type	Instance
Zone2OnOff_status	0: Off 1: On	3-Binary Input	17
Zone2Operation_status ¹	0: Not Operating 1: Operating	3-Binary Input	18
<p>¹ This register reports whether there is a demand for climate in Zone 2, and thus whether the Zone 2 climate system is operating.</p>			

Name	Possible values	Type	Instance
Zone2ControlType_status	1: Outlet Water Temperature 2: Room Thermostat Ambient Temperature 3: Weather Compensation Curve	13-Multistate Input	5
Zone2ControlType_command ²	1: Outlet Water Temperature 2: Room Thermostat Ambient Temperature 3: Weather Compensation Curve	14-Multistate Output	3
<p>² Set the control type used for Zone 2:</p> <ul style="list-style-type: none"> • 0: Flow temperature control • 1: Room temperature control (Auto adaptation) • 2: Weather compensation curve control <div style="background-color: #f0f0f0; padding: 10px; border: 1px solid #ccc;"> <p> IMPORTANT</p> <ul style="list-style-type: none"> • When the climate mode is set to cooling (ZonesMode_command = 2: Cool), the only control type allowed is 0: Flow temperature control. • For Ecodan systems with two climate zones, only one zone can be set to 1: Room temperature control. </div>			
Zone2TempSetpoint_status	Value in °C or °F	0-Analog Input	43
Zone2TempSetpoint_command ³	Value in °C or °F	1-Analog Output	17
<p>³ This object is used to request a setpoint temperature from the BACnet BMS for Zone 2.</p>			
Zone2TempSetpointLowCustomerLimitHeat_status	Value in °C or °F	0-Analog Input	44
Zone2TempSetpointLowCustomerLimitHeat_command ⁴	Value in °C or °F	1-Analog Output	18
Zone2TempSetpointUpCustomerLimitHeat_status	Value in °C or °F	0-Analog Input	45
Zone2TempSetpointUpCustomerLimitHeat_command ⁴	Value in °C or °F	1-Analog Output	19
Zone2TempSetpointLowCustomerLimitCool_status	Value in °C or °F	0-Analog Input	46

Name	Possible values	Type	Instance
Zone2TempSetpointLowCustomerLimitCool_command ⁴	Value in °C or °F	1-Analog Output	20
Zone2TempSetpointUpCustomerLimitCool_status	Value in °C or °F	0-Analog Input	47
Zone2TempSetpointUpCustomerLimitCool_command ⁴	Value in °C or °F	1-Analog Output	21
<p>⁴ With these objects, you can customize limits to establish a range of temperatures for both heat and cool modes.</p> <p>These limits cannot surpass the limits supported by the Ecodan unit. See the following four objects.</p>			
Zone2TempSetpointUnitLowLimitHeat_status ⁵	Value in °C or °F	0-Analog Input	48
Zone2TempSetpointUnitUpLimitHeat_status ⁵	Value in °C or °F	0-Analog Input	49
Zone2TempSetpointUnitLowLimitCool_status ⁵	Value in °C or °F	0-Analog Input	50
Zone2TempSetpointUnitUpLimitCool_status ⁵	Value in °C or °F	0-Analog Input	51
<p>⁵ These objects report the maximum and minimum temperatures supported by the Ecodan unit for both heat and cool modes.</p> <p>These are absolute limits that cannot be surpassed by means of any other object.</p>			
Zone2TempSetpointAppliedLowLimitHeat_status ⁶	Value in °C or °F	0-Analog Input	52
Zone2TempSetpointAppliedUpLimitHeat_status ⁶	Value in °C or °F	0-Analog Input	53
Zone2TempSetpointAppliedLowLimitCool_status ⁶	Value in °C or °F	0-Analog Input	54
Zone2TempSetpointAppliedUpLimitCool_status ⁶	Value in °C or °F	0-Analog Input	55
<p>⁶ These objects report the limits currently applied for both heat and cool modes.</p>			
Zone2TempRef_status ⁷	Value in °C or °F	0-Analog Input	56
<p>⁷ It reports the current reference temperature for Zone 2.</p>			
Zone2TempBACnetRoomThermAmbientRef_command ⁸	Value in °C or °F	1-Analog Output	22
<p>⁸ Use this object to write the ambient temperature provided by a thermistor installed in the BACnet system. Once a valid value is written in this object, the virtual temperature function is activated. See Virtual Temperature (page 37).</p>			
Zone2TempOutletWaterRef_status ⁸	Value in °C or °F	0-Analog Input	58
<p>⁸ It reports the temperature provided by the Zone 2 flow water thermistor.</p>			
Zone2TempInletWaterRef_status ⁹	Value in °C or °F	0-Analog Input	59
<p>⁹ It reports the temperature provided by the Zone 2 return water thermistor.</p>			

7.7. Domestic Hot Water Objects

Name	Possible values	Type	Instance
DHWOnOff_status	0: Off 1: On	3-Binary Input	22
DHWOnOff_command	0: Off 1: On	4-Binary Output	15
DHWOperation_status ¹	0: Not Operating 1: Operating	3-Binary Input	23
¹ This object reports whether there is a demand for DHW, and thus whether the DHW system is operating.			
DHWTempSetpoint_status	Value in °C or °F	0-Analog Input	61
DHWTempSetpoint_command ²	Value in °C or °F	1-Analog Output	24
² This object is used to request a setpoint temperature for the DHW from the BACnet BMS.			
DHWTempSetpointCustomLowLimit_status	Value in °C or °F	0-Analog Input	62
DHWTempSetpointCustomLowLimit_command ³	Value in °C or °F	1-Analog Output	25
DHWTempSetpointCustomUpLimit_status	Value in °C or °F	0-Analog Input	63
DHWTempSetpointCustomUpLimit_command ³	Value in °C or °F	1-Analog Output	26
³ With these objects, you can customize limits to establish a range of temperatures for the DHW. These limits cannot surpass the limits supported by the water tank. See the following two objects.			
DHWTempSetpointTankLowLimit_status ⁴	Value in °C or °F	0-Analog Input	64
DHWTempSetpointTankUpLimit_status ⁴	Value in °C or °F	0-Analog Input	65
⁴ These objects report the maximum and minimum temperatures supported by the water tank. These are absolute limits that cannot be surpassed by means of any other object.			
DHWTempSetpointAppliedLowLimit_status ⁵	Value in °C or °F	0-Analog Input	66
DHWTempSetpointAppliedUpLimit_status ⁵	Value in °C or °F	0-Analog Input	67
⁵ These objects report the temperature limits currently applied for the DHW.			
DHWTempTankRef_status ⁶	Value in °C or °F	0-Analog Input	68
⁶ It reports the reference temperature for the DHW. This temperature is provided by the water tank thermistor(s).			
DHWEcoMode_status	0: Off 1: On	3-Binary Input	26
DHWEcoMode_command ⁷	0: Off 1: On	4-Binary Output	18
⁷ It sets the domestic hot water ECO mode on/off.			
DHWPowerfulOperation_status	0: Off 1: On	3-Binary Input	29
DHWPowerfulOperation_command ⁸	0: Off 1: On	4-Binary Output	21
⁸ It sets the DHW tank's built-in electric resistor on/off.			
DHWDisinfectionMode_status ⁹	0: Off 1: On	3-Binary Input	30

Name	Possible values	Type	Instance
⁹ It reports the Antilegionella cycle status (on/off).			

7.8. Outdoor Unit Temperature Objects

Name	Possible values	Type	Instance
TempA2WUnitOutdoorAmbientRef_status ¹	Value in °C or °F	0-Analog Input	72
¹ It reports the ambient temperature provided by the outdoor unit.			
TempRefrigerantRef_status ²	Value in °C or °F	0-Analog Input	73
² It reports the refrigerant temperature in the outdoor unit.			
TempOutletWaterRef_status ³	Value in °C or °F	0-Analog Input	74
³ It reports the flow water temperature from the outdoor unit.			
TempInletWaterRef_status ⁴	Value in °C or °F	0-Analog Input	76
⁴ It reports the return water temperature from the outdoor unit.			

7.9. Extra Signals for the BACnet Configuration

Name	Possible values	Type	Instance
HolidayMode_status	0: Off 1: On	3-Binary Input	31
HolidayMode_command ¹	0: Off 1: On	4-Binary Output	23
¹ It turns the Holiday mode on/off.			
EmergencyOperation_status ²	0: Off 1: On	3-Binary Input	33
² It reports the Emergency Operation status (on/off).			
DefrostStartUp_status ³	0: Defrost/Start Up 1: Hot Start	3-Binary Input	34
³ It reports the operation status.			
ThreeWayValveOperation_status ⁴	0: Climatize 1: DHW	3-Binary Input	36
⁴ It reports the 3-way valve status (climate/DHW).			
BackUpHeaterOperationLevel1_status ⁵	0: Off 1: On	3-Binary Input	37
⁵ It reports the Ecodan unit resistor 1 status (on/off).			
BackUpHeaterOperationLevel2_status ⁶	0: Off 1: On	3-Binary Input	38
⁶ It reports the Ecodan unit resistor 2 status (on/off).			
CompressorOperation_status ⁷	0: Off 1: On	3-Binary Input	40
⁷ It reports the compressor status (on/off).			

Name	Possible values	Type	Instance
CompressorOperatingTime_status ⁸	0 .. 720896 (h)	0-Analog Input	77
CompressorOperatingTime_command ⁸	0 .. 720896 (h)	1-Analog Output	30
<p>⁸ This object reports the accumulated operating time of the compressor in hours. Write a value of 0 in the _command object to manually reset the counter. When reaching the maximum value (720896 h), this object is reset to 0.</p>			
CirculationPumpOperation_status ⁹	0: Off 1: On	3-Binary Input	41
<p>⁹ It reports the circulation pump status (on/off).</p>			
CirculationPumpOperatingTime_status ¹⁰	0 .. 720896 (h)	0-Analog Input	78
CirculationPumpOperatingTime_command ¹⁰	0 .. 720896 (h)	1-Analog Output	31
<p>¹⁰ This object reports the accumulated operating time of the circulation pump in hours. Write a value of 0 in the _command object to manually reset the counter. When reaching the maximum value (720896 h), this object is reset to 0.</p>			
WaterFlowRate_status ¹¹	0 .. 720896 (l/h)	0-Analog Input	79
<p>¹¹It reports the water flow rate provided by the flow sensor. When reaching the maximum value (720896 l/h), this register is reset to 0.</p>			
EnergyConsumptionTotal_status ¹²	0 .. 2147483647 (kWh)	0-Analog Input	81
<p>¹² It reports the total accumulated energy consumption for the climate and DHW systems in kilowatt-hours. When reaching the maximum value (2147483647 kWh), this object resets to 0. This data is also reset:</p> <ul style="list-style-type: none"> • The value of all EnergyConsumption objects. • The internal dates of these objects. 			
EnergyConsumptionZonesHeat_status ¹³	0 .. 2147483647 (kWh)	0-Analog Input	82
EnergyConsumptionZonesCool_status ¹³	0 .. 2147483647 (kWh)	0-Analog Input	83
EnergyConsumptionDHW_status ¹³	0 .. 2147483647 (kWh)	0-Analog Input	84
<p>¹³ These objects report the accumulated energy consumption for heating mode, cooling mode, and the DHW, respectively, in kilowatt-hours. When reaching the maximum value (2147483647 kWh), these objects and their dates are reset to 0.</p>			
ZonesHeatModeSupport_status ¹⁴	0: No 1: Yes	3-Binary Input	45
<p>¹⁴ It reports if the Ecodan system supports heating.</p>			
ZonesCoolModeSupport_status ¹⁵	0: No; 1: Yes	3-Binary Input	46
<p>¹⁵ It reports if the Ecodan system supports cooling.</p>			
DHWSupport_status ¹⁶	0: No 1: Yes	3-Binary Input	47

Name	Possible values	Type	Instance
¹⁶ It reports if the Ecodan system supports domestic hot water.			

8. Modbus Specifications

The following sections provide the gateway's specifications when it is set for Modbus RTU.

8.1. Implemented Modbus Functions

The IN485MIT001A000 gateway implements the following standard Modbus functions:

- 03: Read Holding Registers
- 04: Read Input Registers
- 06: Write Single Register
- 16: Write Multiple Registers



IMPORTANT

Even though function 16 is available, the gateway does not allow writing operations on more than one register with the same request, so the length field when using this function should always be one.

8.1.1. Modbus Physical Layer

The IN485MIT001A000 gateway implements a Modbus RTU (server) interface to be connected to an EIA-485 bus. It features an 8-N-2 communication (eight data bits, no parity, and two stop bits) with several available baud rates: **2400 -default-**, 4800, 9600, 19200, 38400, 57600, 76800, and 115200 bps. It also supports 8-N-1 communication (eight data bits, no parity, and one stop bit).



NOTE

AUTO-DETECT FUNCTION. The gateway will automatically detect the communication type (8-N-1 or 8-N-2) and set itself accordingly. No user action or manual settings are required.

8.2. Modbus Registers



IMPORTANT

The IN485MIT001A000 gateway has a polling limit of 50 registers. Therefore, it is not possible to poll more than 50 registers simultaneously, for example, if the same Tx frame asks for the status of more than 50 registers.



NOTICE

The initialization value for all registers is 0x8000 (-32768).



NOTICE

When receiving an invalid value, registers behave differently depending on their function:

- Temperature related registers are reset to the initialization value.
- The other registers retain their previous value.

8.2.1. Gateway Registers

Register name	Possible values	Modbus address (base 0)	PLC address (base 1)	R/W
Device Identifier	0x3100 (12544)	460	461	R
FW Version MSB ¹	Value in hexadecimal format	461	462	R
¹ It reports the first two numbers of the firmware version. Example: Version 1.2.3.4 will show C, which is the hexadecimal format corresponding to 12.				
FW Version LSB ²	Value in hexadecimal format	462	463	R
² It reports the last two numbers of the firmware version. Example: Version 1.2.3.4 will show 22, which is the hexadecimal format corresponding to 34.				
Device Reset ³	1	463	464	R/W
³ Write a 1 in this register to reset the gateway.				
Baudrate	1: 2400 bps 2: 4800 bps 3: 9600 bps 4: 19200 bps 5: 38500 bps 6: 57600 bps 7: 76800 bps 8: 115200 bps	464	465	R
Modbus Server Address	1 .. 63	465	466	R
Dip-Switches Value ⁴	Current DIP switches value	466	467	R
⁴ It reports a decimal value that, converted to binary, shows each switch OFF (0) or ON (1) position for both SW1 and SW2.				

8.2.2. General Registers

Register name	Possible values	Modbus address (base 0)	PLC address (base 1)	R/W
Indoor Unit Address	0 .. 65535	101	102	R
Error: Flag	0: No error present 1: Error present	107	108	R
Error: Code ¹	0: No error Any other value: Error code	108	109	R
¹ Error code as shown in Mitsubishi Electric centralized controllers. For example, when there's an anomaly in the TH1 thermistor, this register will show the hexadecimal value 5101, which is the value displayed in the centralized controller, if present. If the Modbus BMS is set to show values in decimal format, the register will report 20737 instead.				

Register name	Possible values	Modbus address (base 0)	PLC address (base 1)	R/W
Error: Sub Code ²	0: No error Any other value: Error code	109	110	R
<p>² Error code as shown in the Ecodan unit. For example, when there's an anomaly in the TH1 thermistor, this register will show the hexadecimal value 0601, which corresponds to the P1 code reported by the Ecodan unit's screen or wired remote control after applying the conversion used by the Mitsubishi system. If the Modbus BMS is set to show values in decimal format, the register will report 1537 instead.</p> <p>The conversion method used by the Mitsubishi system and a complete list of error codes can be found in Error Codes (page 40).</p>				
Refrigerant Error: Flag	0: No error present 1: Error present	114	115	R
Operating Time Counter (h) ³	0 .. 65535 (h)	116	117	R
<p>³ It reports the accumulated operating time of the heat pump in hours.</p> <p>When reaching the maximum value (65535 h), this register is reset to 0.</p>				
Remote Control Lock ⁴	0: Unlocked (default value) 1: Locked	118	119	R/W
<p>⁴ It enables/disables the control of the Ecodan unit through its remote control.</p> <p>If a value of 1 is written in this register, the Ecodan unit can only be controlled through the BMS, and any command sent through any remote control will have no effect.</p>				
Modbus Control Lock ⁵	0: Unlocked (default value) 1: Locked	119	120	R/W
<p>⁵ It enables/disables the control of the Ecodan unit through the BMS.</p> <p>If a value of 1 is written in this register, the Ecodan unit can only be controlled through its remote control, and any command sent from the BMS will have no effect.</p>				
<div style="display: flex; align-items: center;">  <div> <p>TROUBLESHOOTING</p> <p>If for an unknown reason the gateway does not work, ensure this register is set to 0.</p> </div> </div>				
On/Off ⁶	0: Off 1: On	130	131	R/W
<p>⁶ This register turns the Ecodan system on and off.</p>				
Operation ⁷	0: No operating 1: Operating	131	132	R
<p>⁷ This register reports whether there is a demand for climate and/or DHW, and thus whether the system is operating.</p>				

8.2.3. Zones Registers

Register name	Possible values	Modbus address (base 0)	PLC address (base 1)	R/W
Zones: On/Off	0: Off 1: On	140	141	R
Zones: Operation ¹	0: Not operating 1: Operating	141	142	R
¹ This register reports whether there is a demand for climate in any zone, and thus whether the climate system is operating.				
Zones: Mode ²	1: Heat 2: Cool	142	143	R/W
² Use this register to set the mode for the climate. Both Zone 1 and Zone 2 will be set in the same mode.				

8.2.4. Zone 1 Registers

Register name	Possible values	Modbus address (base 0)	PLC address (base 1)	R/W
Zone 1: On/Off	0: Off 1: On	146	147	R
Zone 1: Operation ¹	0: Not operating 1: Operating	147	148	R
¹ This register reports whether there is a demand for climate in Zone 1, and thus whether the Zone 1 climate system is operating.				
Zone 1: Control Type ²	0: Outlet Water Temperature 1: Room Thermostat Ambient Temperature 2: Weather Compensation Curve	149	150	R/W
² Set the control type used for Zone 1:				
<ul style="list-style-type: none"> • 0: Flow temperature control • 1: Room temperature control (Auto adaptation) • 2: Weather compensation curve control 				
<div style="background-color: #f0f0f0; padding: 10px;"> <p> IMPORTANT</p> <ul style="list-style-type: none"> • When the climate mode is set to cooling (Zones: Mode = 2: Cool), the only control type allowed is 0: Flow temperature control. • For Ecodan systems with two climate zones, only one zone can be set to 1: Room temperature control. </div>				

Register name	Possible values	Modbus address (base 0)	PLC address (base 1)	R/W
Zone 1: Temperature: Setpoint ³	Value in °C; °F; x1; x10	160	161	R/W
³ This register is used to request a setpoint temperature from the Modbus BMS for Zone 1.				
Zone 1: Temperature: Setpoint: Custom Lower Limit: Heat ⁴	Value in °C; °F; x1; x10	161	162	R/W
Zone 1: Temperature: Setpoint: Custom Upper Limit: Heat ⁴	Value in °C; °F; x1; x10	162	163	R/W
Zone 1: Temperature: Setpoint: Custom Lower Limit: Cool ⁴	Value in °C; °F; x1; x10	163	164	R/W
Zone 1: Temperature: Setpoint: Custom Upper Limit: Cool ⁴	Value in °C; °F; x1; x10	164	165	R/W
⁴ With these registers, you can customize limits to establish a range of temperatures for both heat and cool modes. These limits cannot surpass the limits supported by the Ecodan unit. See the following four registers.				
Zone 1: Temperature: Setpoint: Unit Lower Limit: Heat ⁵	Value in °C; °F; x1; x10	165	166	R
Zone 1: Temperature: Setpoint: Unit Upper Limit: Heat ⁵	Value in °C; °F; x1; x10	166	167	R
Zone 1: Temperature: Setpoint: Unit Lower Limit: Cool ⁵	Value in °C; °F; x1; x10	167	168	R
Zone 1: Temperature: Setpoint: Unit Upper Limit: Cool ⁵	Value in °C; °F; x1; x10	168	169	R
⁵ These registers report the maximum and minimum temperatures supported by the Ecodan unit for both heat and cool modes. These are absolute limits that cannot be surpassed by means of any other register.				
Zone 1: Temperature: Setpoint: Applied Lower Limit: Heat ⁶	Value in °C; °F; x1; x10	169	170	R
Zone 1: Temperature: Setpoint: Applied Upper Limit: Heat ⁶	Value in °C; °F; x1; x10	170	171	R
Zone 1: Temperature: Setpoint: Applied Lower Limit: Cool ⁶	Value in °C; °F; x1; x10	171	172	R
Zone 1: Temperature: Setpoint: Applied Upper Limit: Cool ⁶	Value in °C; °F; x1; x10	172	173	R
⁶ These registers report the limits currently applied for both heat and cool modes.				

Register name	Possible values	Modbus address (base 0)	PLC address (base 1)	R/W
Zone 1: Temperature: Reference ⁷	Value in °C; °F; x1; x10	180	181	R
⁷ It reports the current reference temperature for Zone 1.				
Zone 1: Temperature: Modbus Room Thermostat Ambient Reference ⁸	Value in °C; °F; x1; x10	181	182	W
⁸ Use this register to write the ambient temperature provided by a thermistor installed in the Modbus system. Once a valid value is written in this register, the virtual temperature function is activated. See Virtual Temperature (page 37) .				
Zone 1: Temperature: Outlet Water Reference ⁸	Value in °C; °F; x1; x10	184	185	R
⁸ It reports the temperature provided by the Zone 1 flow water thermistor.				
Zone 1: Temperature: Inlet Water Reference ⁹	Value in °C; °F; x1; x10	185	186	R
⁹ It reports the temperature provided by the Zone 1 return water thermistor.				

8.2.5. Zone 2 Registers

Register name	Possible values	Modbus address (base 0)	PLC address (base 1)	R/W
Zone 2: On/Off	0: Off 1: On	230	231	R
Zone 2: Operation ¹	0: Not operating 1: Operating	231	232	R
¹ This register reports whether there is a demand for climate in Zone 2, and thus whether the Zone 2 climate system is operating.				
Zone 2: Control Type ²	0: Outlet Water Temperature 1: Room Thermostat Ambient Temperature 2: Weather Compensation Curve	235	236	R/W

Register name	Possible values	Modbus address (base 0)	PLC address (base 1)	R/W
² Set the control type used for Zone 2: <ul style="list-style-type: none"> • 0: Flow temperature control • 1: Room temperature control (Auto adaptation) • 2: Weather compensation curve control 				
<div style="background-color: #e0e0e0; padding: 10px;">  IMPORTANT <ul style="list-style-type: none"> • When the climate mode is set to cooling (Zones: Mode = 2: Cool), the only control type allowed is 0: Flow temperature control. • For Ecodan systems with two climate zones, only one zone can be set to 1: Room temperature control. </div>				
Zone 2: Temperature: Setpoint ³	Value in °C; °F; x1; x10	240	241	R/W
³ This register is used to request a setpoint temperature from the Modbus BMS for Zone 2.				
Zone 2: Temperature: Setpoint: Custom Lower Limit: Heat ⁴	Value in °C; °F; x1; x10	241	242	R/W
Zone 2: Temperature: Setpoint: Custom Upper Limit: Heat ⁴	Value in °C; °F; x1; x10	242	243	R/W
Zone 2: Temperature: Setpoint: Custom Lower Limit: Cool ⁴	Value in °C; °F; x1; x10	243	244	R/W
Zone 2: Temperature: Setpoint: Custom Upper Limit: Cool ⁴	Value in °C; °F; x1; x10	244	245	R/W
⁴ With these registers, you can customize limits to establish a range of temperatures for both heat and cool modes. These limits cannot surpass the limits supported by the Ecodan unit. See the following four registers.				
Zone 2: Temperature: Setpoint: Unit Lower Limit: Heat ⁵	Value in °C; °F; x1; x10	245	246	R
Zone 2: Temperature: Setpoint: Unit Upper Limit: Heat ⁵	Value in °C; °F; x1; x10	246	247	R
Zone 2: Temperature: Setpoint: Unit Lower Limit: Cool ⁵	Value in °C; °F; x1; x10	247	248	R
Zone 2: Temperature: Setpoint: Unit Upper Limit: Cool ⁵	Value in °C; °F; x1; x10	248	249	R
⁵ These registers report the maximum and minimum temperatures supported by the Ecodan unit for both heat and cool modes. These are absolute limits that cannot be surpassed by means of any other register.				

Register name	Possible values	Modbus address (base 0)	PLC address (base 1)	R/W
Zone 2: Temperature: Setpoint: Applied Lower Limit: Heat ⁶	Value in °C; °F; x1; x10	249	250	R
Zone 2: Temperature: Setpoint: Applied Upper Limit: Heat ⁶	Value in °C; °F; x1; x10	250	251	R
Zone 2: Temperature: Setpoint: Applied Lower Limit: Cool ⁶	Value in °C; °F; x1; x10	251	252	R
Zone 2: Temperature: Setpoint: Applied Upper Limit: Cool ⁶	Value in °C; °F; x1; x10	252	253	R
⁶ These registers report the limits currently applied for both heat and cool modes.				
Zone 2: Temperature: Reference ⁷	Value in °C; °F; x1; x10	254	255	R
⁷ It reports the current reference temperature for Zone 2.				
Zone 2: Temperature: Modbus Room Thermostat Ambient Reference ⁸	Value in °C; °F; x1; x10	256	257	W
⁸ Use this register to write the ambient temperature provided by a thermistor installed in the Modbus system. Once a valid value is written in this register, the virtual temperature function is activated. See Virtual Temperature (page 37) .				
Zone 2: Temperature: Outlet Water Reference ⁸	Value in °C; °F; x1; x10	258	259	R
⁸ It reports the temperature provided by the Zone 2 flow water thermistor.				
Zone 2: Temperature: Inlet Water Reference ⁹	Value in °C; °F; x1; x10	259	260	R
⁹ It reports the temperature provided by the Zone 2 return water thermistor.				

8.2.6. Domestic Hot Water Registers

Register name	Possible values	Modbus address (base 0)	PLC address (base 1)	R/W
DHW: On/Off	0: Off 1: On	270	271	R
DHW: Operation ¹	0: Not operating 1: Operating	271	272	R
¹ This register reports whether there is a demand for DHW, and thus whether the DHW system is operating.				
DHW: Temperature: Setpoint ²	Value in °C; °F; x1; x10	276	277	R/W
² This register is used to request a setpoint temperature for the DHW from the Modbus BMS.				
DHW: Temperature: Setpoint: Custom Lower Limit ³	Value in °C; °F; x1; x10	277	278	R/W

Register name	Possible values	Modbus address (base 0)	PLC address (base 1)	R/W
DHW: Temperature: Setpoint: Custom Upper Limit ³	Value in °C; °F; x1; x10	278	279	R/W
³ With these registers, you can customize limits to establish a range of temperatures for the DHW. These limits cannot surpass the limits supported by the water tank. See the following two registers.				
DHW: Temperature: Setpoint: Tank Lower Limit ⁴	Value in °C; °F; x1; x10	279	280	R
DHW: Temperature: Setpoint: Tank Upper Limit ⁴	Value in °C; °F; x1; x10	280	281	R
⁴ These registers report the maximum and minimum temperatures supported by the water tank. These are absolute limits that cannot be surpassed by means of any other register.				
DHW: Temperature: Setpoint: Applied Lower Limit ⁵	Value in °C; °F; x1; x10	281	282	R
DHW: Temperature: Setpoint: Applied Upper Limit ⁵	Value in °C; °F; x1; x10	282	283	R
⁵ These registers report the temperature limits currently applied for the DHW.				
DHW: Temperature: Tank Reference ⁶	Value in °C; °F; x1; x10	285	286	R
⁶ It reports the reference temperature for the DHW. This temperature is provided by the water tank thermistor(s).				
DHW: Eco Mode ⁷	0: Off 1: On	290	291	R/W
⁷ It sets the domestic hot water ECO mode on/off.				
DHW: Boost ⁸	0: Off 1: On	298	299	R/W
⁸ It sets the DHW tank's built-in electric resistor on/off.				
DHW: Legionella ⁹	0: Off 1: On	300	301	R
⁹ It reports the Antilegionella cycle status (on/off).				

8.2.7. Outdoor Unit Temperature Registers

Register name	Possible values	Modbus address (base 0)	PLC address (base 1)	R/W
Temperature: A2W Unit Outdoor Ambient Reference ¹	Value in °C; °F; x1; x10	304	305	R
¹ It reports the ambient temperature provided by the outdoor unit.				
Temperature: Refrigerant Reference ²	Value in °C; °F; x1; x10	305	306	R
² It reports the refrigerant temperature in the outdoor unit.				
Temperature: Outlet Water Reference ³	Value in °C; °F; x1; x10	306	307	R
³ It reports the flow water temperature from the outdoor unit.				
Temperature: Inlet Water Reference ⁴	Value in °C; °F; x1; x10	308	309	R

Register name	Possible values	Modbus address (base 0)	PLC address (base 1)	R/W
⁴ It reports the return water temperature from the outdoor unit.				

8.2.8. Extra Signals for the Modbus Configuration

Register name	Possible values	Modbus address (base 0)	PLC address (base 1)	R/W
Holiday Mode ¹	0: Off 1: On	360	361	R/W
¹ It turns the Holiday mode on/off.				
Emergency Operation ²	0: Off 1: On	362	363	R
² It reports the Emergency Operation status (on/off).				
Defrost/Normal Operation ³	0: Defrost 1: Normal Operation	363	364	R
³ It reports the operation status (defrost/normal).				
3-Way Valve Operation ⁴	0: Climatize 1: DHW	365	366	R
⁴ It reports the 3-way valve status (climate/DHW).				
Back Up Heater Operation: Level 1 ⁵	0: Off 1: On	366	367	R
⁵ It reports the Ecodan unit resistor 1 status (on/off).				
Back Up Heater Operation: Level 2 ⁶	0: Off 1: On	367	368	R
⁶ It reports the Ecodan unit resistor 2 status (on/off).				
Compressor Operation ⁷	0: Off 1: On	369	370	R
⁷ It reports the compressor status (on/off).				
Compressor Operating Time ⁸	0 .. 65535 (h)	370	371	R/W
⁸ It reports the accumulated operating time of the compressor in hours. Write a value of 0 to manually reset the counter. When reaching the maximum value (65535 h), this register is reset to 0.				
Pump Operation ⁹	0: Off 1: On	371	372	R
⁹ It reports the circulation pump status (on/off).				
Pump Operating Time ¹⁰	0 .. 65535 (h)	372	373	R/W
¹⁰ It reports the accumulated operating time of the circulation pump in hours. Write a value of 0 to manually reset the counter. When reaching the maximum value (65535 h), this register is reset to 0.				

Register name	Possible values	Modbus address (base 0)	PLC address (base 1)	R/W
Water Flow Rate ¹¹	0 .. 65535 (l/h)	373	374	R
¹¹ It reports the water flow rate provided by the flow sensor. When reaching the maximum value (65535 l/h), this register is reset to 0.				
Energy Consumption: Total ¹²	0 .. 65535 (kWh)	378	379	R/W
¹² It reports the total accumulated energy consumption for the climate and DHW systems in kilowatt-hours. When manually writing a value of 0 in this register, this data is reset: <ul style="list-style-type: none"> • The value of all Energy Consumption registers. • The internal date of these registers. When reaching the maximum value (65535 kWh), this register is reset to 0.				
Energy Consumption: Zones: Heat ¹³	0 .. 65535 (kWh)	379	380	R
Energy Consumption: Zones: Cool ¹³	0 .. 65535 (kWh)	380	381	R
Energy Consumption: DHW ¹³	0 .. 65535 (kWh)	381	382	R
¹³ These registers report the accumulated energy consumption for heating mode, cooling mode, and the DHW, respectively, in kilowatt-hours. When reaching the maximum value (65535 kWh), these registers and their dates are reset to 0.				
Zones: Heat Mode Support ¹⁴	0: No 1: Yes	383	384	R
¹⁴ It reports if the Ecodan system supports heating.				
Zones: Cool Mode Support ¹⁵	0: No 1: Yes	384	385	R
¹⁵ It reports if the Ecodan system supports cooling.				
DHW Support ¹⁶	0: No 1: Yes	385	386	R
¹⁶ It reports if the Ecodan system supports domestic hot water.				

9. Virtual Temperature

The Virtual Temperature function is a mechanism designed to offset the difference between the current setpoint temperature used by the Ecodan unit and the actual room temperature in the living area.

To compensate for that difference, the IN485MIT001A000 gateway allows you to use the temperature obtained through third-party thermistors connected to the BACnet/Modbus BMS to establish the reference temperature for the Ecodan climate system.

REQUISITES TO USE THE VIRTUAL TEMPERATURE FUNCTION

- The Ecodan system includes at least one climate zone (heating/cooling).
- The living area where you intend to apply this function has a third-party thermistor connected to the Modbus/BACnet BMS.

WHEN TO USE THE VIRTUAL TEMPERATURE FUNCTION

Use this function when there is a mismatch between the ambient temperature of the living area and the temperature delivered by the system.



IMPORTANT

Before using the Virtual Temperature function, you should check if the reason behind the mismatch is related to a system misconfiguration, such as an error in assigning remote controllers to the system's zones, and correct it.

The Virtual Temperature function is not a substitute for a properly configured Ecodan system.

The Ecodan system itself incorporates highly advanced technology that offers multiple options to adjust the system in the most efficient manner while keeping the comfort in the living areas.

USAGE EXAMPLE

In the following image, the target temperature requested by the user is 23°C. However, the remote controller is placed at some distance from the heat emitter, and its thermistor is perceiving a temperature of 22°C. Additionally, the living area is even further away, and the actual temperature there is 20°C.

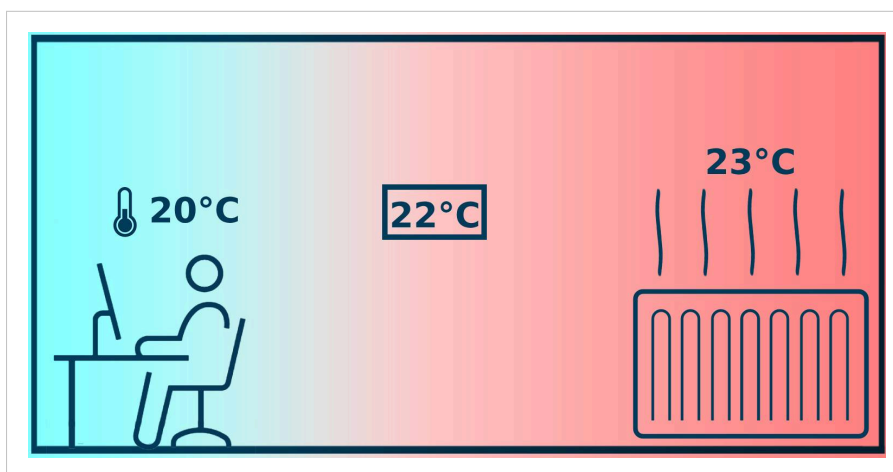

Given this case, you can place a third-party thermistor in the living area, connect it to the BACnet/Modbus BMS, and use the gateway's Virtual Temperature function to offset the difference between the temperature delivered by the system and the temperature perceived in the living area.

HOW THE VIRTUAL TEMPERATURE FUNCTION WORKS

When the Virtual Temperature function is active, the gateway is constantly applying the following formula:

$$S_{AC} = T_{AC} - (T_{BMS} - S_{BMS})$$

Where:

- S_{AC} : Recalculated temperature setpoint sent to the Ecodan system after the gateway applies the formula.
- T_{AC} : Ecodan system's reference temperature. This is the temperature perceived by the thermistor in the remote controller, which is used to report the room temperature.
- T_{BMS} : Ambient temperature reported by the thermistor placed in the living area and connected to the BMS side.
- S_{BMS} : Temperature setpoint requested from the BMS side for that zone. This is the target temperature that the user wants in the living area.

Given the case of the image, the values used by the Virtual Temperature function are as follows:

$$S_{AC} = 22 - (20 - 23)$$

When resolving the equation, we get the following result:

$$S_{AC} = 22 - (-3)$$

$$S_{AC} = 22 + 3$$

$$S_{AC} = 25$$

This means that the gateway is sending a setpoint temperature of 25°C, thereby achieving the desired temperature of 23°C that the user specified.



IMPORTANT

When the Virtual Temperature is active, the setpoint temperature reported by the Ecodan remote controller will differ from the actual temperature delivered by the system.

Once activated, the Virtual Temperature function recalculates the setpoint whenever any of these values change, either from the Ecodan system itself (through its remote control, for example) or from the BMS.

HOW TO ACTIVATE THE VIRTUAL TEMPERATURE FUNCTION

Follow this procedure:

1. From the BMS control interface, write the desired setpoint temperature using the dedicated signal. There is a specific signal for each zone:

BACnet	Modbus
Zone1TempSetpoint_command	Zone 1: Temperature: Setpoint (protocol address: 160; PLC address: 161)
Zone2TempSetpoint_command	Zone 2: Temperature: Setpoint (protocol address: 240; PLC address: 241)

2. Write the temperature value reported by the thermistor connected to the BMS using the dedicated signal. There is a specific signal for each zone:

BACnet	Modbus
Zone1TempBACnetRoomThermAmbientRef_command ¹	Zone 1: Temperature: Modbus Room Thermostat Ambient Reference (protocol address: 181; PLC address: 182) ¹
Zone2TempBACnetRoomThermAmbientRef_command ¹	Zone 2: Temperature: Modbus Room Thermostat Ambient Reference (protocol address: 256; PLC address: 257) ¹
¹ When starting up the gateway, these signals will report a value of 0x8000 (-32768), meaning that the function is not activated.	



FOR BACNET

When starting up the gateway, the **Present_Value** property for the **Zone1TempBACnetRoomThermAmbientRef_command** and **Zone2TempBACnetRoomThermAmbientRef_command** objects is 0, and the **Reliability** property displays **UNRELIABLE_OTHER (7)**. This is the expected behavior, since no external temperature reference has been provided to the object yet. However, after receiving a valid value, the **Reliability** property changes to **NO_FAULT_DETECTED (0)**. After that, any value can be used in the temperature range, including 0.



IMPORTANT

Once these signals receive valid values, the Virtual Temperature function will activate

HOW TO DEACTIVATE THE VIRTUAL TEMPERATURE FUNCTION

Write a value of 0x8000 (-32768) in the dedicated signal (see ¹ above).

10. Error Codes

10.1. Gateway Error Codes



NOTE

These error codes are related to the gateway and will not appear in the Ecodan unit's screen or in its wired remote control.

Error Code in Modbus/BACnet	Error Description
0	No active error
-1	Communication error between the Ecodan unit and the gateway

10.2. Mitsubishi Electric Ecodan Error Codes

Error codes are reported by the Ecodan unit's screen or wired remote control using a two-digit alphanumeric code. This code is converted to a four-digit hexadecimal value using the following equivalences when reported through the BMS:

Ecodan 1st digit	BMS	Ecodan 2nd digit	BMS
A	00	1 .. 9	01 .. 09
b	01	A .. F	10 .. 15
E	02	O	16
F	03	H	17
J	04	J	18
L	05	L	19
P	06	P	20
U	07	U	21



NOTICE

For example, if the Ecodan unit reports the error code P1, the BMS will report it as 0601.

If the BMS is set to report values in decimal format instead, just convert that value: 0x0601 = 1537.

The BMS reports these errors through the object **ErrorSubCode_status** for BACnet and the register **Error: Sub Code** for Modbus.

Error code in the Ecodan system	Error Subcode in BACnet/Modbus (in 0x)	Description
L3	0503	Circulation water temperature overheat protection
L4	0504	Tank water temperature overheat protection
L5	0505	Indoor unit thermistor failure (THW1, THW2, THW5, THW5A, THW5B, THW6, THW7, THW8, THW9)

Error code in the Ecodan system	Error Subcode in BACnet/Modbus (in 0x)	Description
L6	0506	Circulation water freeze protection
L8	0508	Heating operation error
L9	0509	Low flow rate detected by the flow sensor in the primary circuit (heat source side) Low flow rate detected by the flow switch in the primary circuit (Zone 1 side) Low flow rate detected by the flow switch in the primary circuit (Zone 2 side)
LA	0510	Pressure sensor failure
Lb	0511	High pressure protection
LC	0512	Boiler circulation water temperature overheat protection
LD	0513	Boiler flow water thermistor failure (THWB1, THWB2)
LE	0514	Boiler operation error
LF	0515	Flow sensor failure
LH	0517	Boiler circulation water freeze protection
LJ	0518	DHW operation error
LL	0519	Setting errors of DIP switches on the FTC control board
P1	0601	Room temperature thermistor failure (TH1A, TH1B)
P2	0602	Liquid temperature thermistor failure (TH2)
P6	0606	Anti-freeze protection of plate heat exchanger
PE	0614	Inlet water temperature abnormality
E1/E2	0201/0202	Main remote controller control board failure
E3/E5	0203/0205	Main remote controller communication failure (Transmission error)
E4	0204	Main remote controller communication failure (Reception error)
E6	0206	Indoor/outdoor communication failure (Signal receiving error)
E7	0207	Indoor/outdoor communication failure (Transmission error)
E8	0208	Interface unit/Flow temp. controller-outdoor unit communication error (Signal receiving error) (Outdoor unit)
E9	0209	Interface unit/Flow temp. controller-outdoor unit communication error (Transmitting error) (Outdoor unit)
EA	0210	Miswiring of the interface unit/Flow temp. controller-outdoor unit connecting wire
Eb	0211	Miswiring of the interface unit/Flow temp. controller-outdoor unit connecting wire (reverse wiring or disconnection)
EC	0212	Startup time over
Ed	0213	Serial communication error
EE	0214	Combination error between FTC and outdoor unit
EF	0215	Non-defined check code
J1 .. J8	0401 .. 0408	Wireless remote controller/wireless receiver communication error
F3	0303	63L connector open
F5	0305	63H connector open

Error code in the Ecodan system	Error Subcode in BACnet/Modbus (in 0x)	Description
F9	0309	63L and 63H connector open
U1	0701	High pressure (High pressure switch 63H operated)
U2	0702	High discharge temperature High compressor surface temperature
U3	0703	Open/short circuit of discharge thermistor (TH4)
U4	0704	Open/short circuit of outdoor unit thermistors (TH3, TH6, TH7, TH8)
U5	0705	Abnormal temperature of heat sink (TH8)
U6	0706	Power module failure
U7	0707	Too low superheat due to low discharge temperature
U8	0708	Outdoor fan motor failure
U9	0709	Overtoltage error Undervoltage error Input current sensor error/L1-phase open error Abnormal power synchronous signal PFC error (Overtoltage/Undervoltage/Overcurrent) PFC/IGBT error (Undervoltage)
Ud	0713	Overheat protection
UE	0714	Abnormal pressure detected by the pressure sensor (63HS)
UF	0715	Compressor overcurrent interruption (When compressor locked)
UH	0717	Current sensor error or input current error
UL	0719	Low pressure (63L operated)
UP	0720	Compressor overcurrent interruption

**NOTICE**

These error codes may differ depending on the specific Ecodan unit model.

Consult the Ecodan system's original documentation to get a complete list of the error codes.

If you detect an unknown error code, please contact the Mitsubishi Electric support department.

**IMPORTANT**

If the Ecodan unit is connected to a Mitsubishi Electric centralized control, the centralized control will report errors using a different system of codes, which we are not listing here. In this case, the BMS reports those errors through the register **Error: Code** for Modbus and the object **ErrorCode_status** for BACnet.