

User Manual

Revision 1.000
English

Modbus Master / MQTT Broker - Converter

(Order Code: HD67C04-2-B2, HD67C04-2-G43-B2, HD67C04-2-G43-E-B2, HD67C04-2-G43-VPN-B2, HD67C04-2-G43-E-VPN-B2, HD67C04-5-B2, HD67C04-5-G43-B2, HD67C04-5-G43-E-B2, HD67C04-5-G43-VPN-B2, HD67C04-5-G43-E-VPN-B2)

For Website information:

- www.adfweb.com?Product=HD67C04-2-B2
- www.adfweb.com?Product=HD67C04-2-G43-B2
- www.adfweb.com?Product=HD67C04-2-G43-E-B2
- www.adfweb.com?Product=HD67C04-2-G43-VPN-B2
- www.adfweb.com?Product=HD67C04-2-G43-E-VPN-B2
- www.adfweb.com?Product=HD67C04-5-B2
- www.adfweb.com?Product=HD67C04-5-G43-B2
- www.adfweb.com?Product=HD67C04-5-G43-E-B2
- www.adfweb.com?Product=HD67C04-5-G43-VPN-B2
- www.adfweb.com?Product=HD67C04-5-G43-E-VPN-B2

For Price information:

- www.adfweb.com?Price=HD67C04-B2

Benefits and Main Features:

- ⊕ Power Supply 18...35V DC and 8...24 V AC
- ⊕ Temperature range: -40°C/+85°C (-40°F/+185°F)



User Manual

For others MQTT Broker products, see also the following links:

Converter MQTT Broker to

- www.adfweb.com?Product=HD67C00 (MQTT Broker)
- www.adfweb.com?Product=HD67C03 (Serial)
- www.adfweb.com?Product=HD67C05 (Modbus Slave)
- www.adfweb.com?Product=HD67C06 (Modbus TCP Master)
- www.adfweb.com?Product=HD67C07 (Modbus TCP Slave)
- www.adfweb.com?Product=HD67C08 (BACnet Master)
- www.adfweb.com?Product=HD67C09 (BACnet Slave)
- www.adfweb.com?Product=HD67C10 (CAN)
- www.adfweb.com?Product=HD67C11 (CANopen)
- www.adfweb.com?Product=HD67C12 (DALI)
- www.adfweb.com?Product=HD67C13 (DeviceNet Master)
- www.adfweb.com?Product=HD67C14 (DeviceNet Slave)
- www.adfweb.com?Product=HD67C15 (DMX)
- www.adfweb.com?Product=HD67C16 (EtherNet/IP Slave)
- www.adfweb.com?Product=HD67C17 (J1939)
- www.adfweb.com?Product=HD67C18 (KNX)
- www.adfweb.com?Product=HD67C19 (NMEA 0183)
- www.adfweb.com?Product=HD67C20 (NMEA 2000)
- www.adfweb.com?Product=HD67C21 (PROFIBUS Master)
- www.adfweb.com?Product=HD67C22 (PROFIBUS Slave)
- www.adfweb.com?Product=HD67C23 (PROFINET Slave)
- www.adfweb.com?Product=HD67C24 (SNMP Manager)
- www.adfweb.com?Product=HD67C25 (SNMP Agent)
- www.adfweb.com?Product=HD67C26 (EtherNet/IP Master)
- www.adfweb.com?Product=HD67C27 (PROFINET Master)
- www.adfweb.com?Product=HD67C28 (OPC UA Client)
- www.adfweb.com?Product=HD67C29 (OPC UA Server)
- www.adfweb.com?Product=HD67C30 (Ethernet)
- www.adfweb.com?Product=HD67C31 (IEC61850 Server)
- www.adfweb.com?Product=HD67C32 (IEC61850 Client)
- www.adfweb.com?Product=HD67G68 (HTTP/REST Client)
- www.adfweb.com?Product=HD67G69 (HTTP/REST Server)

Do you have an your customer protocol?

- www.adfweb.com?Product=HD67003

Do you need to choose a device? do you want help?

- www.adfweb.com?Cmd=helpme

INDEX:

	Page
INDEX	2
UPDATED DOCUMENTATION	2
REVISION LIST	2
WARNING	2
TRADEMARKS	2
SECURITY ALERT	3
EXAMPLE OF CONNECTION	4
CONNECTION SCHEME	5
CHARACTERISTICS	9
CONFIGURATION	9
POWER SUPPLY	10
LEDS	11
ETHERNET	12
RS232	12
RS485	13
MOBILE	13
RECOVERY BUTTON	14
USE OF ADFWEB DISCOVERY TOOL SOFTWARE	15
USE OF COMPOSITOR SW67C04	16
NEW CONFIGURATION / OPEN CONFIGURATION	17
SOFTWARE OPTIONS	19
SET COMMUNICATION	20
SET MQTT BROKER	24
MQTT SET TOPIC	26
MQTT SET BRIDGES	28
MODBUS SET ACCESS	30
UPDATE DEVICE	32
USER/PASSWORD	34
TEMPLATE STRING: DEFINITION OF MQTT PAYLOAD	35
MECHANICAL DIMENSIONS	37
ORDERING INFORMATIONS	41
ACCESSORIES	42
DISCLAIMER	43
OTHER REGULATIONS AND STANDARDS	43
WARRANTIES AND TECHNICAL SUPPORT	44
RETURN POLICY	44

UPDATED DOCUMENTATION:

Dear customer, we thank you for your attention and we remind you that you need to check that the following document is:

- ✚ Updated
- ✚ Related to the product you own

To obtain the most recently updated document, note the “document code” that appears at the top right-hand corner of each page of this document.

With this “Document Code” go to web page www.adfweb.com/download/ and search for the corresponding code on the page. Click on the proper “Document Code” and download the updates.

REVISION LIST:

Revision	Date	Author	Chapter	Description
1.000	20/10/2025	Ln	All	First release version

WARNING:

ADFweb.com reserves the right to change information in this manual about our product without warning.
ADFweb.com is not responsible for any error this manual may contain.

TRADEMARKS:

All trademarks mentioned in this document belong to their respective owners.

SECURITY ALERT:**GENERAL INFORMATION**

To ensure safe operation, the device must be operated according to the instructions in the manual. When using the device, legal and safety regulation are required for each individual application. The same applies also when using accessories.

INTENDED USE

Machines and systems must be designed so the faulty conditions do not lead to a dangerous situation for the operator (i.e. independent limit switches, mechanical interlocks, etc.).

QUALIFIED PERSONNEL

The device can be used only by qualified personnel, strictly in accordance with the specifications. Qualified personnel are persons who are familiar with the installation, assembly, commissioning and operation of this equipment and who have appropriate qualifications for their job.

RESIDUAL RISKS

The device is state-of-the-art and is safe. The instruments can represent a potential hazard if they are inappropriately installed and operated by untrained personnel. These instructions refer to residual risks with the following symbol:



This symbol indicates that non-observance of the safety instructions is a danger for people that could lead to serious injury or death and / or the possibility of damage.

CE CONFORMITY

The declaration is made by our company. You can send an email to support@adfweb.com or give us a call if you need it.

EXAMPLE OF CONNECTION:

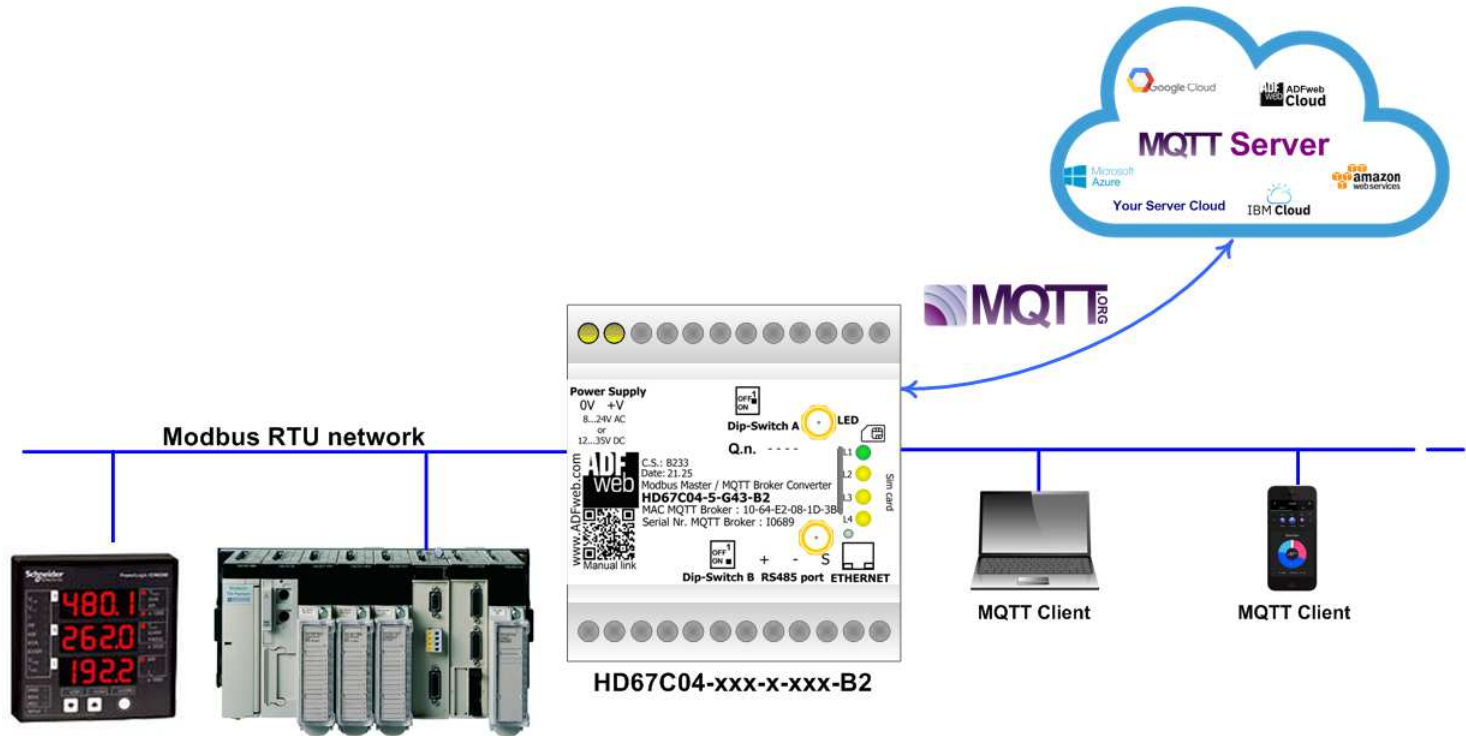

CONNECTION SCHEME:

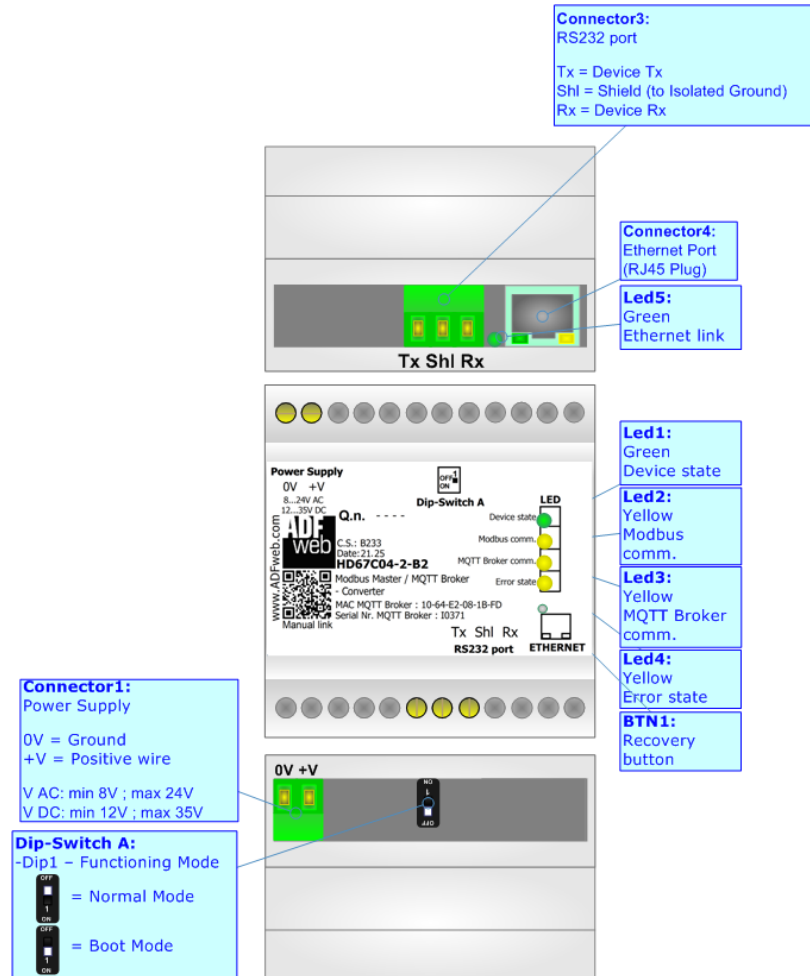

Figure 1a: Connection scheme for HD67C04-2-B2

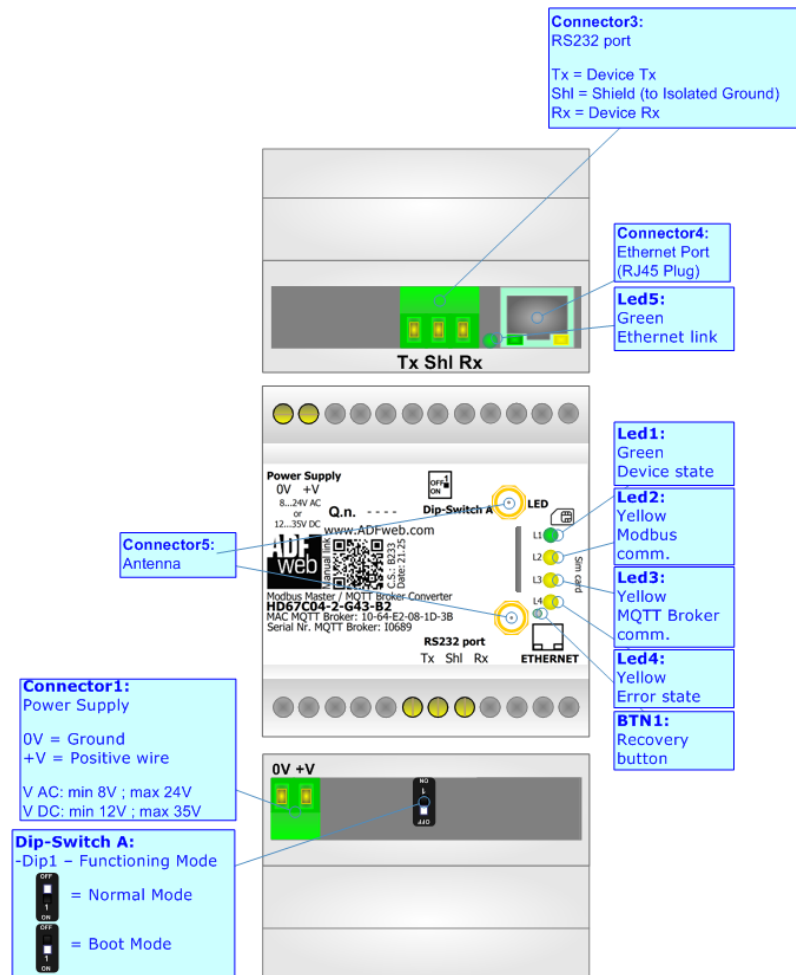

Figure 1b: Connection scheme for HD67C04-2-G43-x-xxx-B2

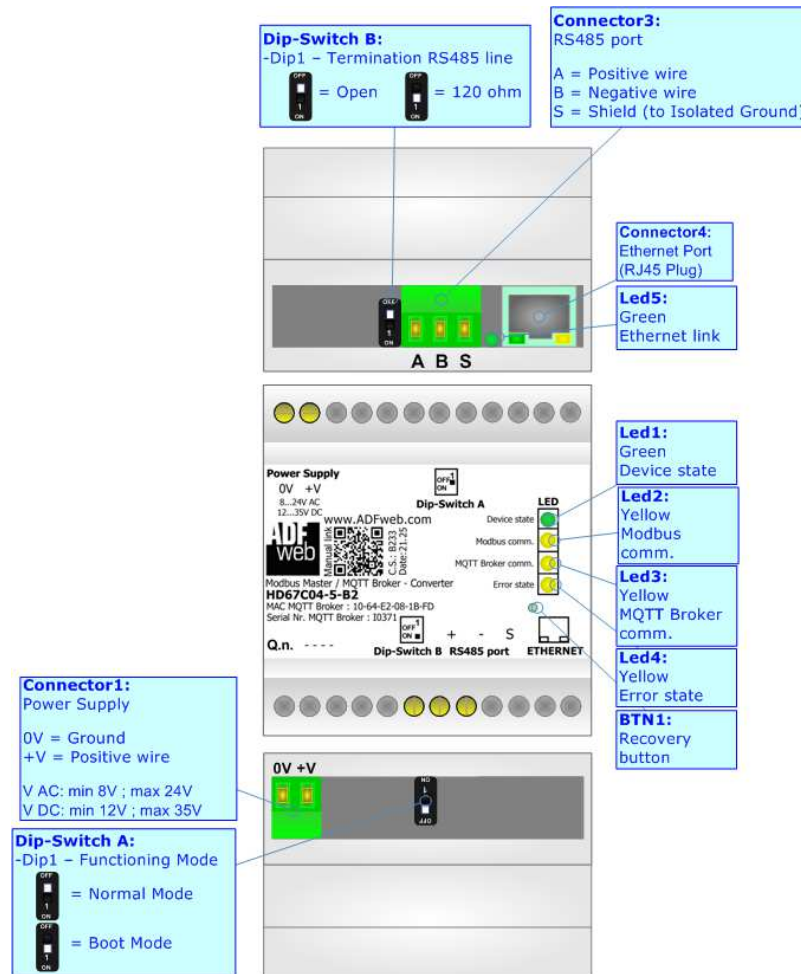

Figure 1c: Connection scheme for HD67C04-5-B2

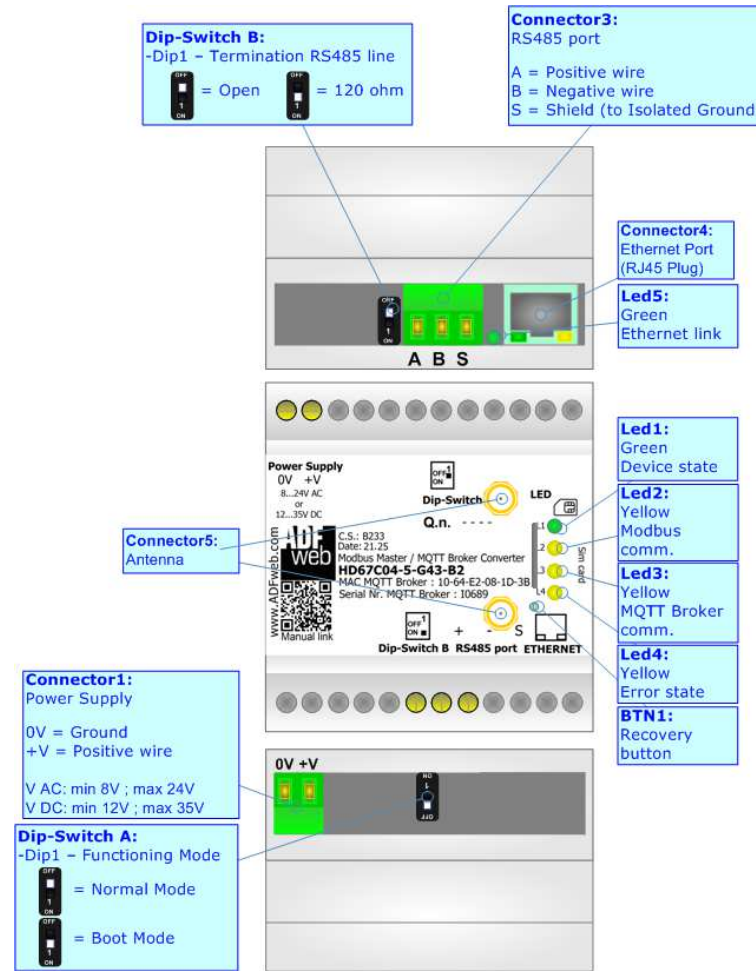

Figure 1d: Connection scheme for HD67C04-5-G43-x-xxx-B2

CHARACTERISTICS:

The HD67C04-xxx-x-xxx-B2 is a Modbus Master / MQTT Broker Converter.

It allows the following characteristics:

- Electrical isolation between Ethernet and Power Supply;
- Mountable on 35mm Rail DIN;
- Wide power supply input range: 12...35V DC and 8...24V AC;
- Wide temperature range: -40°C / +85°C [-40°F / +185°F].

CONFIGURATION:

You need Compositor SW67C04 software on your PC in order to perform the following:

- Define the parameter of MQTT;
- Define the parameter of Modbus line;
- Define the list of allowed MQTT Clients;
- Define the list of MQTT topic published and subscribed from/to Modbus;
- Define the list of topics to be forwarded via the internal bridge;
- Update the device.

POWER SUPPLY:

The devices can be powered at 8...24V AC and 12...35V DC. For more details see the two tables below.

VAC		VDC	
Vmin	Vmax	Vmin	Vmax
8V	24V	12V	35V

Consumption at 24V DC:

Device	Consumption [W/VA]
HD67C04-xxx-x-xxx-B2	5

Connector1:
Power Supply
0V = Ground
+V = Positive wire
V AC: min 8V ; max 24V
V DC: min 12V ; max 35V

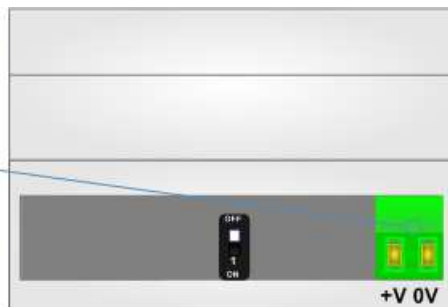

Caution: Not reverse the polarity power

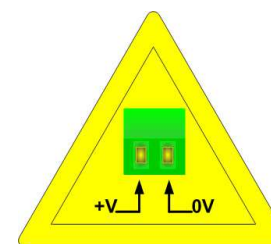

HD67C04-xxx-x-xxx-B2

LEDS:

The device has got four LEDs that are used to give information of the functioning status.
The various meanings of the LEDs are described in the table below.

LED	Normal Mode	Recovery Mode
1: Device State (green)	Blinks slowly (~1Hz)	Blinks quickly
2: Modbus comm. (yellow)	Blinks when Modbus communication is running	Blinks quickly
3: MQTT Broker comm. (yellow)	Blinks when a MQTT topic is received	Blinks quickly
4: Error State (yellow)	ON: an error occurs OFF: no errors	Blinks quickly

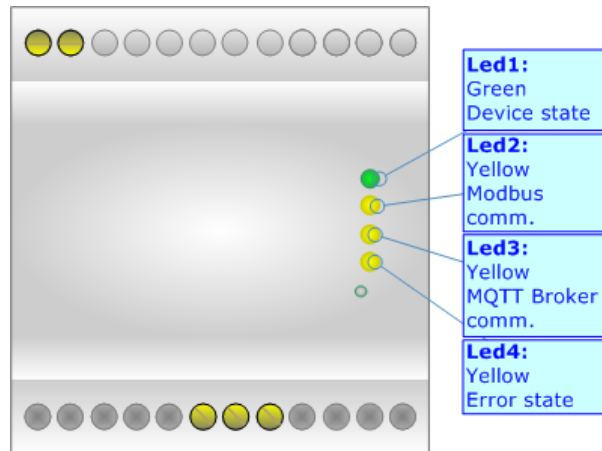

ETHERNET:

The Ethernet port is used for programming the device and for MQTT communication.

The Ethernet connection must be made using Connector4 of HD67C04-xxx-x-xxx-B2 with at least a Category 5E cable. The maximum length of the cable should not exceed 100m. The cable has to conform to the T568 norms relative to connections in cat.5 up to 100 Mbps. To connect the device to an Hub/Switch is recommended the use of a straight cable, to connect the device to a PC is recommended the use of a cross cable.

The interface has one MAC Addresses for MQTT.

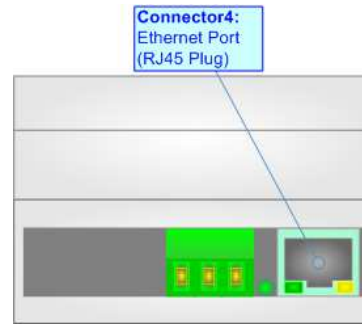

RS232:

The connection from RS232 socket to a serial port (example one from a personal computer) must be made with a Null Modem cable (a serial cable where the pins 2 and 3 are crossed). It is recommended that the RS232 cable not exceed 15 meters.

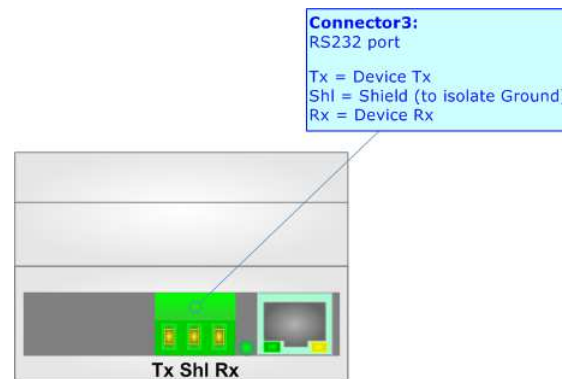

RS485:

For terminate the RS485 line with a 120Ω resistor it is necessary to put ON dip 1, like in figure.

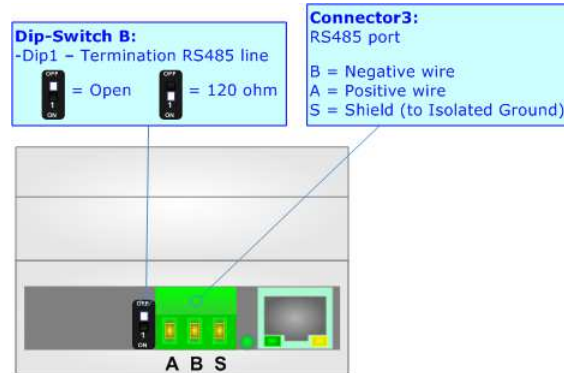

The maximum length of the cable should be 1200m (4000 feet).

Here some codes of cables:

- Belden: p/n 8132 - 2x 28AWG stranded twisted pairs conductor + foil shield + braid shield;
- Belden p/n 82842 - 2x 24AWG stranded twisted pairs conductor + foil shield + braid shield;
- Tasker: p/n C521 - 1x 24AWG twisted pair conductor + foil shield + braid shield;
- Tasker: p/n C522 - 2x 24AWG twisted pairs conductor + foil shield + braid shield.

MOBILE:

The HD67C04-G43-x-xxx-B2 uses LTE module. The Antenna connector is a SMA Female ('Female Outer Shell' and 'Female Receptacle') so the Antenna must have a SMA Male connector. The physical SIM card type is Micro-Sim.

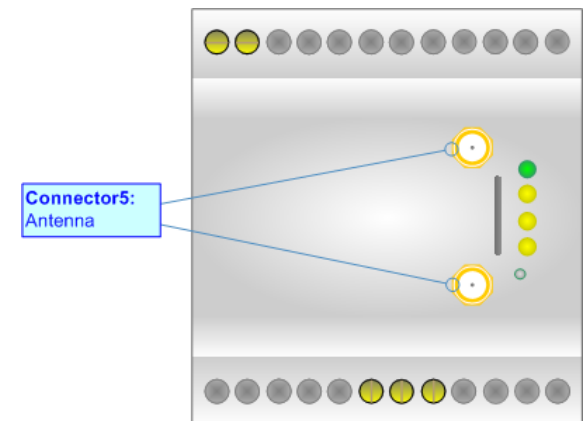

RECOVERY BUTTON:

In order to recover the device in case of wrong firmware updating or any error that compromises correct functioning of the device, it is necessary to press the BTN1. After pressing, the device will be switched in Recovery Mode and it will be possible to update again the firmware or reset the device using the default IP address 192.168.2.206 via webserver.

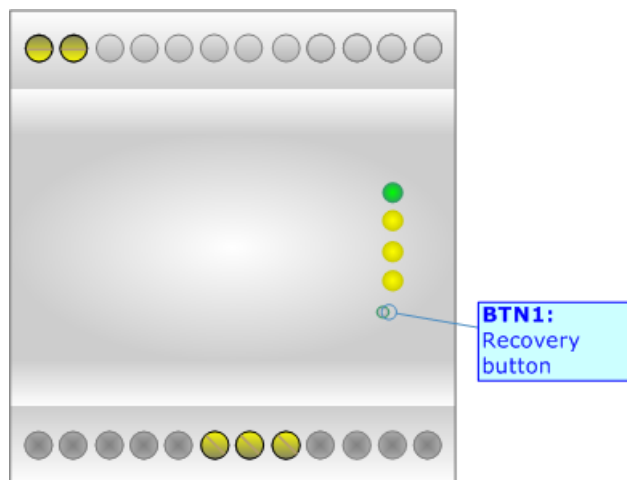



USE OF ADFWEB DISCOVERY TOOL SOFTWARE:

To discover the device into the network and see its IP Address, use the available software that runs with Windows called "ADFweb Discovery Tool". It is downloadable from here: www.adfweb.com/download/filefold/ADFweb_Discovery_Tool.zip.
The software works with MSWindows (XP, Vista, Seven, 8, 10, 11; 32/64bit).

USE OF COMPOSITOR SW67C04:

To configure the Converter, use the available software that runs with Windows called SW67C04. It is downloadable on the site www.adfweb.com and its operation is described in this document. The software works with MS Windows (XP, Vista, Seven, 8, 10, 11; 32/64bit).

When launching the SW67C04, the window below appears (Fig. 2).



Note:

It is necessary to have installed .Net Framework 4.

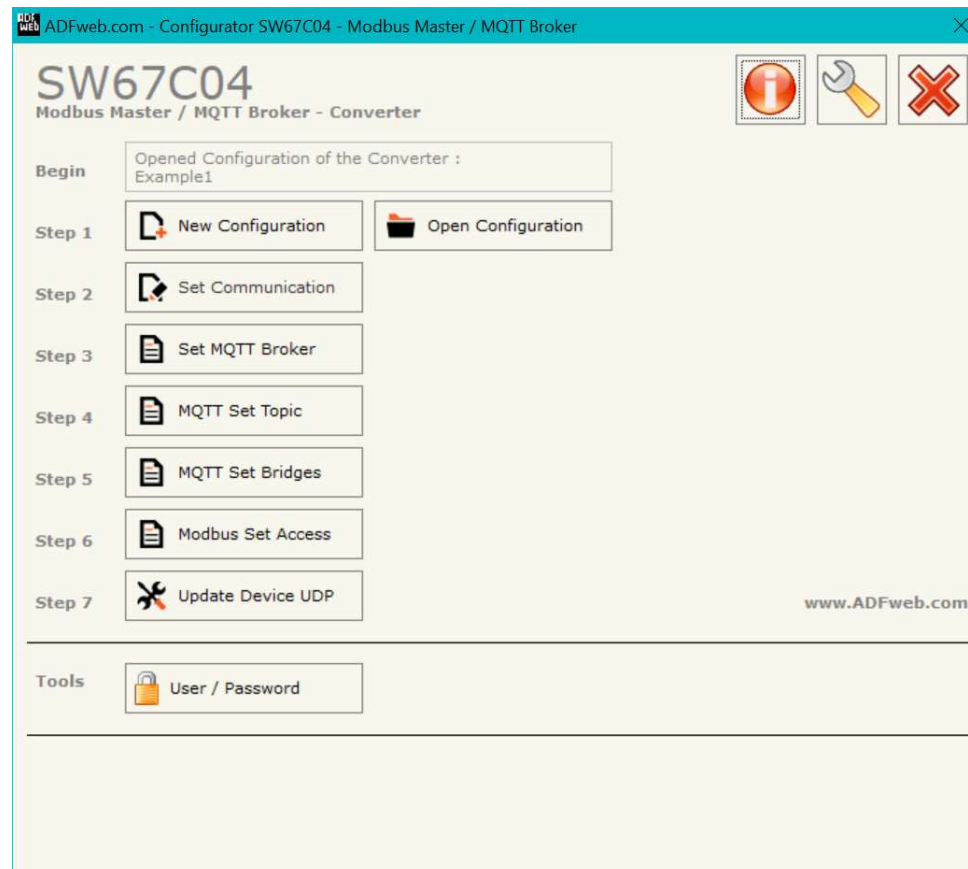
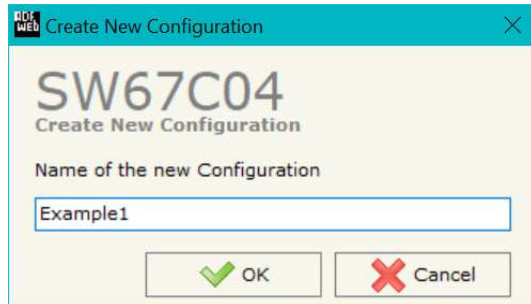

Figure 2: Main window for SW67C04

NEW CONFIGURATION / OPEN CONFIGURATION:

The “**New Configuration**” button creates the folder which contains the entire device’s configuration.



A device’s configuration can also be imported or exported:

- To clone the configurations of a Programmable “Modbus Master / MQTT Broker - Converter” in order to configure another device in the same manner, it is necessary to maintain the folder and all its contents;
- To clone a project in order to obtain a different version of the project, it is sufficient to duplicate the project folder with another name and open the new folder with the button “**Open Configuration**”.

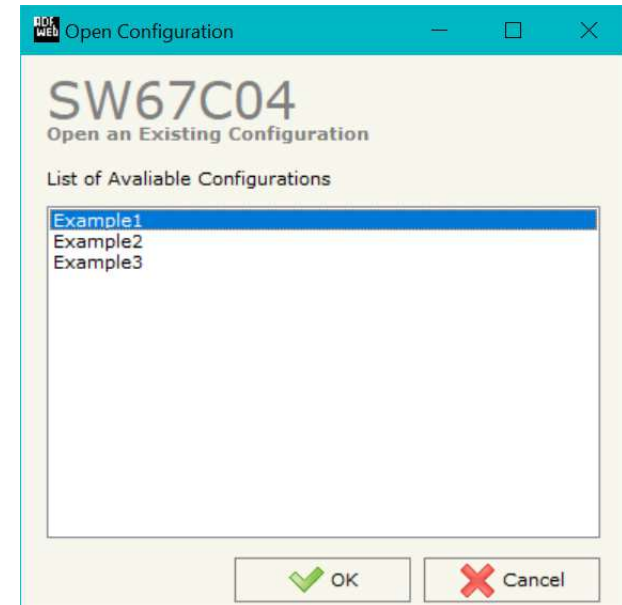

SOFTWARE OPTIONS:

By pressing the “**Settings**” () button there is the possibility to change the language of the software and check the updatings for the compositor.

In the section “Language” it is possible to change the language of the software.

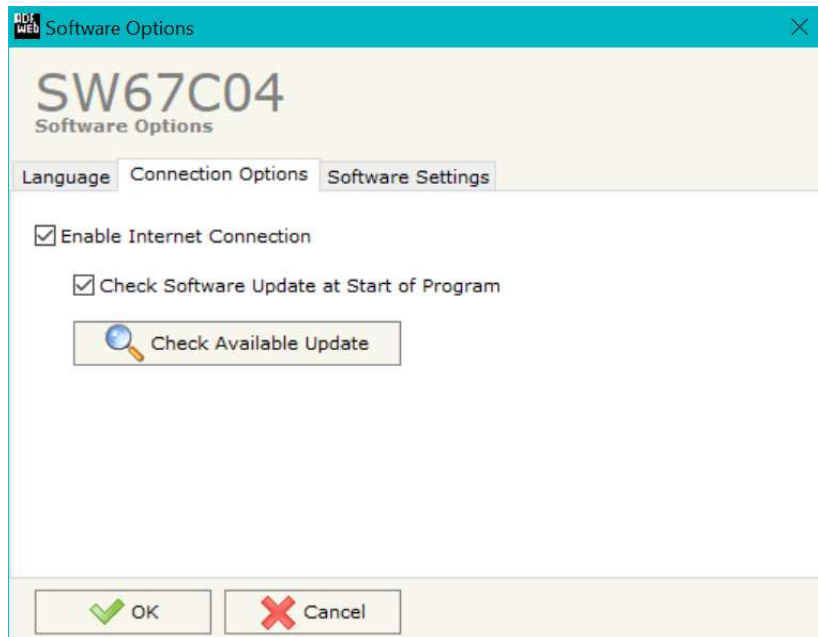

In the section “Connection Options”, it is possible to check if there are some updatings of the software compositor in ADFweb.com website. Checking the option “**Check Software Update at Start of Program**”, the SW67C04 check automatically if there are updatings when it is launched.

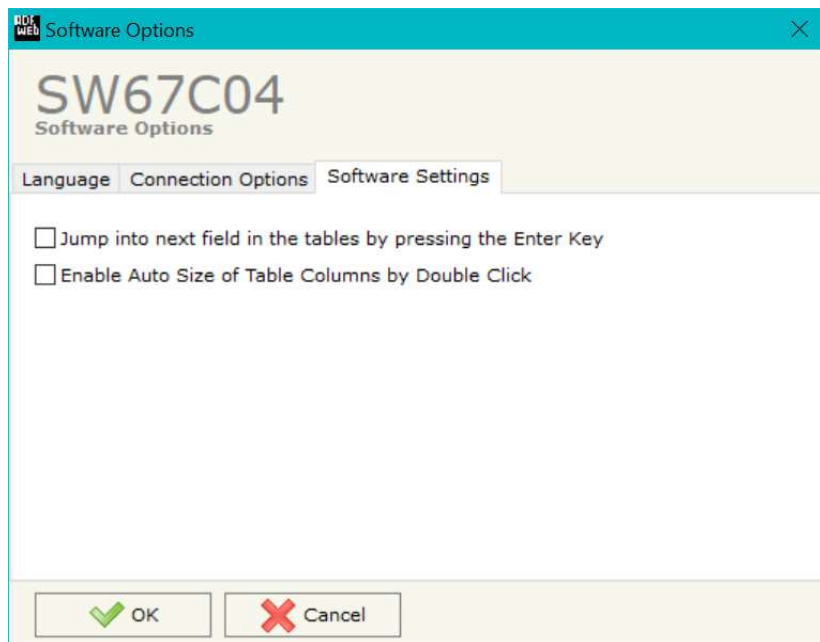

In the section "Software Settings", it is possible to enable/disable some keyboard's commands for an easier navigation inside the tables contained in the different sections of the software.

SET COMMUNICATION:

By Pressing the **"Set Communication"** button from the main window for SW67C04 (Fig. 2) the window "Set Communication" appears (Fig. 3).

This window is divided in two sections, one for configuring the MQTT network and the other for the Modbus network.

MQTT Broker section

MQTT BROKER → SELECT PRODUCT CODE:

This section is used to select the product in use. It is possible to have:

- HD67C04-B2;
- HD67C04-G43-B2;
- HD67C04-G43-E-B2;
- HD67C04-G43-VPN-B2;
- HD67C04-G43-E-VPN-B2.

MQTT BROKER → ETHERNET INTERFACES:

This section is used to define the general parameters of Ethernet. The means of the fields are:

- In the field **"Interfaces Configuration"**, it is possible to define the hardware settings of the Ethernet interfaces. For the hardware version with a single Ethernet port, it is mandatory to set "Single Ethernet Interface";
- In the field **"Enable DHCP"**, it is possible to enable the DHCP Client to obtain automatically the IP Address from a DHCP Server in the network;
 - If "Enable DHCP" option is active, it is possible to configure the **"Default IP Address"** and **"Default SubNet Mask"** to set a static IP Address if a DHCP Server is not present;
 - If "Enable DHCP" option is active, it is possible to configure the **"Host Name"** for the Ethernet interface of the converter;

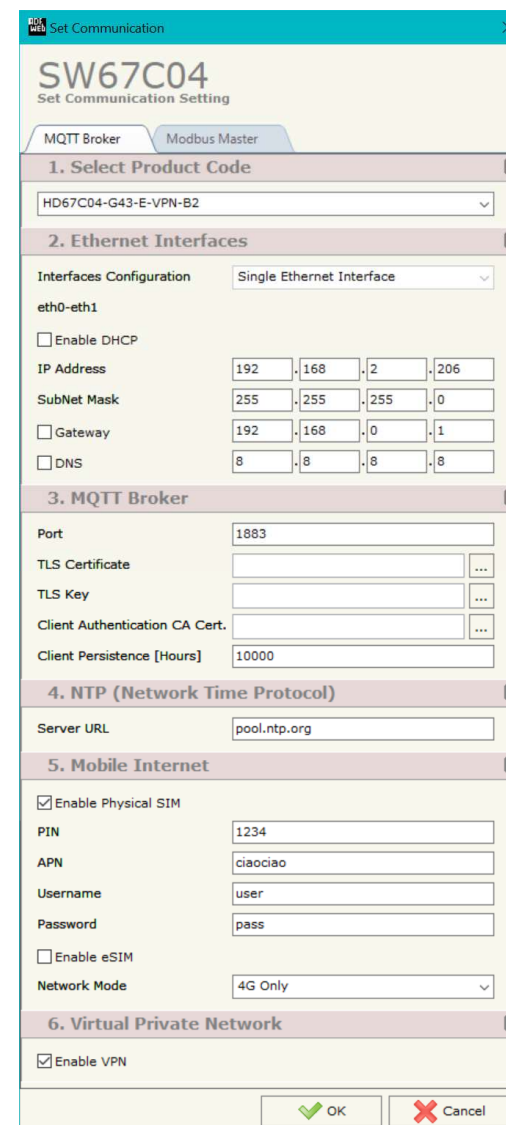

Figure 3a: "Set Communication → MQTT Broker" window

- In the field "**IP Address**", the IP address of the converter is defined;
- In the field "**SubNet Mask**" the Subnet Mask of the converter is defined;
- In the field "**Gateway**" the default gateway of the network is defined. This feature can be enabled or disabled pressing the Check Box field;
- In the field "**DNS**" the IP Address of the DNS server is defined. This feature can be enabled or disabled pressing the Check Box field.

MQTT BROKER → MQTT BROKER:

This section is used to define the general parameters of the MQTT broker. The means of the fields are:

- In the field "**Port**" the TCP port used for MQTT connection is defined;
- In the field "**TLS Certificate**" it is possible to import a certificate for the broker and use TLS protocol;
- In the field "**TLS Key**" it is possible to import the private key of the broker for TLS protocol;
- In the field "**Client Authentication CA Cert.**" it is possible to import the CA certificate used to generate the Certificates and Private keys for the Clients;
- In the field "**Client Persistence [Hours]**" the amount of hours before a Client section expires is defined.

MQTT BROKER → NTP (NETWORK TIME PROTOCOL):

This section is used to define the NTP parameters. The means of the fields are:

- In the field "**Server URL**" the NTP address is defined.

MQTT BROKER → MOBILE INTERNET:

This section is used to define the main parameters of LTE connectivity. The means of the fields are:

- If the field "**Enable Physical SIM**" is checked, the SIM slot is enabled;
- In the field "**PIN**" the PIN code of the SIM card is defined;
- In the field "**APN**" the APN for mobile connection is defined;
- In the field "**Username**" the user for mobile connection is defined;
- In the field "**Password**" the password for mobile connection is defined;
- In the field "**Network Mobile**" it is possible to defined the type of mobile connectivity:
 - All: mobile connection will be automatically managed by the module, selecting the best available network (3G or 4G);

- 4G Only: mobile connection will be done only using LTE;
- If the field "**Enable eSIM**" is checked, the eSIM is enabled (available only for version with integrated eSIM with connectivity enabled).

MQTT BROKER → VIRTUAL PRIVATE NETWORK:

This section is used to define the main parameters for VPN service. The means of the fields are:

- If the field "**Enable VPN**" is checked, the VPN service is enabled (available only for version with VPN service enabled).

Modbus Master section

MODBUS MASTER → MODBUS MASTER:

This section is used to define the general parameters of Modbus side. The means of the fields are:

- In the field "**Serial**" the serial to use is defined;
- In the field "**Baudrate**" the baudrate for the serial line is defined;
- In the field "**Parity**" the parity of the serial line is defined.
- In the field "**Stop Bits**" the number of Stop Bits of the serial line is defined;
- In the field "**TimeOut (ms)**" there is the maximum time that the device attends for the answer from the Slave interrogated;
- In the field "**Cyclic Delay (ms)**" the delay (idle time) between two Modbus requests is defined.

1. Modbus Master	
Serial	RS232
Baudrate	115200
Parity	NONE
Stop Bits	1 Stop Bits
TimeOut (ms)	1000
Cyclic Delay (ms)	100

Figure 3b: "Set Communication → Modbus Master" window

SET MQTT BROKER:

By Pressing the **“Set MQTT Broker”** button from the main window for SW67C04 (Fig. 2) the window **“MQTT Broker”** appears (Fig. 4). This section is used to define the list of the MQTT Clients that can connect to the broker and the list of accepted/denied topics.

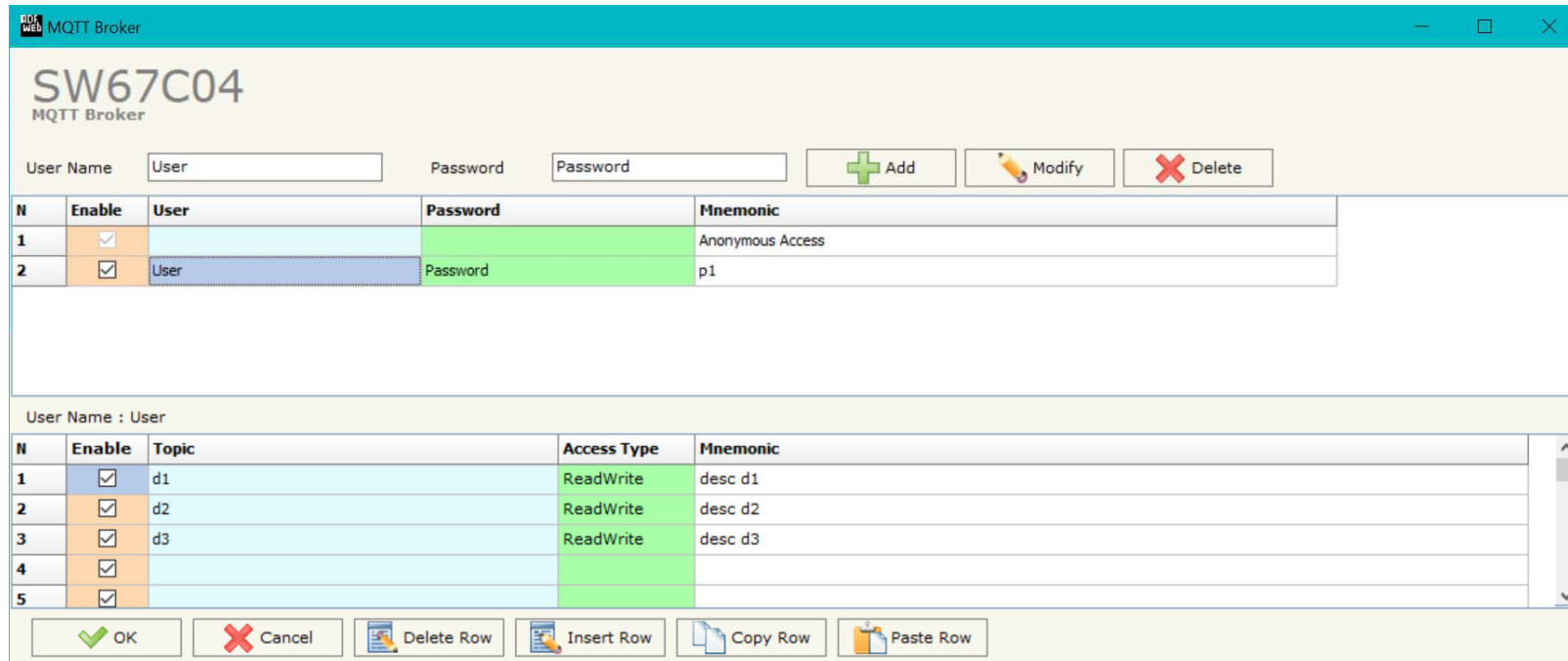

Figure 4: “MQTT Broker” window

In the first table, it is possible to add, modify and delete the MQTT Clients by clicking on “Add”, “Modify” and “Delete buttons”. The means of the fields are:

- If the field **“Enable”** is checked, the MQTT Client is enabled;
- In the field **“User”** the username of the MQTT Client is defined;
- In the field **“Password”** the password of the MQTT Client is defined;
- In the field **“Mnemonic”** a description for the MQTT Client is defined.

In the second table, it is possible create the list of the allowed/denied topics for each MQTT Client created. It is necessary to select the Client from the first table and then edit the topics in the second. The means of the fields are:

- If the field "**Enable**" is checked, the MQTT topic is enabled;
- In the field "**Topic**" the name of the topic is defined;
- In the field "**Access Type**" it is possible to select the access level for the defined topic. It is possible to have:
 - Read: the topic can be only subscribed;
 - Write: the topic can be only published;
 - Read/Write: the topic can be published and subscribed;
 - Deny: the topic is not accessible;
- In the field "**Mnemonic**" a description for the topic is defined.

MQTT SET TOPIC:

By Pressing the **"MQTT Set Topic"** button from the main window for SW67C04 (Fig. 2) the window "Set MQTT Topics" appears (Fig. 4). This section is used to define the MQTT topics that the converter will publish and subscribe. The topics in publish will contain the data written by the Modbus Master, the topics in subscribe will contain the data to be read by the Modbus Master.

MQTT PUBLISH (SENT TO MQTT CLIENTS)

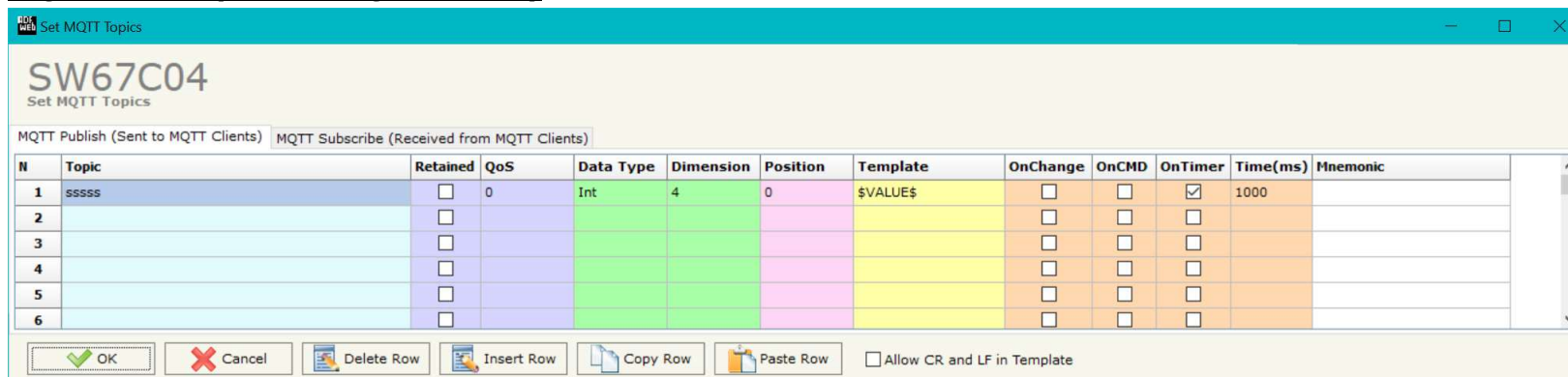

Figure 4a: "Set MQTT Topics → MQTT Publish (Sent to MQTT Clients)" window

The means of the fields are:

- In the field **"Topic"** the MQTT topic is defined;
- If the field **"Retained"** is defined, the retained flag is enabled. The MQTT server will hold the last topic published;
- In the field **"QoS"** the QoS level is defined;
- In the field **"Data Type"** the type of data to use is defined;
- In the field **"Dimension"** the dimension in byte of the data is defined;
- In the field **"Position"** the starting byte of the internal memory array where taking the data is defined;
- In the field **"Template"** the structure of the MQTT payload is defined. With a double click on it, it is possible to open a window for editing it. In order to edit the field, it is possible to use specific Key words described on page XX;
- If the field **"On Change"** is checked, the converter publishes the topic when the data from Modbus are changed;
- If the field **"On CMD"** is checked, the converter publishes the topic when a new request from Modbus is received;
- If the field **"On Timer"** is checked, the converter publishes the topic cyclically with the delay defined in the field **"Time (ms)";**
- In the field **"Mnemonic"** a description of the topic is defined.

MQTT SUBSCRIBE

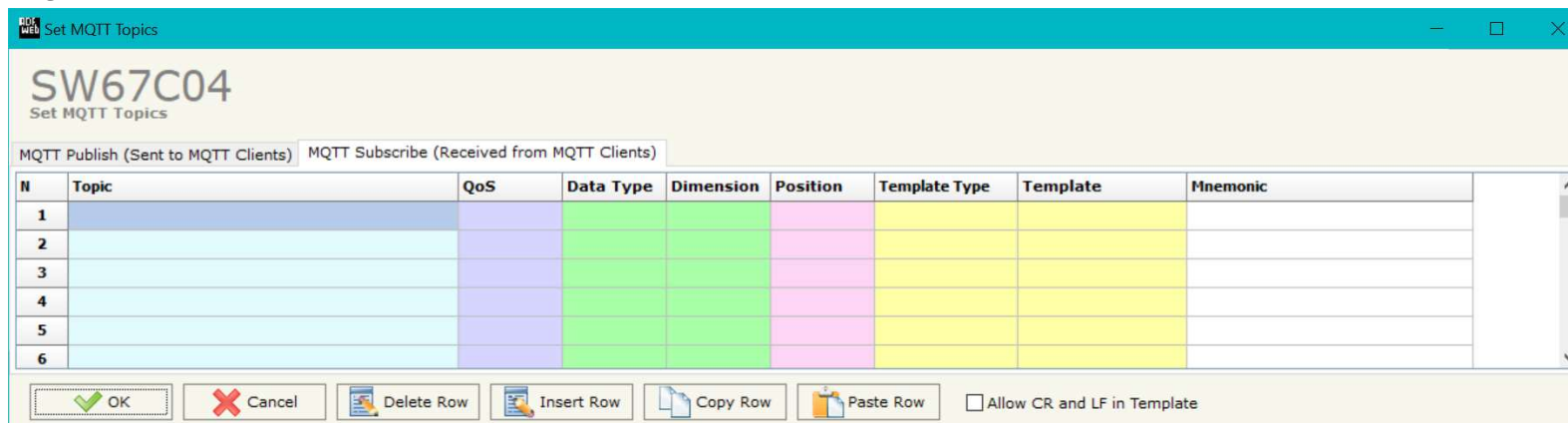

Figure 4b: "Set MQTT Topics → MQTT Subscribe (Received from MQTT Clients)" window

The means of the fields are:

- In the field "**Topic**" the MQTT topic is defined;
- In the field "**QoS**" the QoS level is defined;
- In the field "**Data Type**" the type of data to use is defined;
- In the field "**Dimension**" the dimension in byte of the data is defined;
- In the field "**Position**" the starting byte of the internal memory array where placing the data is defined;
- In the field "**Template Type**" the template format is defined. If the option "RAW" is selected it is managed as plaintext; otherwise if it is selected "JSON" option it is managed as a Json format;
- In the field "**Template**" the structure of the MQTT payload is defined. With a double click on it, it is possible to open a window for editing it. In order to edit the field, it is possible to use specific Key words described on page XX;
- In the field "**Mnemonic**" a description of the topic is defined.

MQTT SET BRIDGES:

By Pressing the **"MQTT Set Bridges"** button from the main window for SW67C04 (Fig. 2) the window "Set MQTT Bridges" appears (Fig. 5). This section is used to define the MQTT connection to an external MQTT broker and link the local topics to the remote topics.

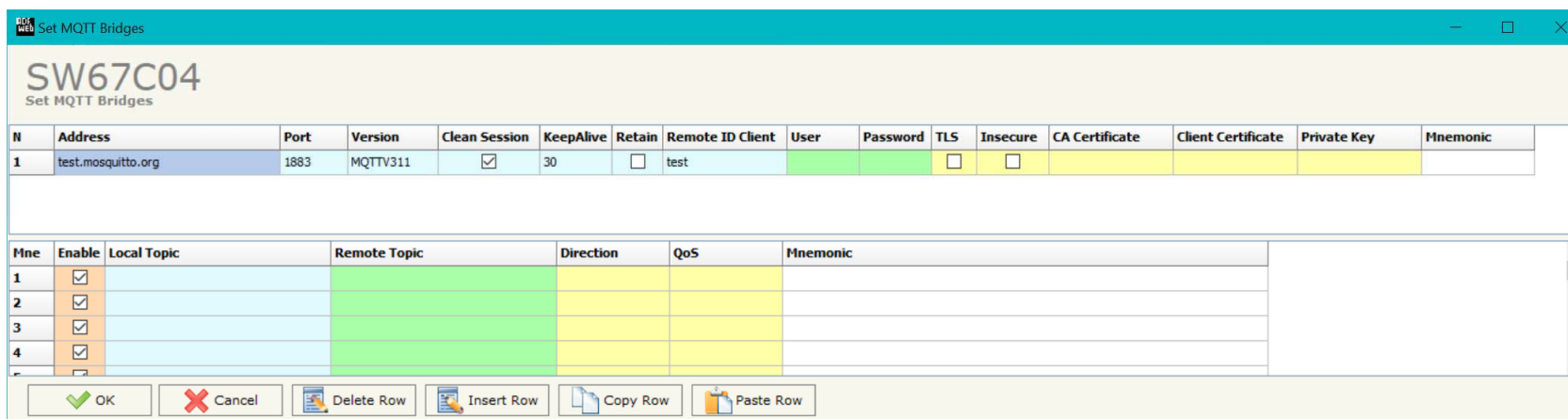

Figure 5: "Set MQTT Bridges → Set MQTT Bridges" window

In the first table, it is possible to define the MQTT connection of the MQTT bridge. The means of the fields are:

- In the field **"Address"** the IP Address or URL of the MQTT broker is defined;
- In the field **"Port"** the TCP port for MQTT connection is defined;
- In the field **"Version"** the version of MQTT protocol is defined;
- If the field **"Clean Session"** is checked, the last MQTT messages are deleted by the Server and the Client in case of missing ACK. If unchecked, the Server and the Client hold the last MQTT messages and, in case of incorrect disconnection or missing ACK, they try to send again them since all the ACK messages are exchanged correctly (valid only for QoS 1 and QoS 2);
- In the field **"KeepAlive"** the delay (in seconds) with which the Keep Alive message is sent on MQTT is defined;
- If the field **"Retain"** is checked, the converter will send the connection topic with Retain flag enabled. In this way, the Server will hold the last Connection message received;
- In the field **"Remote ID Client"** the Client ID of the bridge is defined;
- In the field **"User"** the username for the connection to the MQTT server is defined;
- In the field **"Password"** the password for the connection to the MQTT server is defined;
- If the field **"TLS"** is checked, the TLS protocol for secure connection is enabled;

- If the field "**Insecure**" is checked, the validity of the server certificate will not be verified;
- In the field "**CA Certificate**" the .pem CA Certificate of the remote broker/server used to open a secure connection is defined;
- In the field "**Client Certificate**" the .pem Client's Certificate is defined;
- In the field "**Private Key**" the corresponding .pem Client's Certificate key is defined;
- In the field "**Mnemonic**" a description of the topic is defined.

In the second table, it is possible to create the list of the topics to publish and subscribe to the remote broker. The means of the fields are:

- If the field "**Enable**" is checked, the MQTT topic is enabled;
- In the field "**Local Topic**" the name of the local topic to link to the remote topic is defined;
- In the field "**Remote Topic**" the name of the remote topic to link to the local topic is defined;
- In the field "**Direction**" it is possible to select the allowed access for the defined topic. It is possible to have:
 - IN: the topic can be only subscribed;
 - OUT: the topic can be only published;
 - BOTH: the topic can be published and subscribed.
- In the field "**QoS**" the QoS level is defined;

In the field "**Mnemonic**" a description for the topic is defined.

MODBUS SET ACCESS:

By pressing the “**Modbus Set Access**” button from the main window for SW67C04 (Fig. 2) the window “Set Modbus Access” appears.

This window is divided in two parts, the “Modbus Read” (Fig. 7a) and the “Modbus Write ” (Fig. 7b).

The first part “Modbus Read” is used to read the data from the Modbus slaves and make them available on MQTT side.

The second part “Modbus Write ” is used to write the data that arrives from MQTT side to the Modbus slaves.

MODBUS READ

The means of the fields are:

- If the field “**Enable**” is checked, the Modbus request is enabled;
- In the field “**Slave ID**” the address of the Modbus device to read is defined;
- In the field “**Type**” the data type of the register to read is defined. It is possible to choose between the following:
 - Coil Status;
 - Input Status;
 - Holding Register;
 - Input Register.
- In the field “**Address**” the starting address of the register to be read is defined;
- In the field “**NPoint**” the number of consecutive registers to be read is defined;
- In the field “**Poll Time**” the delay time to make the request is defined;
- In the field “**Max Error**” the number of consecutive errors that the converter waits before suspending the request until the next reboot is defined. If is set to '0' this function is disabled;
- In the field “**Position**” the address of the internal array where placing the information is defined;
- In the field “**Start Bit**” the starting bit of the first byte of the field “Position” is defined;
- If the field “**Swap**” is checked, the data from the Modbus registers are swapped;
- If the field “**SwapWord**” is checked, the Modbus words are swapped;
- In the field “**Mnemonic**” the description for the request is defined.

N	Enable	Slave ID	Type	Address	NPoint	Poll Time	Max Error	Position	Start Bit	Swap	SwapWord	Mnemonic
1	<input checked="" type="checkbox"/>	1	Holding Register	100	4	1000	0	0	0	<input type="checkbox"/>	<input type="checkbox"/>	a1
2	<input checked="" type="checkbox"/>	2	Holding Register	104	1	1500	0	8	0	<input type="checkbox"/>	<input type="checkbox"/>	a2
3	<input checked="" type="checkbox"/>									<input type="checkbox"/>	<input type="checkbox"/>	
4	<input checked="" type="checkbox"/>									<input type="checkbox"/>	<input type="checkbox"/>	
5	<input checked="" type="checkbox"/>									<input type="checkbox"/>	<input type="checkbox"/>	
6	<input checked="" type="checkbox"/>									<input type="checkbox"/>	<input type="checkbox"/>	
7	<input checked="" type="checkbox"/>									<input type="checkbox"/>	<input type="checkbox"/>	
8	<input checked="" type="checkbox"/>									<input type="checkbox"/>	<input type="checkbox"/>	

Figure 6a: “Set Access→Modbus Read”

MODBUS WRITE

The means of the fields are:

- If the field **"Enable"** is checked, the Modbus request is enabled;
- In the field **"Slave ID"** the address of the Modbus device that you have to write is defined;
- In the field **"Type"** the data type of the register to write is defined. It is possible to choose between the following:
 - Coil Status;
 - Holding Register.
- In the field **"Address"** the start address of the register to be written is defined;
- In the field **"NPoint"** the number of consecutive registers to be written is defined;
- In the field **"Poll Time"** the delay time to make the request is defined;
- If the field **"On Change"** is checked, the converter sends the writing request when the data from MQTT side change value;
- If the field **"On CMD"** is checked, the converter sends the writing request when the data from MQTT is received;
- In the field **"Max Error"** the number of consecutive errors that the converter waits before suspending the request until the next reboot is defined. If is set to '0' this function is disabled;
- In the field **"Position"** the address of the internal array where taking the information is defined;
- In the field **"Start Bit"** the starting bit of the first byte of the field "Position" is defined;
- If the field **"Swap"** is checked, the data written the Modbus registers are swapped;
- If the field **"SwapWord"** is checked, the Modbus words are swapped;
- In the field **"Mnemonic"** the description for the request is defined.

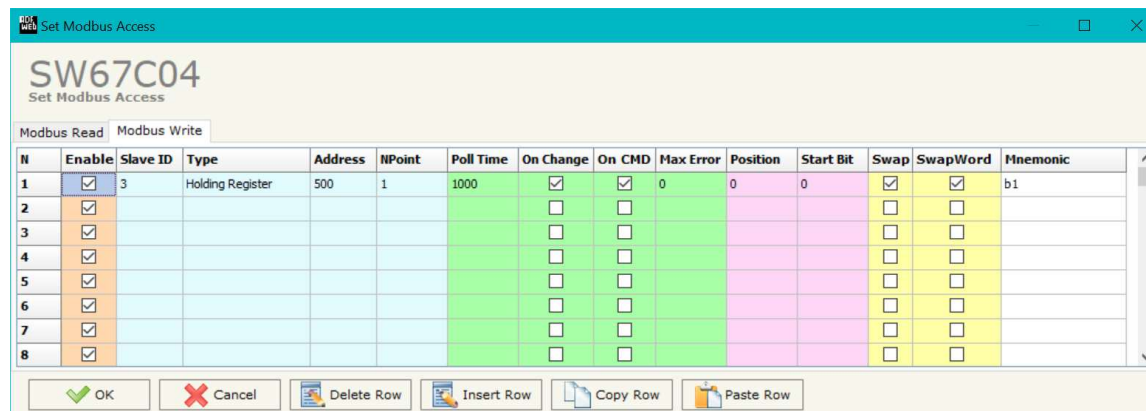

Figure 6b: "Set Access → Modbus Write" window

UPDATE DEVICE:

By pressing the **"Update Device"** button, it is possible to load the created Configuration into the device; and also the Firmware, if necessary. This by using the Ethernet port.

If you don't know the actual IP address of the device you have to use this procedure:

- Turn ON the device
- Connect the Ethernet cable;
- Insert the IP Address of the converter (if not known, it is possible to use "ADFweb Discovery Tool" to find it);
- Press the **"Execute update firmware"** button to start the upload;
- When all the operations are "OK" turn OFF the Device;
- Close the updating windows and wait for restarting.

At this point the configuration/firmware on the device is correctly updated.

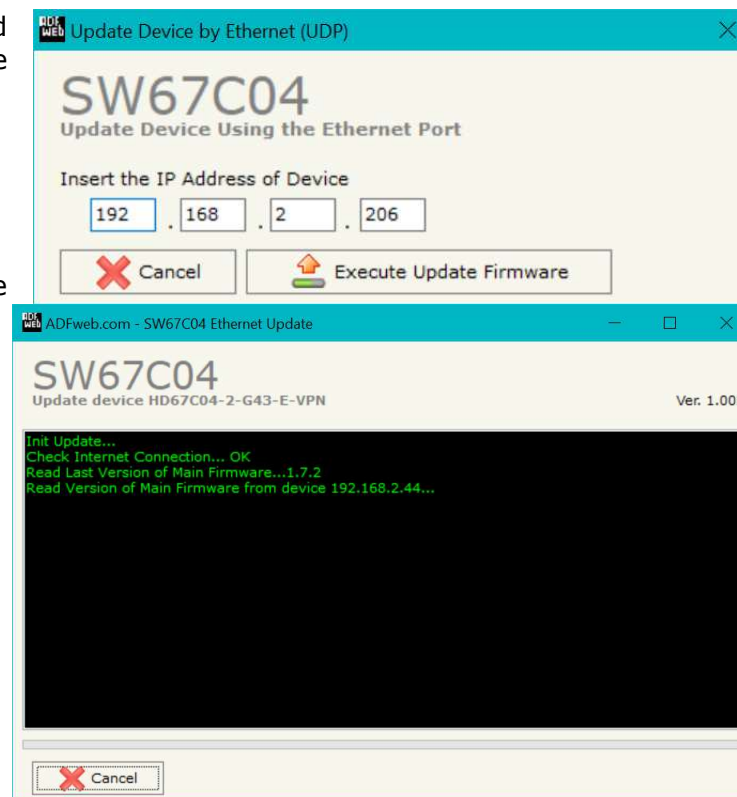

Figure 7: "Update device" windows

**Warning:**

If the update fails, try these points before seeking assistance:

- Try to repeat the operations for the updating;
- Try with another PC;
- Try to restart the PC;
- Check the LAN settings;
- If you are using the program inside a Virtual Machine, try to use in the main Operating System;
- If you are using Windows Seven, Vista, 8, 10 or 11 make sure that you have the administrator privileges;
- In case you have to program more than one device, using the "UDP Update", you have to cancel the ARP table every time you connect a new device on Ethernet. For do this you have to launch the "Command Prompt" and write the command "arp -d". Pay attention that with Windows Vista, Seven, 8, 10, 11 you have to launch the "Command Prompt" with Administrator Rights;
- Pay attention at Firewall lock.

**Warning:**

In the case of HD67C04 you have to use the software "SW67C04": www.adfweb.com/download/filefold/SW67C04.zip.

USER/PASSWORD:

Change User Password

SW67C04
Change User Password

Attention! The Software does not save the User and Password
The Default Values are admin/admin

Old User New User

Old Password New Password

Ip Address

Figure 7: "Change User Password"

By pressing the "**USER/PASSWORD**" button, it is possible to change the User and Password credentials for the update of the device. The default credentials are "admin" for User and Password.

**Warning:**

If you don't remember the User and Password that you have set, it is necessary to reset the device on factory settings using the recovery button. The configuration inside the converter will be lost.

TEMPLATE STRING: DEFINITION OF MQTT PAYLOAD

Mode 1: mapping a single variable for each topic using tables

In this mode, it is possible to define which is the Modbus data to map inside the MQTT topics using the Position field inside "MQTT Set Topic" section. This simplifies the configuration because the variable to be mapped is selected using the table, but it allows you to map a single variable for each topic.

In order to link the data into the MQTT topic, you can use the keyword \$VALUE\$. The keyword will be replaced with the real value coming from/to Modbus.

Mode 2: mapping more variables for each topic using keywords

In this mode, it is possible to define which is the Modbus data to map inside the MQTT topics specific keywords. Position field, format and dimension of "MQTT Set Topic" section will be ignored.

In order to link the data into the MQTT topic, you can use these keywords:

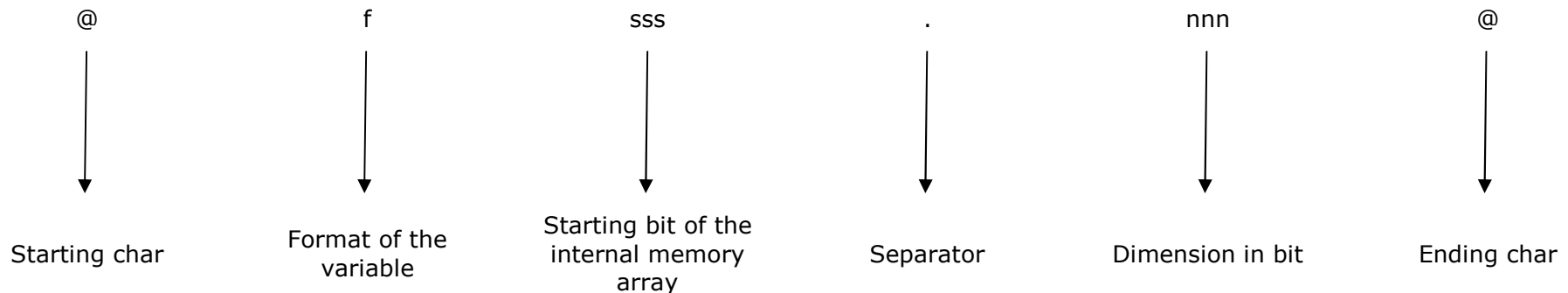

Below the type of format allowed:

FORMAT	IDENTIFIER
Unsigned Integer	u
Signed Integer	i
Float	f
Binary	b
String	s
Hexadecimal	x
Base64	l

Example:

We have two variables mapped respectively into Position 0 and 4. The first one is an signed integer value of 16 bit, the second one is a floating point. In order to compose a JSON, the template can be filled in this way:

```
{
  "var1": @i0.16@,
  "var2": @f32.32@
}
```



Note:

It is not possible to use both modes in the template.

MECHANICAL DIMENSIONS:

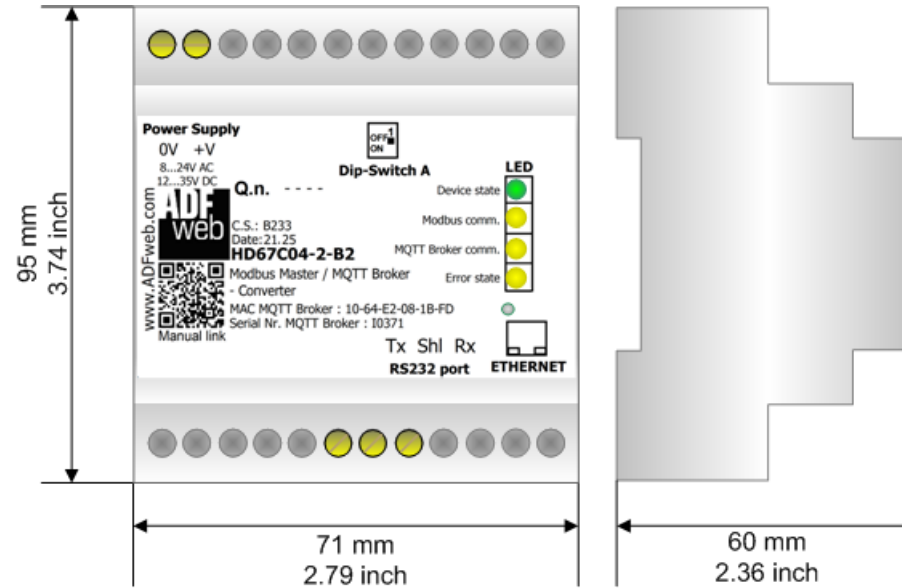

Housing: PVC
Weight: 200g (Approx)

Figure 8a: Mechanical dimensions scheme for HD67C04-2-B2

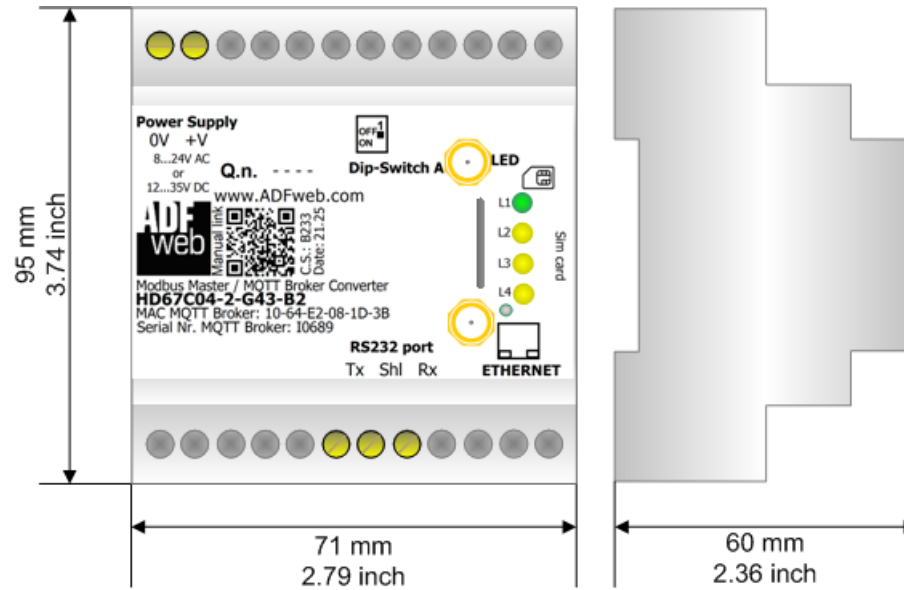

Housing: PVC
Weight: 200g (Approx)

Figure 8b: Mechanical dimensions scheme for HD67C04-2-G43-x-xxx-B2

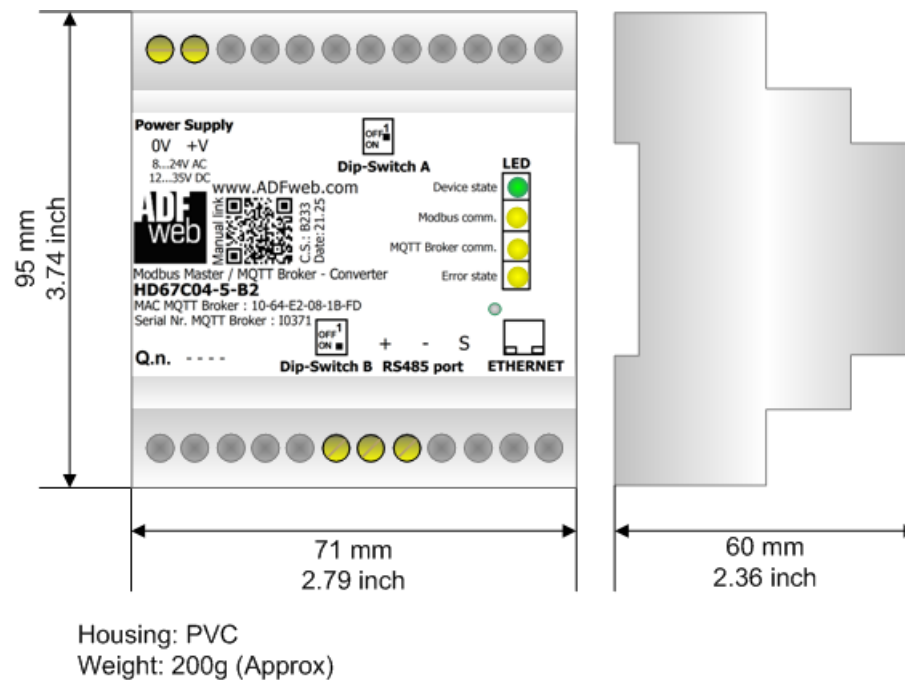
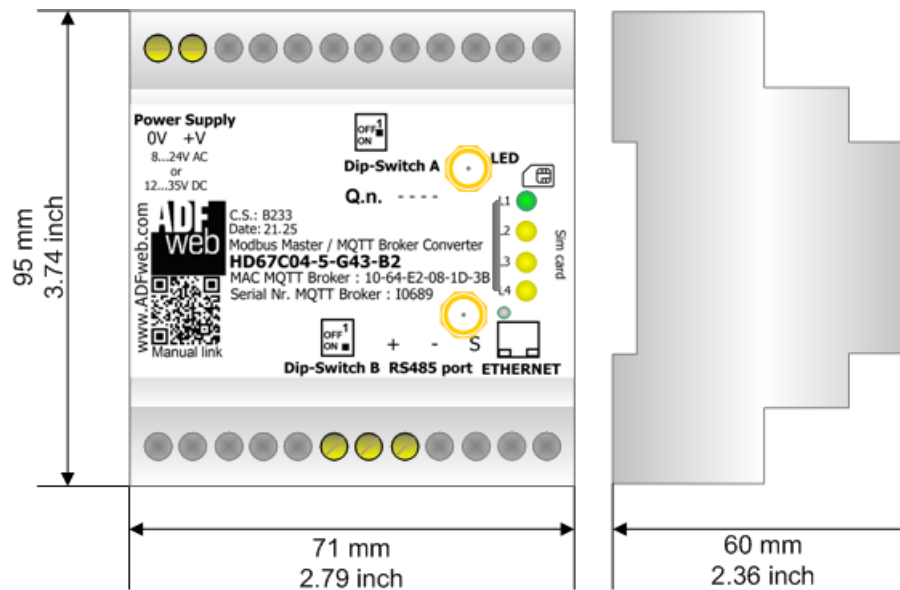

Figure 8c: Mechanical dimensions scheme for HD67C04-5-B2



Housing: PVC
Weight: 200g (Approx)

Figure 8d: Mechanical dimensions scheme for HD67C04-5-G43-x-xxx-B2

ORDERING INFORMATIONS:

The ordering part number is formed by a valid combination of the following:

HD67C04 - x - xxx - x - xxx - B 2

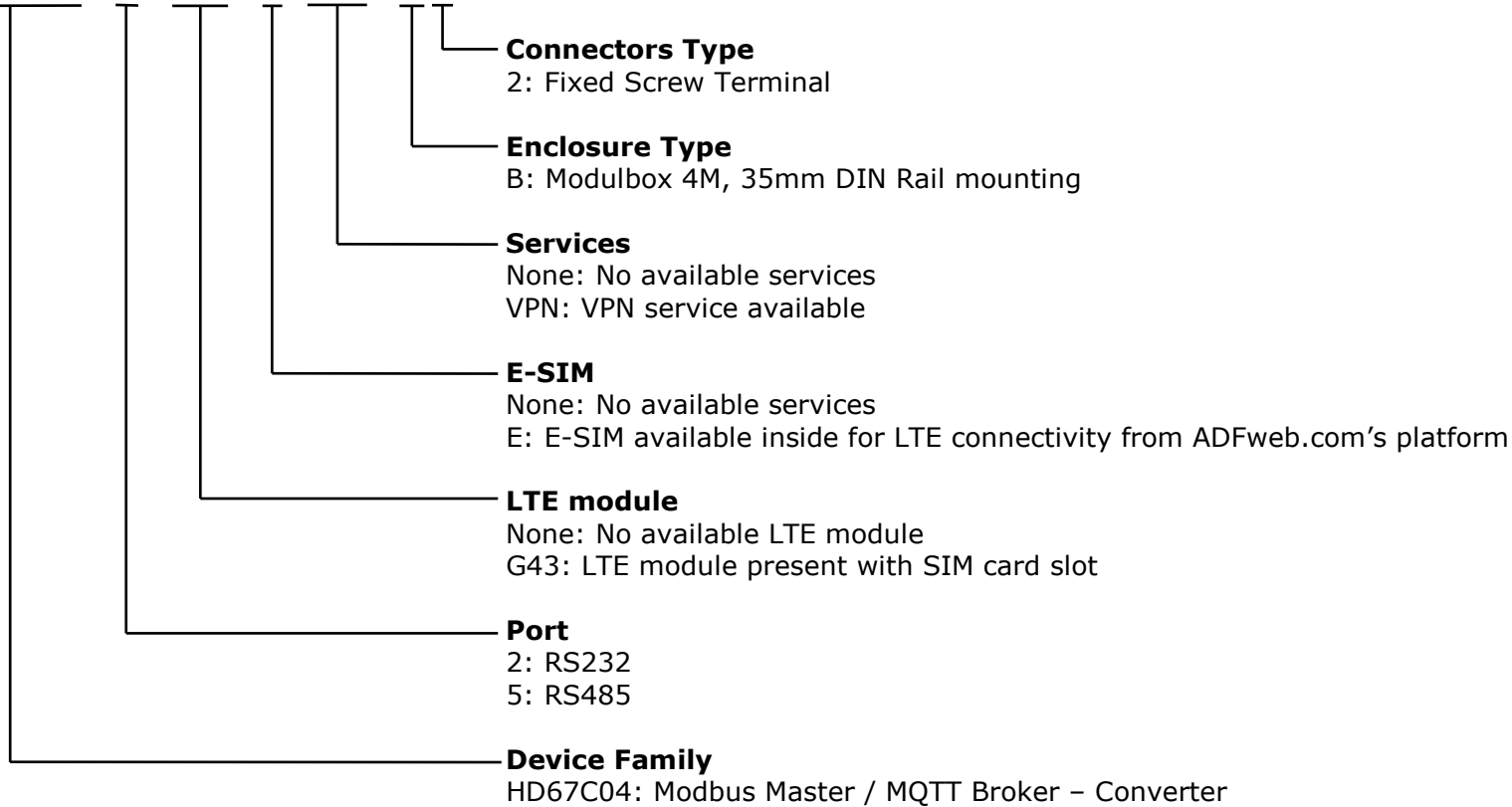

- Order Code: **HD67C04-2-B2** - Modbus Master / MQTT Broker – Converter
- Order Code: **HD67C04-2-G43-B2** - Modbus Master / MQTT Broker – Converter (LAN + SIM LTE)
- Order Code: **HD67C04-2-G43-E-B2** - Modbus Master / MQTT Broker – Converter (LAN + SIM LTE+E-SIM)
- Order Code: **HD67C04-2-G43-VPN-B2** - Modbus Master / MQTT Broker – Converter (LAN + SIM LTE, VPN)
- Order Code: **HD67C04-2-G43-E-VPN-B2** - Modbus Master / MQTT Broker – Converter (LAN + SIM LTE+E-SIM, VPN)

- Order Code: **HD67C04-5-B2** - Modbus Master / MQTT Broker – Converter
- Order Code: **HD67C04-5-G43-B2** - Modbus Master / MQTT Broker – Converter (LAN + SIM LTE)
- Order Code: **HD67C04-5-G43-E-B2** - Modbus Master / MQTT Broker – Converter (LAN + SIM LTE+E-SIM)
- Order Code: **HD67C04-5-G43-VPN-B2** - Modbus Master / MQTT Broker – Converter (LAN + SIM LTE, VPN)
- Order Code: **HD67C04-5-G43-E-VPN-B2** - Modbus Master / MQTT Broker – Converter (LAN + SIM LTE+E-SIM, VPN)

ACCESSORIES:

- Order Code: **AC34011** - 35mm Rail DIN - Power Supply 220/240V AC 50/60Hz – 12 V DC
- Order Code: **AC34012** - 35mm Rail DIN - Power Supply 220/240V AC 50/60Hz – 24 V DC

DISCLAIMER:

All technical content within this document can be modified without notice. The content of the document is a under continual renewal. For losses due to fire, earthquake, third party access or other accidents, or intentional or accidental abuse, misuse, or use under abnormal conditions repairs are charged to the user. ADFweb.com S.r.l. will not be liable for accidental loss of use or inability to use this product, such as loss of business income. ADFweb.com S.r.l. shall not be liable for consequences of improper use.

OTHER REGULATIONS AND STANDARDS:**WEEE INFORMATION**

Disposal of old electrical and electronic equipment (as in the European Union and other European countries with separate collection systems).

— This symbol on the product or on its packaging indicates that this product may not be treated as household rubbish. Instead, it should be taken to an applicable collection point for the recycling of electrical and electronic equipment. If the product is disposed correctly, you will help prevent potential negative environmental factors and impact of human health, which could otherwise be caused by inappropriate disposal. The recycling of materials will help to conserve natural resources. For more information about recycling this product, please contact your local city office, your household waste disposal service or the shop where you purchased the product.

RESTRICTION OF HAZARDOUS SUBSTANCES DIRECTIVE

The device respects the 2002/95/EC Directive on the restriction of the use of certain hazardous substances in electrical and electronic equipment (commonly referred to as Restriction of Hazardous Substances Directive or RoHS).

CE MARKING

The product conforms with the essential requirements of the applicable EC directives.

WARRANTIES AND TECHNICAL SUPPORT:

For fast and easy technical support for your ADFweb.com SRL products, consult our internet support at www.adfweb.com.
Otherwise contact us at the address support@adfweb.com

RETURN POLICY:

If while using your product you have any problem and you wish to exchange or repair it, please do the following:

- Obtain a Product Return Number (PRN) from our internet support at www.adfweb.com. Together with the request, you need to provide detailed information about the problem.
- Send the product to the address provided with the PRN, having prepaid the shipping costs (shipment costs billed to us will not be accepted).

If the product is within the warranty of twelve months, it will be repaired or exchanged and returned within three weeks. If the product is no longer under warranty, you will receive a repair estimate.



ADFweb.com S.r.l.
Via Strada Nuova, 17
IT-31010 Mareno di Piave
TREVISO (Italy)
Phone +39.0438.30.91.31
Fax +39.0438.49.20.99
www.adfweb.com

