



IAP3300L-2E-4GT1GP-2LVI

DIN-Rail or Wall Mounting

Indoor Dual Band WiFi6 Wireless AP

- Support two 2.4G/5G antenna interfaces, 4 Gigabit RJ45 ports (LAN) and 1 Gigabit PoE RJ45 port (LAN/WAN)
- Support WiFi6 (802.11ax), which can improve system capacity and concurrent access, and reduce transmission delay.
- Support multiple network modes such as routing, AP, bridge and client mode.
- Support IEEE802.3at/af PoE power supply input and 12~48VDC power supply input
- Support -40~55°C wide operating temperature range



Introduction

IAP3300L-2E-4GT1GP-2LVI is 5-port full Gigabit indoor dual band WiFi6 wireless AP, the PoE power supply conforms to IEEE802.3af/at protocol standard. This product provides 2.4G/5G combined antenna interface, Gigabit RJ45 port (LAN) and Gigabit PoE RJ45 port (LAN/WAN) and other interfaces, and supports DIN-rail or wall mounting, which can meet the needs of different application sites.

The management system supports route, AP, bridge, client, dual-link and other work modes; Support IEEE802.11a/b/g/n/ac/ax wireless technology, the wireless rate of the whole device is up to 1774.5Mbps; The device supports wireless encryption methods such as WPA/WPA2/WPA3, and has various security policies such as SSID hiding, wireless user isolation, IP address filtering, MAC address filtering, port forwarding, port redirection, ARP binding, DMZ setting, etc. Support virtual AP, that is, one AP device supports multiple SSIDs.

DIP switch can achieve restore factory defaults of the device. Hardware adopts fanless, low power consumption, wide temperature and voltage design and has passed rigorous industrial standard tests, which can adapt to the industrial scene environment with harsh requirements for EMC. All components are industrial grade with protection grade of IP40. It can be widely used in the scenes such as AGV cars, industrial robots, intelligent warehousing in factory automation, petrochemical industry, power monitoring and so on.

Features and Benefits

- ⦿ Support modes like routing mode, AP mode, bridge mode, client mode and dual-link mode, support connection methods like WDS and universal bridge
- ⦿ The client mode supports wireless NAT connection, and the wireless network can connect with the external network through PPPoE, static IP and DHCP dynamic acquisition, and implement route switch
- ⦿ Support high-speed wireless connection, the transmission speed of 2.4GHz can reach up to 573.5Mbps, the transmission speed of 5GHz can reach up to 1201Mbps
- ⦿ Support 2 2.4G/5G WiFi antenna interfaces
- ⦿ Support wireless probe, it can realize personal positioning function with location engine
- ⦿ Support SNMP network management and Trap alarm
- ⦿ Support multiple SSID settings and provide SSID hiding function
- ⦿ Support WPA/WPA2/WPA3 wireless encryption method of both personal edition and enterprise edition and TKIP/AES encryption algorithm
- ⦿ AC management can specify AC device information to realize directional management
- ⦿ Roaming proxy can realize roaming proxy host across network segments, effectively avoiding the data interruption caused by the failure to update the forwarding list of upper-level device in time
- ⦿ Support IP filtering, MAC filtering, URL filtering, port forwarding, port redirection, ARP

- binding, DMZ isolation area and other firewall functions
- Support wireless user management and user event, and support blacklist and whitelist filtering rules, wireless user online/offline notification
- WMM can achieve better transmission quality of voice, video and other applications in wireless networks
- Network detection can realize network diagnosis and specific network recovery operations

Dimension

Unit: mm

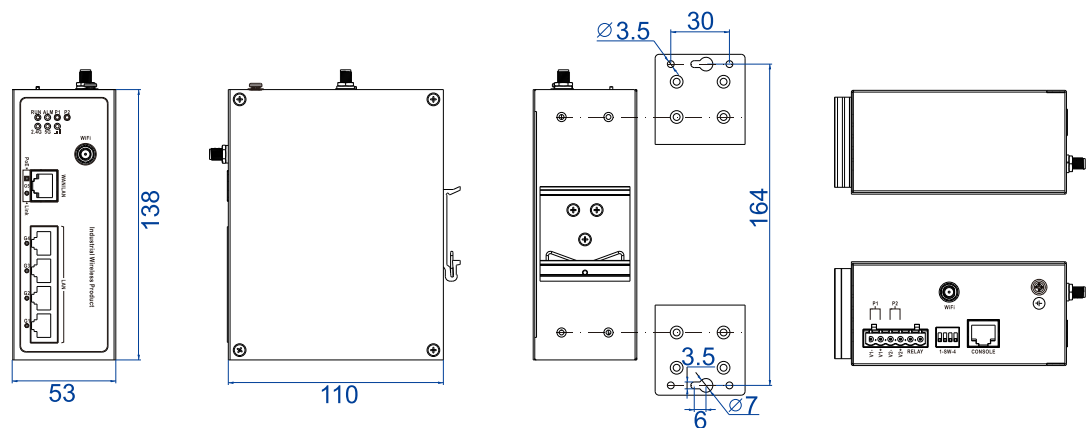

Specification

<p>Standard & Protocol</p>	<p>IEEE 802.3 for 10Base-T IEEE802.3u for 100Base-TX IEEE 802.3ab for 1000Base-T IEEE802.11a/b/g/n/ac/ax for WLAN IEEE802.11i for wireless security IEEE802.11r for fast roaming IEEE802.11e for WMM IEEE802.3af for PoE IEEE802.3at for PoE+</p>
---------------------------------------	---

- Working Mode**
- Routing mode (WAN: PPPoE dial-up, static IP, DHCP dynamic IP acquisition)
 - AP mode (LAN: static IP, DHCP dynamically acquiring IP)
 - Bridge mode (connection: WDS bridge, universal bridge; point-to-point, roaming)
 - Client mode (connection: WDS bridge, universal bridge, wireless NAT;

point-to-point, efficient roaming)
 Dual-link mode (connection: WDS bridge, Dual-universal bridge,
 Dual-wireless NAT; Seamless roaming)

WLAN	WAP/WAP2/WAP3 personal/enterprise edition encryption mode, hidden wireless SSID, wireless user isolation, wireless transmission power adjustment, maximum user limit, RTS threshold, China/US wireless channel, WMM
Management	System state, network status, wireless state, device state, ARP table, routing table, intranet settings, extranet settings, wireless settings, AC management, SNMP management, QoS management, AP roaming control, roaming agent, user settings, system upgrade, timed restart, profile update, system log, wireless user list, and Wi-Fi real-time traffic monitoring, log management, time settings, access settings and diagnostic tools
Security Policy	Wireless user black/white list, wireless user event notice, IP filtering, MAC filtering, URL filtering, port forwarding, port redirection, ARP binding, DMZ settings, access settings
Routing/Switching	Static routing (routing mode, wireless NAT)
Location Service	Wireless probe
Troubleshooting	Network detection, Ping test, route tracing
Time Management	NTP Client
Radio Frequency	802.11b/g/n/ax: 2.412GHz~2.4835GHz 802.11a/n/ac/ax: 5.18GHz~5.825GHz RF power output: 27dBm Modulation methods: DBPSK, DQPSK, CCK, OFDM, 16-QAM, 64-QAM, 256-QAM, 1024QAM
Receiving Sensitivity	802.11b: -87dBm@1Mbps, -76dBm@11Mbps 802.11g/a: -82dBm@6Mbps, -65dBm@54Mbps 802.11n: -82dBm@MCS0, -64dBm@MCS7 802.11ac: -82dBm@MCS0, -57dBm@MCS9 802.11ax: -82dBm@MCS0, -52dBm@MCS11
Transmitting Power	802.11b: 24dBm@1Mbps, 20dBm@11Mbps 802.11g/a: 24dBm@6Mbps, 20dBm@54Mbps 802.11n: 24dBm@MCS0, 20Bm@MCS7 802.11ac: 24dBm@MCS0, 20Bm@MCS9

802.11ax: 24dBm@MCS0, 20Bm@MCS11

<p>Interface</p>	<p>Gigabit RJ45 port (LAN): 4 10/100/1000Base-T(X) self-adaptive RJ45 LAN port, support automatic flow control, full/half duplex mode, MDI/MDI-X self-adaption</p> <p>Gigabit RJ45 port (LAN/WAN): 1 10/100/1000Base-T(X) self-adaptive RJ45 LAN/WAN port, supports automatic flow rate control, full/half duplex, MDI/MDI-X self-adaption; supports IEEE802.3af/at standard PoE power input</p> <p>Antenna interfaces: 2 2.4/5G combined antenna interfaces, adopting RPSMA-K connector</p> <p>Console port: CLI command management port(RS-232)</p> <p>Relay (Reserved): one relay output, and adopts 6-pin 5.08mm pitch terminal blocks, with the relay occupying two pins</p>
<p>Power Supply</p>	<p>Gigabit PoE RJ45 port: supports IEEE802.3af/at standard, PoE 48VDC power input</p> <p>Power supply terminal: 12~48VDC power input, support non-polarity, using 6-pin 5.08mm pitch terminal blocks, with power supply occupies 4 pins</p>
<p>Indicator</p>	<p>Running indicator, alarm indicator, power indicator, 2.4G indicator, 5.8G indicator, 2.4G/5G bridge signal strength indicator, WAN indicator, LAN indicator, PoE indicator</p>
<p>Power Consumption</p>	<ul style="list-style-type: none"> ● Normal temperature No-load 9.2w@12VDC, 8.3w@24VDC, 8.2w@36VDC, 8.8w@48VDC ● Normal temperature full load 21.6w@12VDC, 18.0w@24VDC, 19.0w@36VDC, 18.7w@48VDC ● High temperature full load 22.3w@12VDC, 19.0w@24VDC, 18.7w@36VDC, 18.9w@48VDC
<p>Working Environment</p>	<p>Operating temperature: -40~55°C</p> <p>Storage temperature:-40~85°C</p> <p>Relative humidity: 5% ~ 95% (no condensation)</p>
<p>Physical Characteristic</p>	<p>Housing: IP40 protection grade</p> <p>Installation: DIN-Rail or wall mounting</p> <p>Dimension (W x H x D): 53mm×138mm×110mm</p> <p>Weight: 741g</p>
<p>Industrial Standard</p>	<p>IEC 61000-4-2 (ESD, electrostatic discharge), Level 3</p>

- Air discharge: $\pm 8\text{kV}$
- Contact discharge: $\pm 6\text{kV}$

IEC 61000-4-4 (EFT, electrical fast transient pulses), Level 3

- Power supply: $\pm 2\text{kV}$
- Ethernet port: $\pm 1\text{kV}$

IEC 61000-4-5 (Surge), Level 3

- Power supply: common mode $\pm 2\text{kV}$, differential mode $\pm 1\text{kV}$
- Ethernet port: $\pm 2\text{kV}$

Shock: IEC 60068-2-27

Free fall: IEC 60068-2-32

Vibration: IEC 60068-2-6

Authentication

CE, FCC, RoHS

Warranty

5 years

Ordering Information

Available Models	Antenna Interface 2.4G/5G	Gigabit RJ45 LAN Port		Power Input
		LAN	PoE LAN/WAN	
IAP3300L-2E-4GT1GP-2LVI	2	4	1	PoE 48VDC or 12~48VDC dual power input

Accessory Information

Type	Gain (dBi)	Count (pcs)	Remark
2.4G/5G combined antenna	3	2	Standard



Address: 3/B, Zone 1, Baiwangxin High Technology Industrial Park, Song Bai Road,
Nanshan District, Shenzhen, 518108, China

TEL.: +86-755-26702668 ext 835 FAX: +86-755-26703485

E-mail: ics@3onedata.com

Website: www.3onedata.com

◀ Please scan our QR code for more details

*Product pictures and technical data in this datasheet are only for reference. Updates are subject to change without prior notice. The final interpretation right is reserved by 3onedata.