



TNS5800B-16T4GT-P24

Wall Mounting

20-Port Layer 3 Public Transportation ITxPT Industrial Ethernet Switch

- Complies with ITxPT
- Support power ignition, support power delay-off
- Support 16 100M M12 interfaces and 4 gigabit M12 interfaces (with 1 pair of Bypass function)
- Adopt Ring patented technology, support single ring, coupling ring, chain, Dual-homing function
- Support 24VDC (12~31.2VDC) power supply input
- Support IP67 protection grade
- Support -40~75°C wide operating temperature range



Introduction

TNS5800B-16T4GT-P24 products are layer 3 industrial Ethernet switches. This product has passed ITxPT certification and is suitable for operation in harsh environments, ensuring the reliability and efficiency of public transportation networks. Ethernet interfaces use firm and reliable M12 connectors which can adapt to usage scenario with vibration and shock. This product supports 24VDC power supply input and adopts wall mounting, which can meet the needs of different application sites.

The network management system supports various network protocols and industry standards, such as static routing, RIP, VRRP, NAT, STP/RSTP/MSTP, ERPS, 802.1Q VLAN, QoS function, DHCP Server, IGMP Snooping, LLDP, port trunking, port mirroring, etc. It also possesses complete management functions, support port configuration, port statistics, port IP binding, access control, 802.1X authentication, network diagnosis, rapid configuration, online upgrade, etc.; CLI, WEB, Telnet, SNMP, SSH and other access methods can be supported. Network management system could bring you great user experience through its friendly interface design and easy and convenient operation.

When port has link failure, ALARM indicator will be bright and send out alarm, meanwhile, alarm device connected to the relay will send out alarm for rapid scene troubleshooting. The hardware adopts fanless, low power consumption and wide temperature design, and the external heat sink provides extraordinary heat dissipation performance. This device has passed rigorous industrial standard tests, which can suit for the industrial scene environment with harsh requirements for EMC. It can be widely used in Bus, Tram and other public transportation on-board systems, primarily used for electronic ticketing, passenger counting, passenger information, and video surveillance systems.

Features and Benefits

- ⦿ SNMPv1/v2c/v3 is used for network management of various levels
- ⦿ RMON can be used for efficient and flexible network monitoring
- ⦿ QoS supports real-time traffic classification and priority setting
- ⦿ LLDP can achieve automatic topology discovery, which is convenient for visual management
- ⦿ DHCP server and DHCP client could be used for allocating IP address of different strategies
- ⦿ DHCP Snooping can ensure DHCP client gets IP address from legal DHCP server
- ⦿ DHCP relay function can realize IP address, gateway, DNS configuration cross network segment
- ⦿ File management is convenient for the device rapid configuration and online upgrading
- ⦿ Log information and log server can record user operation, system failure, system security and other information locally and remotely
- ⦿ User privilege classification configuration can set user privilege level

- 
- ⊙ ACL can enhance the flexibility and security of the network, supporting bidirectional ACL IN and OUT.
 - ⊙ SSH configuration and HTTPS configuration can improve device's management security and guarantee data access security
 - ⊙ Ring, MRP, STP/RSTP/MSTP can achieve network redundancy, preventing network storm
 - ⊙ EPRS function can realize link backup and improve the reliability of network
 - ⊙ Relay alarm is convenient for troubleshooting of construction site
 - ⊙ Storm suppression can restrain broadcast, unknown multicast and unicast
 - ⊙ VLAN is used for simplifying network planning
 - ⊙ Port Trunking and LACP can increase network bandwidth and enhance the reliability of network connection to achieve optimum bandwidth utilization
 - ⊙ IGMP/MLD Snooping can be used for filtering multicast traffic to save the network bandwidth
 - ⊙ IGMP/MLD can be used to manage and maintain multicast members
 - ⊙ ARP could be used for MAC address resolution
 - ⊙ VRRP, RIP/RIPng, ISIS, OSPF/OSPFv3 and BGP can realize dynamic routing configuration
 - ⊙ PIM-DM and PIM-SM can be used to create and maintain multicast routing table entries and realize multicast routing forwarding
 - ⊙ NAT maps private IP address to the legal IP address of external network, which can slow the consumption of IP address space
 - ⊙ Loop detection could efficiently eliminate the influence caused by port loopback by detecting the existence of loopback
 - ⊙ IPDT can track IP device status and realize interaction with other applications
 - ⊙ QinQ can expand VLAN space and realize the transparent transmission of private network VLAN to public network.
 - ⊙ Smart Link link backup, providing reliable and efficient backup and fast switching mechanism
 - ⊙ Conduct network diagnosis and troubleshooting via Ping, Traceroute and cable diagnosis
 - ⊙ Port mirroring can conduct data analysis and monitoring, which is convenient for online debugging

Dimension

Unit: mm

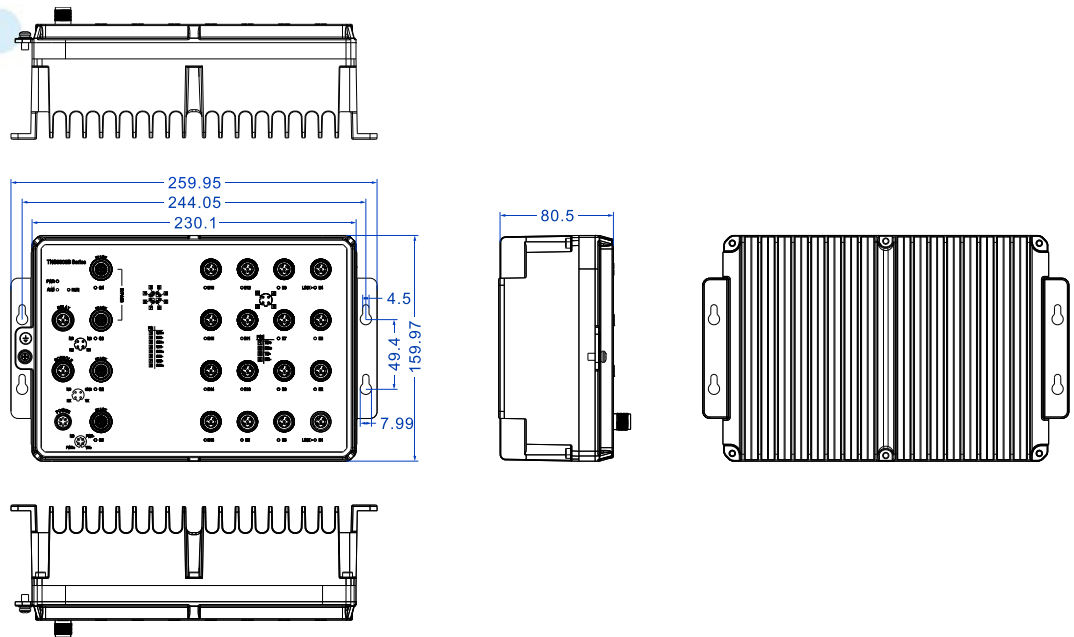

Specification

<p>Standard & Protocol</p>	<p>IEEE 802.3 for 10Base-T IEEE 802.3u for 100Base-TX IEEE 802.3ab for 1000Base-T IEEE 802.3x for Flow Control IEEE 802.1D for Spanning Tree Protocol IEEE 802.1w for Rapid Spanning Tree Protocol IEEE 802.1s for Multiple Spanning Tree Protocol IEEE 802.1Q for VLAN IEEE 802.1p for CoS IEEE 802.1AB for LLDP ITU-T G.8032 for ERPS IEEE 802.3ad for LACP</p>
<p>Management</p>	<p>SNMP v1/v2c/v3 centralized managed equipment, RMON, Port Mirroring, LLDP, DHCP Server, DHCP Relay, port speed limit, port isolation, port statistics, DNS, configuration file management, online upgrade, log information, Syslog server</p>
<p>Security</p>	<p>User permission classification, ACL, 802.1X authentication, DHCP Snooping, Radius server authentication, SSH/HTTPS protocol authorization, link oscillation protection, port loop detection, access control, SNMP, RMON, IPDT, IPv6DT, Smart-Link, NAT, Port alarm, temperature alarm, network load alarm</p>

Switch Function	802.1Q VLAN, MAC, QinQ, static aggregation, LACP, ARP, storm suppression
Unicast / Multicast	IGMP-Snooping, MLD-Snooping, IGMP, MLD, PIM-SM, PIM-DM, IPv6-PIM-SM, IPv6-PIM-DM
Redundancy Technology	Ring, MRP, STP/RSTP/MSTP, ERPS
Routing Technique	RIP, RIPng, OSPF, OSPFv3, ISIS, VRRP, IPv6 VRRP, BGP
Troubleshooting	Ping, Traceroute, Network Cable Diagnosis
Time Management	NTP Client, RTC
Interface	<p>Gigabit M12: 10/100/1000Base-T(X), M12(Female), 8-Pin X-Coded, Automatic Flow Control, Full/half Duplex Mode, MDI/MDI-X Autotuning; it supports 1 pair of Bypass</p> <p>100M M12: 10/100Base-T(X), M12(Female), 4-Pin D-Coded, Automatic Flow Control, Full/half Duplex Mode, MDI/MDI-X Autotuning</p> <p>Alarm interface: M12(Female), 4-Pin D-Coded, support 1 relay alarm output, with current load capacity of 1A@30VDC or 0.3A@125VAC</p> <p>Console port: CLI command line management port (RS-232), M12(Female), 4-Pin D-Coded</p>
Indicator	Power indicator, alarm indicator, running indicator, interface indicator
Switch Property	<p>Transmission mode: store and forward</p> <p>MAC address: 16K</p> <p>Cache: 12Mbit</p> <p>Backplane bandwidth: 128Gbps</p> <p>Switch time delay: <10μs</p>
ITxPT	<p>Ignition Wake-up: The switch does not start immediately upon powering on. It waits until the vehicle's ignition is turned on with the key, and the switch receives the ignition signal before it activates.</p> <p>Delayed Shutdown: After the vehicle's ignition is turned off and the key is removed, the switch continues to operate for a period before powering off.</p> <p>Inventory Service: Provides foundational services compliant with the ITxPT standard.</p> <p>ITxPT xStatus: Provides status reports, fault information, and other</p>

	details of Inventory Service devices through ITxPT records.
--	---

Power Supply	Voltage range: 24VDC (12~31.2VDC) Connection method: M12(Male), 4-Pin A-Coded Connection protection: anti-reverse connection
---------------------	--

Power Consumption	No-load at normal temperature: 10.12W@24VDC Full-load at normal temperature: 12.25W@24VDC
--------------------------	--

Working Environment	Operating temperature: -40~75°C Storage temperature: -40~85°C Relative humidity: 5%~95% (no condensation)
----------------------------	---

Mechanical Structure	Housing: IP67 protection, metal Installation: wall mounting Dimension (W x H x D): 230.1mm×80.5mm×159.97mm Weight: 2.558kg
-----------------------------	---

Industrial Standard	IEC 61000-4-2 (ESD, electronic static discharge), Level 4 <ul style="list-style-type: none"> Air discharge: ± 15kV Contact discharge: ±8kV IEC 61000-4-4 (EFT, electrical fast transient), Level 4 <ul style="list-style-type: none"> Power supply: ±4kV Ethernet interface: ±2kV Relay: ±4kV IEC 61000-4-5 (Surge), Level 4 <ul style="list-style-type: none"> Power supply: common mode ±4kV, differential mode ±2kV Relay: common mode ±4kV, differential mode ±2kV Ethernet interface: common mode±4kV Shock: IEC 61373 Free fall: IEC 60068-2-31 Vibration: IEC 61373
----------------------------	---

Authentication	CE, FCC, RoHS, ITxPT
-----------------------	----------------------

Warranty	5 years
-----------------	---------

Ordering Information

Model	100M M12	Gigabit M12 (With one pair of Bypass)	Power Supply
TNS5800B-16T4GT-P24	16	4	12~31.2VDC power input



Address: 3/B, Zone 1, Baiwangxin High Technology Industrial Park, Song Bai Road, Nanshan District, Shenzhen, 518108, China

TEL.: +86-755-26702668 ext 835

FAX: +86-755-26703485

E-mail: ics@3onedata.com

Website: www.3onedata.com

◀ [Please scan our QR code for more details](#)

*Product pictures and technical data in this datasheet are only for reference. Updates are subject to change without prior notice. The final interpretation right is reserved by 3onedata.