



# RS-232/RS-485/RS-422 UT-207 Photoelectric Isolation Interface Converter User Manual

## I. Summary

Compatible with the Recommended Standards of RS-232C , RS-422 and RS-485 , UT-207 photoelectric isolation interface converter can convert the single-ended RS-232 signal into balance differenced RS-422 or RS-485 signal. The built-in photoelectric isolator can provide an isolation voltage of as high as 250Vrms. Also , there is a rapid transient voltage suppression protector for protection of RS-422/RS-485 interface with advanced TVS(TRANSIENT VOLTAGE SUPPRESSOR) technology adopted. Under normal conditions , the TVS tube is in the state of high resistance. However , when both ends of the TVS tube are hit by a transient high energy , the impedance at both ends can be depressed by the TVS at a very high speed , and after absorbing a high current , the voltage between the two ends is suppressed and kept at a pre-set value , therefore no damage is caused to the electrical components behind by the transient high voltage impact. The protector can effectively restrain lightning or ESD (electro static discharge) with a protection voltage of 600W on each line for lightning surge and surge voltage or transient over voltage possibly caused up by various reasons , and at the same time , a high-speed transmission of RS-422/RS-485 interface is ensured by the tiny capacitance between the poles. Through a DB9 female connector RS-232 interface is connected to other interfaces compatible with RS-232C standard , and for RS-422 and RS-485 interfaces a DB9 male connector is to be used for connection. The unique I/O circuit of the internal zero delay auto transceiver contained in the converter controls the data stream direction automatically without any handshaking signal (for example RTS , DTR etc). The converter is plug-and-play without any jumper settings needed for mode shift between full duplex (RS-422) and half duplex (RS-485).

The converter is applicable for all the existing communication software and interface hardware without any software modifications for the previous working mechanism based on RS-232.

A reliable and stable point-to-point and point-to-multipoint communication can be ensured by UT-207 photoelectric isolation interface converter. For point-to-multipoint communication , as many as 32 interface facilities of RS-422 or RS-485 standard can be connected to each converter , and a high data transmission rate of 300-115.2KBPS can be achieved. Power indicator light and data traffic indicator light are also available with the converter for malfunction indication. Two conversion communication modes including RS-232 to RS-422 and RS-232 to RS-485 are supported.

## II. Performance parameters

1. Interface characteristic: compatible with the standards of RS-232C and RS485/RS-422 issued by EIA/TIA.
2. Electric interface: DB25 female connector for RS-232 interface input end , 4PIN/RJ11 male connector for RS-422/RS-485 interface output end.
3. Protection grade: +/-15KV ESD protection for RS-232 interface, and 600W surge protection each line for RS-422 and RS-485 interfaces.
4. Isolation degree: isolation voltage 2500Vrms 500DC non-stop.
5. Operation mode: asynchronous half duplex or asynchronous full duplex.
6. Signal indication: 3 pilot lamps for Power (PWR), Send (TXD) and Receive (RXD).
7. Transmission media: twisted pair cable or shielded cable.
8. Transmission rate: 115.2K BPS to 300M, 38.4K BPS to 2.4KM and 9,600 BPS to 5KM.
9. Dimensions: 113mm\*55mm\*25mm.
10. Working circumstance: -25 to 70 , relative humidity 5% -95%.
11. Transmission distance: 0-1,200meters (115,200bps-9,600bps).

## III. Connector and signal

RS-232C bay-line distribution

DB 9 Female (PIN)	RS-232C Interface signal
1	Earth protection
2	Receive data SIN(RXD)
3	Send data SOUT (TXD)
4	Data terminal ready DTR
5	Ground signal GND
6	Data setting ready DSR
7	Request send RTS
8	Clear send CTS
9	Ring indication RI

RS-485/RS-422 output signal and connector end bay-line distribution

RJ-11 and connection(PIN)	Output signal	RS-422 full-duplex connection	RS-485 half-duplex connection
1	T/R+	Send(A+)	RS-485 (A+)
2	T/R-	Send(B-)	RS-485 (B-)
3	RXD-	Receive(B-)	N/A
4	RXD+	Receive(A+)	N/A

RJ-11 bay-line distribution



## IV. Hardware installment and application

Read the user manual carefully before installing the UT-207 photoelectric isolation interface converter. Connect the attached communication cable to RS-232 interface, and insert the power supply converter to power socket. The product adopts the DB-9/DB-9 general used connector for input and output interface without jumper setting for RS-485 or RS-422 automatic communication mode. Either twisted pair cable or shielded cable is applicable for easy installation or un-installation. T/R+T/R-represents sending and receiving the A+/B-, RXD+/RXD- represents receiving the A+/B-, VCC represents power input or output, GND represents public underground line. Point-to-point and point-to-multipoint

Half duplex communication use the two lines of T/R+ and T/R- , point-to-point and point-to-multipoint full duplex communication use the four lines of T/R+ , T/R- , RXD+ and RXD-.

UT-207 interface converter supports the following 4 communication modes:

1. Point-to-point 4-line full duplex
2. Point-to-multipoint 4-line full duplex
3. Point-to-point 2-line half duplex
4. Point-to-multipoint 2-line half duplex

In order to prevent the signal reflection or interference when converter is used in full-duplex or half-duplex mode, a proper matching resistance should be connected at the terminal of the line (120Ω 1/4W).

### V. Communication connection chart

Conversion from RS-232 to RS-422

1. RS-422 point-to-point 4-line full duplex communication

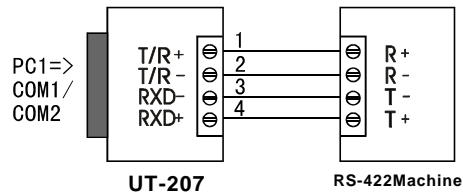

2. RS-485 point-to-multipoint /2-line half duplex

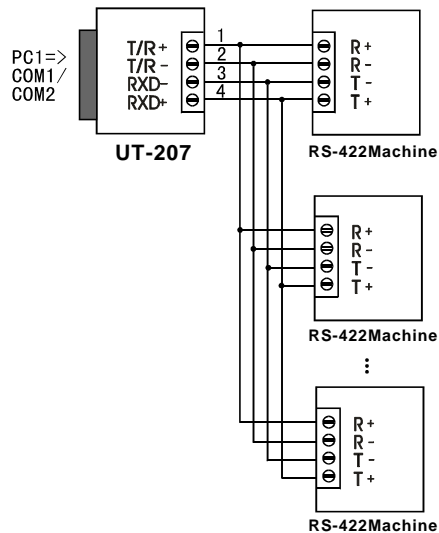

3. Half-duplex communication connections between UT-207 interfaces

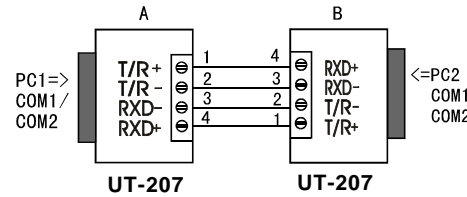

Conversion from RS-232 to RS-485

1. RS-485 point-to-point /2-line half duplex

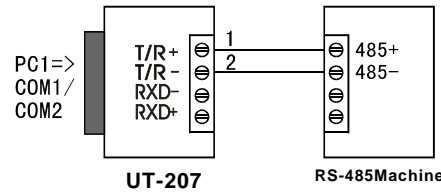

2. RS-485 point-to-multipoint /2-line half duplex

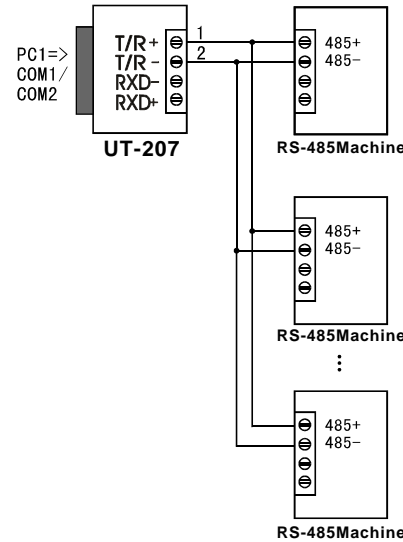

3. Half-duplex communication connections between UT-207 interfaces

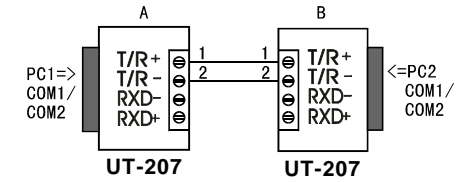

### VI. Problems and resolutions

1. Data communication failure

- A. Make sure RS-232 interface connection is correct.
- B. Make sure RS-485/RS-422 output interface connection is correct.
- C. Make sure power supply is OK.
- D. Make sure the wire terminal connection is OK.
- E. Make sure the pilot lamp flashes when receiving.
- F. Make sure the pilot lamp flashes when sending.

2. Data missing or incorrect

- A. Check to see whether if the data rate and format at both ends of the communication equipment are consistent.