

IN485SAM001R000 User Manual

Samsung NASA Systems to BACnet MS/TP and Modbus RTU

USER MANUAL
Version 1.0.0
Publication date 2026-03-11

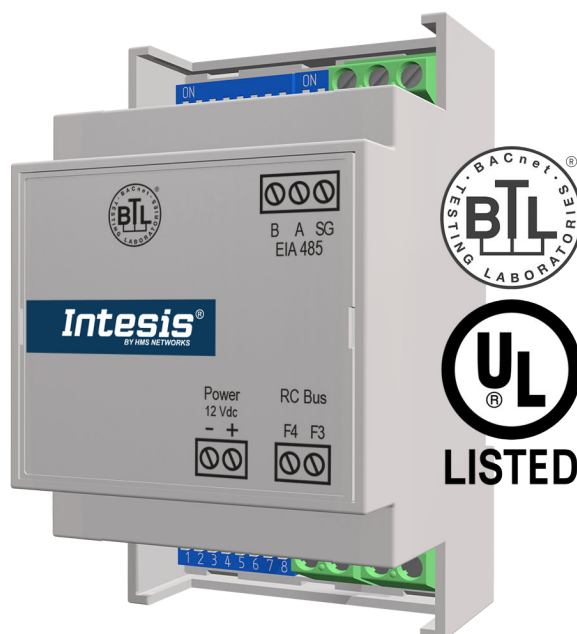

Copyright © 2026 Intesis

Disclaimer

The information in this document is for informational purposes only. Please inform HMS Networks of any inaccuracies or omissions found in this document. HMS Networks disclaims any responsibility or liability for any errors that may appear in this document.

HMS Networks reserves the right to modify its products in line with its policy of continuous product development. The information in this document shall therefore not be construed as a commitment on the part of HMS Networks and is subject to change without notice. HMS Networks makes no commitment to update or keep current the information in this document.

The data, examples and illustrations found in this document are included for illustrative purposes and are only intended to help improve understanding of the functionality and handling of the product. In view of the wide range of possible applications of the product, and because of the many variables and requirements associated with any particular implementation, HMS Networks cannot assume responsibility or liability for actual use based on the data, examples or illustrations included in this document nor for any damages incurred during installation of the product. Those responsible for the use of the product must acquire sufficient knowledge in order to ensure that the product is used correctly in their specific application and that the application meets all performance and safety requirements including any applicable laws, regulations, codes and standards. Further, HMS Networks will under no circumstances assume liability or responsibility for any problems that may arise as a result from the use of undocumented features or functional side effects found outside the documented scope of the product. The effects caused by any direct or indirect use of such aspects of the product are undefined and may include e.g. compatibility issues and stability issues.

Table of Contents

1. Description and Order Codes	1
2. General Information	2
2.1. Intended Use of the User Manual	2
2.2. General Safety Information	2
2.3. Admonition Messages and Symbols	3
3. Quick Start Guide	4
4. Overview	5
4.1. Inside the Package	6
4.2. Main Features	6
4.3. Gateway Capacity	6
4.4. General Functionality	6
5. Hardware	8
5.1. DIP Switches	8
5.2. Mounting	10
5.3. Connection Procedure	11
5.4. Connection to an External Power Supply	12
5.5. LED Indicators	13
5.6. Technical Specifications	14
5.7. Dimensions	14
6. Setting the Indoor Unit's Reference Temperature via a BACnet/Modbus Thermistor	15
7. Restore the Factory Settings	16
8. BACnet Specifications	17
8.1. Supported Object Types	17
8.2. BACnet Objects	17
9. Modbus Specifications	21
9.1. Implemented Modbus Functions	21
9.1.1. Modbus Physical Layer	21
9.2. Modbus Registers	21
9.3. Characterization Bitfields	26
10. Dual Set Point (DSP) Function	28
11. Error Codes	29

1. Description and Order Codes

BACnet MS/TP and Modbus RTU gateway for Samsung NASA HVAC systems.

Compatible with NASA HVAC systems commercialized by Samsung.

Use the compatibility tool to get a complete list of compatible units: <https://compatibility.intesis.com/>

ORDER CODE	LEGACY ORDER CODE
IN485SAM001R000	INBACSAM001R100 INMBSSAM001R100

2. General Information

2.1. Intended Use of the User Manual

This manual contains the main features of this Intesis gateway and the instructions for its appropriate installation, configuration, and operation.

Any person who installs, configures, or operates this gateway or any associated equipment should be aware of this manual's contents.

Keep this manual for future reference during the installation, configuration, and operation.

2.2. General Safety Information



IMPORTANT

Follow these instructions carefully. Improper work may seriously harm your health and damage the gateway and/or any other equipment connected to it.

Only technical personnel, following these instructions and the country legislation for installing electrical equipment, can install and manipulate this gateway.

Disconnect all systems from power before manipulating and connecting them to the gateway.

Install this gateway indoors, in a restricted access location, avoiding exposure to direct solar radiation, water, high relative humidity, or dust.

Preferably, mount this gateway on a DIN rail inside a grounded metallic cabinet, following the instructions in this manual.

If mounting on a wall, firmly fix this gateway on a non-vibrating surface, following the instructions in this manual.

Connect this gateway only to networks without routing to the outside plant.

All communication ports are considered for indoor use and must only be connected to SELV circuits.

If you connect the gateway to a power supply, use a SELV-rated NEC class 2 or limited power source (LPS) power supply.

Respect the expected polarity of power and communication cables when connecting them to the gateway.

Take the necessary antistatic precautions before manipulating the gateway to avoid electrostatic discharges.

Safety instructions in other languages can be found [here](#).

2.3. Admonition Messages and Symbols

**CAUTION**

Instruction that must be followed to avoid a potentially hazardous situation that, if not avoided, could result in minor or moderate injury.

**IMPORTANT**

Instruction that must be followed to avoid a risk of reduced functionality and/or damage to the equipment or to avoid a network security risk.

**NOTE**

Additional information which may facilitate installation and/or operation.

**TIP**

Helpful advice and suggestions.

**NOTICE**

Remarkable Information.

3. Quick Start Guide

1. Configure the gateway using the built-in DIP switches. See details in [DIP Switches \(page 8\)](#).
The gateway is delivered with the following default settings:

Default setting	DIP switch-Position: SETTING
BMS: BACnet MS/TP	1-5: OFF
Baud rate: Auto	1-6 .. 8: OFF
BACnet address: 0	2-1 .. 7: OFF
Temperature: Celsius	2-8: OFF
Termination resistor: Disabled	3-1: OFF
Bus polarization: Disabled	3-2 .. 3: OFF

2. Mount the gateway in the desired installation site. See details in [Mounting \(page 10\)](#).



NOTE

DIN rail mounting inside a grounded cabinet or metal enclosure is recommended.

3. Before wiring the gateway, disconnect all systems from power.
4. Use the **EIA-485** port to connect the gateway to the BACnet or Modbus system. See details in [Connection Procedure \(page 11\)](#).



IMPORTANT

- Use a shielded cable.
- Observe polarity: **B**: Negative, **A**: Positive, **SG**: Signal ground.
- For noise protection, use the shield as a drain wire by connecting it to the SG terminal at one end only.

5. Use the **RC Bus** port to connect the gateway to the Samsung F3F4 bus. See details in [Connection Procedure \(page 11\)](#).
6. If needed, use the **Power** port to connect the gateway to a power supply. See details in [Connection to an External Power Supply \(page 12\)](#).



IMPORTANT

- A power supply may be needed if the gateway shares the RC bus with other Samsung remote controllers.
- Use a SELV-rated NEC class 2 or limited power source (LPS) power supply.
- Apply the correct voltage and power: 12 VDC, 105 mA.
- Observe polarity.

7. Once connected to the gateway, reconnect all systems to power.
8. Check the communication performance of the systems and the gateway through the LED indicators. See details in [LED Indicators \(page 13\)](#).

4. Overview



NOTE

You can set the IN485SAM001R000 for BACnet MS/TP or Modbus RTU using the SW1-5 (DIP switch 1, position 5). See [DIP Switches \(page 8\)](#).

Figure 1. Integration of a Samsung NASA indoor unit into a BACnet MS/TP control system using the IN485SAM001R000 gateway

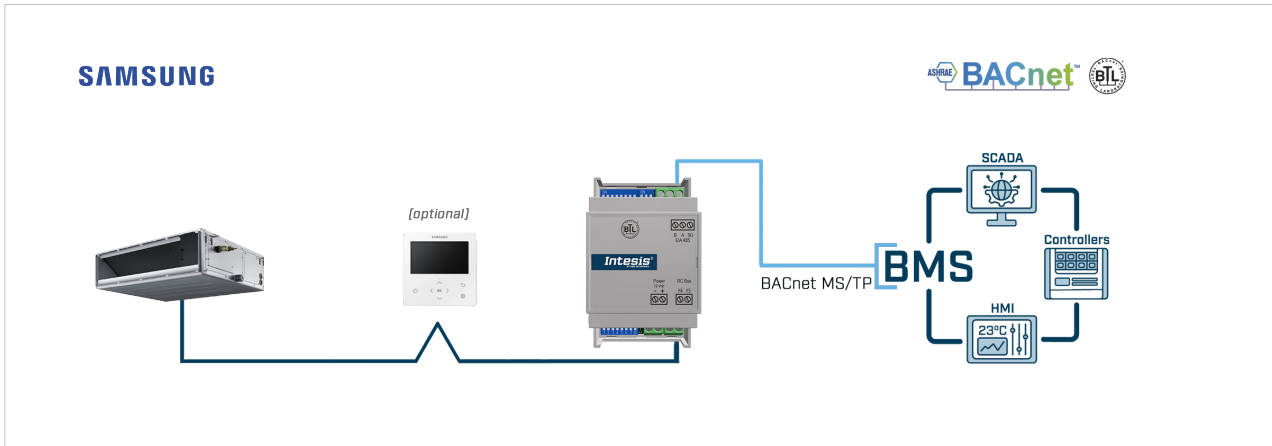
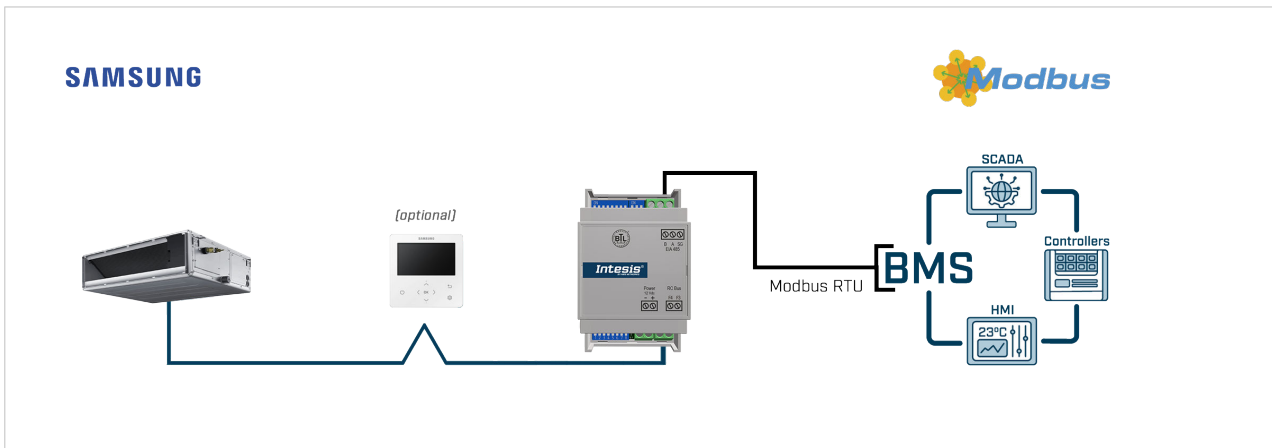

Figure 2. Integration of a Samsung NASA indoor unit into a Modbus RTU control system using the IN485SAM001R000 gateway



NOTE

This document assumes the user is familiar with BACnet, Modbus, and Samsung technologies, including their associated technical terminology.

4.1. Inside the Package

Items included:

- Intesis IN485SAM001R000 gateway
- Installation Guide

4.2. Main Features

- BTL certified.
- UL listed.
- Configurable for BACnet MS/TP and Modbus RTU.
- Configuration with DIP switches.
- Hybrid control of the indoor unit: local control through the wired remote controller (if present) and centralized control via the BMS simultaneously.
- Reduced dimensions (HxWxD): 93 x 53 x 58 mm / 3.7 x 2.1 x 2.3".
- Dual Set Point (DSP) function supported.
- AirClean and WindFree functions supported.
- > 40 communication signals implemented.
- Dedicated signals for maintenance and error monitoring.
- Three-year warranty.

4.3. Gateway Capacity

This Intesis gateway is intended for 1:1 control, i.e., it is designed to integrate a single indoor unit. However, it is also suitable for grouped control, as explained in the note below.



GROUPED CONTROL

You can connect several indoor units to the gateway, but they will operate as one. This means you cannot send different commands to different units.

Refer to the HVAC system's technical documentation to determine whether grouped control is allowed and to review the details of this feature.

4.4. General Functionality

With this Intesis gateway, you can easily integrate Samsung NASA indoor units into a control system based on BACnet MS/TP or Modbus RTU. On one side, the gateway connects to the control system through the EIA-485 connector, operating as a server device within the installation. On the other side, it connects to the NASA F3/F4 bus to access the Samsung unit's signals.

The gateway allows bidirectional communication between the control system and the HVAC system. It continuously polls the Samsung indoor unit, stores the current signal status in its memory, and serves this data to the control system when requested. The gateway also sends the commands received from the control system to the unit.

The gateway allows hybrid control of the indoor unit: local control through the wired remote controller (if present) and centralized control via the BMS simultaneously.

5. Hardware

5.1. DIP Switches

The gateway features three DIP switches: SW1 (8 positions) at the bottom and SW2 (8 positions) and SW3 (3 positions) at the top.

All configuration parameters of the gateway are set exclusively using its DIP switches, as detailed in the following tables. No software interface or external configuration tool is required.



IMPORTANT

Ensure the gateway is powered off before adjusting the DIP switches to avoid configuration errors or hardware damage.

The DIP switches configuration will only take effect after rebooting the gateway.

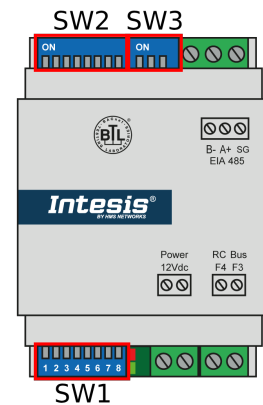

Table 1. **SW1** (P5): Control system selection; (P6 to P8): Baud rate

Position				Description	
5	6	7	8	BACnet	Modbus
OFF	X	X	X	Gateway set for BACnet MS/TP (default)	
ON	X	X	X	Gateway set for Modbus RTU	
X	OFF	OFF	OFF	Autobaudrate (default)	2400 bps (default)
X	ON	OFF	OFF	9600 bps	4800 bps
X	OFF	ON	OFF	19200 bps	9600 bps
X	ON	ON	OFF	38400 bps	19200 bps
X	OFF	OFF	ON	57600 bps	38400 bps
X	ON	OFF	ON	76800 bps	57600 bps
X	OFF	ON	ON	115200 bps	76800 bps
X	ON	ON	ON	Autobaudrate	115200 bps



NOTICE

SW1 positions 1 to 4 are not used.



BACNET MS/TP ONLY:

When **Autobaudrate** is selected, the gateway scans the network to find other BACnet MS/TP devices and match their baud rate. Once detected, the baud rate will only be modified after a reset/reboot of the gateway.

Table 2. **SW2 (BACnet MS/TP)** (P1 to P7): BACnet MS/TP MAC address; (P8): Temperature unit (°C/°F)

Position								BACnet address	Description
1	2	3	4	5	6	7	8		
OFF	OFF	OFF	OFF	OFF	OFF	OFF	X	0	-
ON	OFF	OFF	OFF	OFF	OFF	OFF	X	1	-
OFF	ON	OFF	OFF	OFF	OFF	OFF	X	2	-
ON	ON	OFF	OFF	OFF	OFF	OFF	X	3	-
...								...	-
ON	OFF	ON	ON	ON	ON	ON	X	125	-
OFF	ON	ON	ON	ON	ON	ON	X	126	-
ON	ON	ON	ON	ON	ON	ON	X	127	-
X	X	X	X	X	X	X	OFF	-	Temp. in °C (default)
X	X	X	X	X	X	X	ON	-	Temp. in °F

Table 3. **SW2 (Modbus RTU)** (P1 to P6): Modbus server address; (P7): Degree decimals setting; (P8): Temperature unit (°C/°F)

Position								Modbus address	Description
1	2	3	4	5	6	7	8		
ON	OFF	OFF	OFF	OFF	OFF	X	X	1	-
OFF	ON	OFF	OFF	OFF	OFF	X	X	2	-
ON	ON	OFF	OFF	OFF	OFF	X	X	3	-
...								...	-
ON	OFF	ON	ON	ON	ON	X	X	61	-
OFF	ON	ON	ON	ON	ON	X	X	62	-
ON	ON	ON	ON	ON	ON	X	X	63	-
X	X	X	X	X	X	OFF	X	-	Temp. in degrees x1 (default)
X	X	X	X	X	X	ON	X	-	Temp. in degrees x10. Example: 19.2°=192
X	X	X	X	X	X	X	OFF	-	Temp. in °C (default)
X	X	X	X	X	X	X	ON	-	Temp. in °F

**TIP**

To determine the position of each switch for addressing, convert the decimal value of the address to binary. A value of 0 indicates the switch is set to OFF, while a value of 1 indicates it is set to ON. Keep in mind that P1 represents the least significant bit (LSB).

Example to set the address 34:

1. Convert the value to binary: 100010.
2. Read the binary value from right (MSB) to left (LSB).
3. Set each switch accordingly: P1 = OFF, P2 = ON, P3 = OFF, P4 = OFF, P5 = OFF, P6 = ON

Table 4. **SW3** (P1 to P3): BACnet/Modbus polarization and termination resistor

Position			Description
1	2	3	
OFF	X	X	EIA-485 bus without termination resistor. The gateway is not at one end of the EIA-485 bus (default value)
ON	X	X	120 Ω termination resistor active. The gateway is at one end of the EIA-485 bus
X	OFF	OFF	No bus polarization (default value)
X	ON	ON	Bus polarization active

**IMPORTANT**

Observe the **ON** indicator on each DIP switch as a reference.

5.2. Mounting

Mount the gateway over a DIN rail or over a wall.

**IMPORTANT**

Before mounting, please ensure that the chosen installation place preserves the gateway from direct solar radiation, water, high relative humidity, or dust.

**IMPORTANT**

Leave enough clear space to wire the gateway easily and for the subsequent manipulation of elements such as connectors, DIP switches, etc.

**IMPORTANT**

Do not mount the gateway in air-handling units or conducts.

**NOTE**

DIN rail mounting inside a grounded metallic cabinet is recommended.

DIN rail mounting

1. Fit the gateway's top-side clip in the upper edge of the DIN rail.
2. Press the low side of the gateway gently to lock it in the DIN rail.
3. Make sure the gateway is firmly fixed.

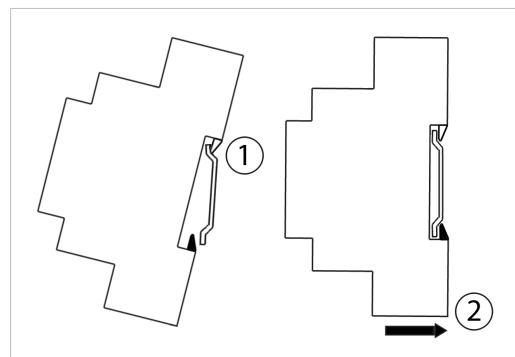
**NOTE**

For some DIN rails, to complete step 2, you may need a small screwdriver or similar to pull the bottom clip down.

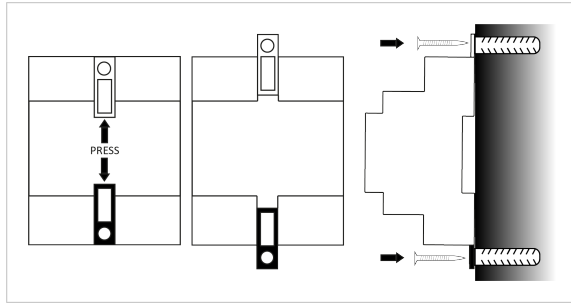

Wall mounting

1. Press the rear panel clips outwards until you hear a *click*.
2. Use the clip holes to screw the gateway to the wall.
3. Make sure the gateway is firmly fixed.

5.3. Connection Procedure

CAUTION ⚠️ Disconnect all systems from power before connecting them to the gateway.

IMPORTANT ❗ Keep communication cables as far away as possible from power and ground cables. Never bundle them together.

NOTE 📝 Mount the gateway in the desired place before wiring it.

TIP 💡 Wire strip length: 0.32" (8 mm).

1. **Connection to the BACnet MS/TP or Modbus RTU control system:** Connect the gateway's **EIA-485** port to the BACnet MS/TP or Modbus RTU bus.
2. **Connection to the power supply (optional):** See the next section [Connection to an External Power Supply \(page 12\)](#).
3. **Connection to the Samsung system:** Connect the gateway's **RC Bus** port at any point of the Samsung remote controller (RC) F3F4 bus.

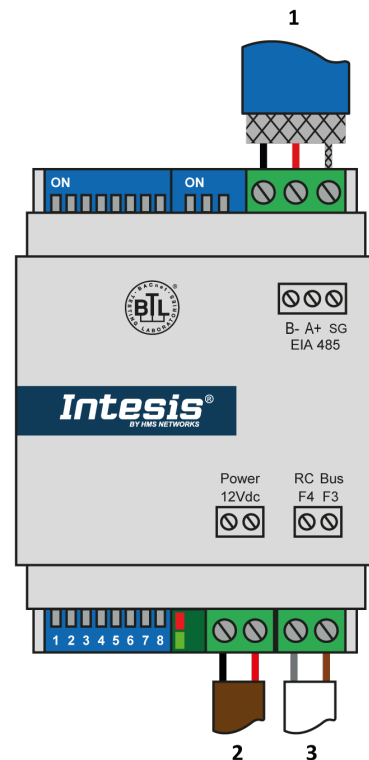

1. BACnet MS/TP or Modbus RTU EIA-485 bus
 2. Power supply
 3. Samsung F3 F4 bus

EIA-485 BUS WIRING ❗

- Use a shielded cable.
- Observe polarity: **B-**: negative, **A+**: positive, **SG**: Signal ground.
- For noise protection, use the shield as a drain wire by connecting it to the SG terminal at one end only.
- The EIA-485 bus doesn't allow loop or star topologies.
- The maximum length for the EIA-485 bus is 1200 meters (4000 feet).



EIA-485 BUS TERMINATION AND FAIL-SAFE BIASING

The EIA-485 bus requires a 120 Ω termination resistor at each end to avoid signal reflections.

When all transmitters are in high impedance (three-state), a fail-safe biasing mechanism is needed to maintain a valid voltage level and avoid false fail status detections.

The IN485SAM001R000 gateway features a 120 Ω built-in termination resistor that can be connected to the EIA-485 bus by using SW3-1 (DIP switch 3, position 1).

Some BACnet MS/TP / Modbus RTU EIA-485 master devices may also include internal termination and/or fail-safe biasing. Always check the Master device’s documentation.

If the gateway is installed at one end of the bus and termination is enabled, do not add another resistor at that end.

To know more, refer to the document [Polarity Issues in RS485 Networks](#).

5.4. Connection to an External Power Supply



IMPORTANT

In most cases, the gateway is powered through the remote controller bus itself, and there is no need to connect an external power supply. However, depending on the number and type of remote controllers installed, the bus could not supply the needed power.



TIP

Some signs indicating there is not enough power in the bus may include, for example, a malfunction of the remote controllers' display or in its performance.

If that's the case, connect a SELV-rated NEC class 2 or Limited Power Source (LPS) power supply to the gateway's **Power** connector.



IMPORTANT

- Apply the correct voltage and power: 12 VDC, 105mA.
- Observe polarity.

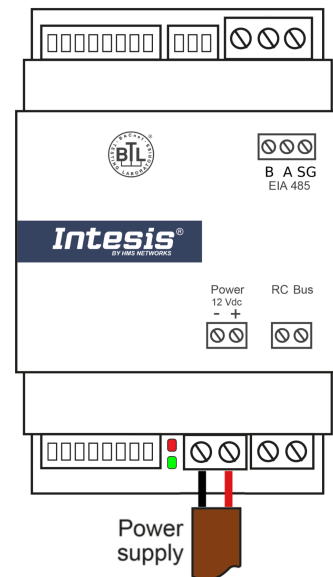

5.5. LED Indicators

The gateway features two LEDs located on the lower side, between the SW1 DIP switch and the **Power** connector.



TIP

When powering on the gateway, both LEDs blink once and then turn off.

After that, LEDs will behave as described in the table below:

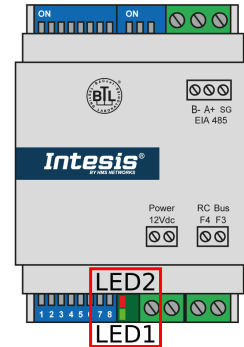

LED	Status	Description
When the gateway is set for BACnet MS/TP		
L1 Green	ON	EIA-485 bus link performed
	Flickering	Activity on the EIA-485 bus
	OFF	EIA-485 bus link not performed
L2 Red	ON	AC unit-gateway communication error
	Blinking	AC unit error
	Flashing	AC unit-gateway communication OK
When the gateway is set for Modbus RTU		
L1 Green	Blinking	Any error in the AC unit
	Flashing	Normal operation
L1 Green + L2 Red	Pulse	Gateway startup



LED PATTERNS

- **ON:** 100% on
- **Flickering:** irregular cycle (90% on - 10% off approx)
- **Blinking:** 50% on - 50% off
- **Flashing:** 10% on - 90% off
- **Pulse:** 5 seconds on - then off
- **OFF:** 100% off

5.6. Technical Specifications

Housing	Plastic, type PC (UL 94 V-0) Net dimensions (HxWxD): 93 x 53 x 58 mm / 3.7 x 2.1 x 2.3" Color: Light grey. RAL 7035 Protection: IP20
Net weight	85 g (3 oz)
Terminal wiring	Wire cross-section/gauge per terminal: One core: 0.2..2.5 mm ² (24..11 AWG) Two cores: 0.2..1.5mm ² (24..15 AWG) Three cores: Not permitted Use solid or stranded wires (twisted or with ferrules)
External power supply (optional)	SELV-rated NEC class 2 or limited power source (LPS) 12 VDC; 105 mA
Mounting	DIN rail or wall
EIA-485 port	1 x pluggable terminal block (3 poles: B-, A+, and SG)
BACnet MS/TP - Modbus RTU	Use a shielded cable
AC unit port	1 x RC bus pluggable terminal block (2 poles: F3 and F4)
LED indicators	2 x Communication status
DIP switches	SW1: Control system selection and baud rate configuration SW2: BACnet/Modbus address and temperature settings SW3: Bus polarization and termination
Operational temperature	0 to +70°C / 32 to 158°F
Storage temperature	-20 to 85°C / -4 to 185°F
Operational and storage humidity	5% to 95% RH non-condensing
Isolation between comm. ports	1000 VDC

5.7. Dimensions

Net dimensions (HxWxD):
Millimeters: 93 x 53 x 58 mm
Inches: 3.66 x 2.08 x 2.28"

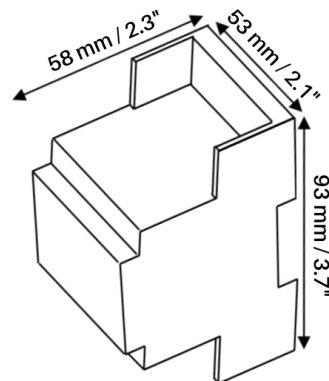

IMPORTANT

Leave enough clear space to wire the gateway easily and for the subsequent manipulation of elements such as connectors, DIP switches, etc.

6. Setting the Indoor Unit's Reference Temperature via a BACnet/Modbus Thermistor

You can use a thermistor connected to the BACnet/Modbus system to overwrite the Samsung indoor unit's reference temperature through the gateway. Consider the following:



IMPORTANT

If a Samsung remote controller is present on the F3F4 bus (optional), it must be set as a sub (follower) controller.



NOTICE

The IN485SAM001R000 gateway operates as an independent device on the bus. It does not assume either role, and no configuration is required to set it as a sub (follower) or a main (header) controller.

Write the temperature provided by the BACnet/Modbus thermistor using the dedicated BACnet object/Modbus register:

- BACnet: **RoomTemperature_command** object.
- Modbus: **Input sensor temperature** register (Modbus address **22**).



IMPORTANT

Only write a valid value in this object/register when using this feature; that is, only when a thermistor is connected to the BMS and allowed to overwrite the reference temperature of the Samsung indoor unit. In all other cases, make sure the **RoomTemperature_command** BACnet object / **Input sensor temperature** Modbus register is set to **0x8000**.



TIP

If you have been using this feature and now want to stop, write the value **0x8000** to the **RoomTemperature_command** BACnet object / **Input sensor temperature** Modbus register.

7. Restore the Factory Settings

To restore the gateway to its factory settings, proceed as follows:

1. Set all switches from DIP switches SW1 and SW2 to **ON**.
2. Reboot the gateway:
 - a. Power it OFF.
 - b. Power it ON.



NOTE

To power the gateway OFF, disconnect it from the AC unit and from the power supply, if there is one. To power the gateway ON, reestablish those connections.

3. After the reboot, LEDs will blink with the SOS Morse sequence:
 - a. Three short blinks
 - b. Three longer blinks
 - c. Three short blinks
4. Set all switches from DIP switches SW1 and SW2 to **OFF** within 30 seconds.



IMPORTANT

If you take longer than 30 seconds, all LEDs will turn off, meaning that the procedure has failed. To retry it, go to step 1 and begin the procedure again.

After this procedure, the LED will flash red, meaning that the gateway has been restored to the factory settings.

8. BACnet Specifications

8.1. Supported Object Types

Object type	ID
Analog-Input	0
Analog-Output	1
Analog-Value	2
Binary-Input	3
Binary-Output	4
Binary-Value	5
Device	8
Multistate-Input	13
Multistate-Output	14

8.2. BACnet Objects



NOTICE

Temperature objects can be set to °C or °F using SW2-8 (DIP switch SW2, position 8). See [DIP Switches \(page 8\)](#).

Name	Possible values	Type	Instance
IN485SAM001R000 ¹	Read the information below.	8-Device	246000
<p>¹ This object identifies the gateway in the BACnet system, either automatically or manually:</p> <ul style="list-style-type: none"> Automatic addressing (default): This mode uses a base address of 246000 + the MAC address number set with the DIP switch SW2. See DIP Switches (page 8). Manual addressing: The gateway switches to this mode when the Object_Identifier property of this object is overwritten from the BACnet side. If so, the DIP switch SW2 configuration will not be considered for the Device instance calculation until the gateway is reset to the factory settings. See Restore the Factory Settings (page 16). <p>The Object_Name and Description properties of this object can be written.</p>			
OnOff_status	1: Off 2: On	3-Binary Input	0
OnOff_command	1: Off 2: On	4-Binary Output	0
Mode_status ²	1: Heat 2: Cool 3: Fan 4: Dry 5: Auto	13-Multistate Input	0

Name	Possible values	Type	Instance
Mode_command ²	1: Heat 2: Cool 3: Fan 4: Dry 5: Auto	14-Multistate Output	0
 FAN MODE ISSUE ² When the indoor unit is in Fan mode, the remote controller hides the temperature setpoint but keeps the old value internally. If the BMS sends a new setpoint during Fan mode, the unit accepts it, but the remote does not update its display. When switching back to a temperature-controlled mode, the BMS shows the correct new setpoint, while the remote displays the old one, creating an apparent mismatch. However, the remote controller will update the value when the BMS sends a new one while in a temperature-controlled mode.			
SetPoint_status	°C, °F	0-Analog Input	0
SetPoint_command	°C, °F	1-Analog Output	0
UserSetPoint_status	°C, °F	0-Analog Input	17
FanSpeed_status	1: Auto 2: Fan speed 1 3: Fan speed 2 4: Fan speed 3 5: Fan speed 4	13-Multistate Input	1
FanSpeed_command	1: Auto 2: Fan speed 1 3: Fan speed 2 4: Fan speed 3 5: Fan speed 4	14-Multistate Output	1
AirDirectionUD_status ³	1: Auto/Stop 2: Swing	13-Multistate Input	2
AirDirectionUD_command ³	1: Auto/Stop 2: Swing	14-Multistate Output	2
³ For the Cassette 360 model, the up/down air flow is monitored and controlled through the objects 360_CST_AirFlow_Direction_status and 360_CST_AirFlow_Direction_command listed below.			
AirDirectionLR_status	1: Auto/Stop 2: Swing	13-Multistate Input	3
AirDirectionLR_command	1: Auto/Stop 2: Swing	14-Multistate Output	3
RoomTemperature_status ⁴	°C, °F	0-Analog Input	1
RoomTemperature_command ⁴	°C, °F	1-Analog Output	1

Name	Possible values	Type	Instance
<p>⁴ Use this object to write the ambient temperature reported by a thermistor connected to the BACnet system.</p>			
<p>! IMPORTANT To use the RoomTemperature_command object, some considerations must be taken into account as explained in Setting the Indoor Unit's Reference Temperature via a BACnet/Modbus Thermistor (page 15).</p>			
ErrorCode	See Error Codes (page 29)	0-Analog Input	2
ErrorCodeM	See Error Codes (page 29)	13-Multistate Input	4
ErrorActive	1: No error 2: Error	3-Binary Input	1
ErrorAddress	Address of the indoor unit reporting the error.	0-Analog Input	4
OnTimeCounter	Accumulated operating time of the indoor unit in hours.	2-Analog Value	0
FilterSign	1: No 2: Yes	3-Binary Input	6
FilterSignAddress	Address of the indoor unit reporting the filter sign.	0-Analog Input	18
FilterReset	1: Normal 2: Reset	4-Binary Output	4
LockRemoteControl	1: Unlocked 2: Locked	5-Binary Value	2
DIP_SW_S1_status ⁵	Read the information below.	0-Analog Input	9
DIP_SW_S2_status ⁵	Read the information below.	0-Analog Input	10
<p>⁵ These objects indicate the status of the DIP switch block SW1 and SW2 in decimal value. To get the status of each individual switch (position), just convert the decimal value to binary. The gateway reads these values only when booting up.</p>			
SerialNumber ⁶	Read the information below.	0-Analog Input	11
<p>⁶ It indicates the serial number of the gateway with the pattern 000EXXXXX, where:</p> <ul style="list-style-type: none"> • 000E is constant and not included in the Present_Value property. • XXXXX is the unique device serial number. This is the information provided by the Present_Value. 			
Number_of_IU_connected	Number of indoor units connected to the RC bus.	0-Analog Input	19

Name	Possible values	Type	Instance
IU_Address_status_reported ⁷	Read the information below.	0-Analog Input	20
⁷ Address of the indoor unit that reports the status in case there is more than one indoor unit connected to the RC bus.			
IU_Pos_status_reported ⁸	Read the information below.	2-Analog Value	7
⁸ All indoor units connected to the RC bus are listed in an internal array in ascending address order. This register indicates the position, within that array, of the indoor unit currently reporting the status.			
WindFree_mode_status ⁹	1: Off 2: On	3-Binary Input	16
WindFree_mode_command ⁹	1: Off 2: On	4-Binary Output	13
⁹ The WindFree feature can be enabled in the cool, fan, and dry modes.			
AirClean_mode_status	1: Off 2: On	3-Binary Input	17
AirClean_mode_command	1: Off 2: On	4-Binary Output	14
360_CST_AirFlow_Direction_status ¹⁰	1: Spot 2: Mid 3: Wide 4: Swing 5: Other	13-Multistate Input	12
360_CST_AirFlow_Direction_command ¹⁰	1: Spot 2: Mid 3: Wide 4: Swing 5: Other	14-Multistate Output	8
¹⁰ For the Cassette 360 model, these objects monitor and control the up/down air flow.			
DualSetpoint_active ¹¹	1: Dual setpoint not active 2: Dual setpoint active	5-Binary Value	5
DualSetpoint_Heat_Temperature_status ¹¹	°C, °F	0-Analog Input	21
DualSetpoint_Heat_Temperature_command ¹¹	°C, °F	1-Analog Output	3
DualSetpoint_Cool_Temperature_status ¹¹	°C, °F	0-Analog Input	22
DualSetpoint_Cool_Temperature_command ¹¹	°C, °F	1-Analog Output	4
¹¹ See Dual Set Point (DSP) Function (page 28) .			

9. Modbus Specifications

The following sections provide the gateway's specifications when it is set for Modbus RTU.

9.1. Implemented Modbus Functions

The IN485SAM001R000 gateway implements the following standard Modbus functions:

- 03: Read Holding Registers
- 04: Read Input Registers
- 06: Write Single Register
- 16: Write Multiple Registers*



IMPORTANT

* Although Function 16 is supported, the gateway only allows writing one register per request. Therefore, the Length field in Function 16 frames must always be set to 1.

9.1.1. Modbus Physical Layer

The IN485SAM001R000 gateway's Modbus RTU (server) interface features an 8-N-2 communication (8 data bits, no parity, and 2 stop bits) with several available baud rates: **2400 -default-**, 4800, 9600, 19200, 38400, 57600, 76800, and 115200 bps. It also supports 8-N-1 communication (8 data bits, no parity, and 1 stop bit).



TIP

The gateway will automatically detect the communication type (8-N-1 or 8-N-2) and set itself accordingly. No user action or manual settings are required.

9.2. Modbus Registers



All registers use the standard Modbus big-endian notation.



NOTICE

Temperature registers can be set to °C, °Cx10, °F, °Fx10 using SW2-7 .. 8 (DIP switch SW2, positions 7 and 8). See [DIP Switches \(page 8\)](#).

Register name	Possible values	Modbus address (base 0)	PLC address (base 1)	R/W
On/Off	0: Off 1: On	0	1	R/W
Operation mode ¹ See Characterization Bitfields (page 26) .	0: Auto 1: Heat 2: Dry 3: Fan 4: Cool	1	2	R/W
 FAN MODE ISSUE ¹ When the indoor unit is in Fan mode, the remote controller hides the temperature setpoint but keeps the old value internally. If the BMS sends a new setpoint during Fan mode, the unit accepts it, but the remote does not update its display. When switching back to a temperature-controlled mode, the BMS shows the correct new setpoint, while the remote displays the old one, creating an apparent mismatch. However, the remote controller will update the value when the BMS sends a new one while in a temperature-controlled mode.				
Fan speed See Characterization Bitfields (page 26) .	0: Auto 1 .. 4: Fan speed 1 .. 4	2	3	R/W
Vane U/D position ² See Characterization Bitfields (page 26) .	0: Auto/Stop 10: Swing	3	4	R/W
² For the Cassette 360 model, the up/down air flow is monitored and controlled through the register 360° air flow direction (Modbus address 139) listed below.				
Temperature (user) setpoint	Temperature requested from the Modbus BMS. °C, °Cx10, °F, °Fx10 0x8000 (-32768): Initialization value.	4	5	R/W
Indoor unit reference temperature	°C, °Cx10, °F, °Fx10 0x8000 (-32768): Initialization value.	5	6	R
Window contact protocol input	0x0000: Default value (all sensors say "Window closed"). Any of the 16-bit is set to 1: Its associated window contact is open.	6	7	R/W
Control objects disablement ³	0: Objects enabled 1: Objects disabled	7	8	R/W
³ It enables/disables the control of the AC unit through the BMS. If a value of 1 is written in this register, the AC unit can only be controlled through its remote controller, and any command sent from the BMS will have no effect.				

Register name	Possible values	Modbus address (base 0)	PLC address (base 1)	R/W
 TROUBLESHOOTING If for an unknown reason the gateway does not work, ensure this register is set to 0 .				
Remote control disablement ⁴	0: RC enabled 1: RC disabled	8	9	R/W
⁴ It enables/disables the control of the AC unit through its remote controller. If a value of 1 is written in this register, the AC unit can only be controlled through the BMS, and any command sent through any remote controller will have no effect.				
Operation time (hours)	Accumulated operating time of the AC unit in hours.	9	10	R/W
Alarm status	0: No Error present 1: Error present	10	11	R
Error code	See Error Codes (page 29) .	11	12	R
Open window timeout (minutes)	0 .. 30 min	13	14	R/W
Baudrate	1: 2400 bps 2: 4800 bps 3: 9600 bps 4: 19200 bps 5: 38500 bps 6: 57600 bps 7: 76800 bps 8: 115200 bps	14	15	R
Modbus slave address	1 .. 63	15	16	R
Maximum number of fan speeds	Configured number of fan speeds.	21	22	R
Input sensor temperature ⁵	°C, °Cx10, °F, °Fx10 0x8000 (-32768): Initialization value. No temperature is being provided from a thermistor connected to the Modbus BMS.	22	23	R/W
⁵ Use this register to write the ambient temperature reported by a thermistor connected to the Modbus system.				
 IMPORTANT To use the Input sensor temperature register, some considerations must be taken into account as explained in Setting the Indoor Unit's Reference Temperature via a BACnet/Modbus Thermistor (page 15) .				

Register name	Possible values	Modbus address (base 0)	PLC address (base 1)	R/W
AC real setpoint	Temperature setpoint sent to the indoor unit. °C, °Cx10, °F, °Fx10	23	24	R
Current AC maximum setpoint	°C, °Cx10, °F, °Fx10	24	25	R
Current AC minimum setpoint	°C, °Cx10, °F, °Fx10	25	26	R
Vane L/R position See Characterization Bitfields (page 26) .	0: Auto/Stop 10: Swing	26	27	R/W
Window contact functional status (feedback)	0: Not active 1: Active (A window is open)	31	32	R
Window contact On/Off disablement	0: Window contact is not disabling On/Off 1: Window contact is disabling On/Off at this moment	40	41	R
Filter reset	1: Reset	43	44	W
Filter status	0: Off 1: Lit	44	45	R
Switch value ⁶	Current value of DIP switches.	48	49	R
⁶ Once converted to binary, the reported value shows each switch OFF (0) or ON (1) position for both SW1 and SW2.				
Return path temperature	°C, °Cx10, °F, °Fx10 0x8000 (-32768): Initialization value.	66	67	R
Number of IU connected	Number of indoor units connected to the RC bus.	67	68	R
IU # status reported ⁷	Read the information below.	68	69	R/W
⁷ All indoor units connected to the RC bus are listed in an internal array in ascending address order. This register indicates the position, within that array, of the indoor unit currently reporting the status.				
IU address status reported ⁸	Read the information below.	69	70	R
⁸ Address of the indoor unit that reports the status in case there is more than one indoor unit connected in the RC bus.				
Error address	Address of the indoor unit reporting the error.	81	82	R
Filter signal address	Address of the indoor unit reporting the signal address.	86	87	R

Register name	Possible values	Modbus address (base 0)	PLC address (base 1)	R/W
FW version MSB	First two numbers of the firmware version. Example: For version 1.2.3.4, it will show 1.2 (in hexadecimal).	94	95	R
FW version LSB	Last two numbers of the firmware version. Example: For version 1.2.3.4, it will show 3.4 (in hexadecimal).	95	96	R
Reset	1: Reset	99	100	W
Window contact step	0: Contact weak (window closed) 1: Contact strong (no action executed) 2: Contact strong (action executed) 3: Contact strong (action executed)	130	131	R
WindFree ⁹	0: Off 1: On	137	138	R/W
⁹ The WindFree feature can be enabled in the cool, fan, and dry modes.				
AirClean	0: Off 1: On	138	139	R/W
360° air flow direction ¹⁰	0: Spot 1: Mid 2: Wide 3: Swing 4: Other	139	140	R/W
¹⁰ For the Cassette 360 model, this register monitors and controls the up/down air flow.				
Dual setpoint ¹¹	0: Off 1: On	140	141	R/W
Dual setpoint heat temperature ¹¹	°C, °Cx10, °F, °Fx10	141	142	R/W
Dual setpoint cool temperature ¹¹	°C, °Cx10, °F, °Fx10	142	143	R/W
¹¹ See Dual Set Point (DSP) Function (page 28) .				
Window contact reload last value	0: No 1: Yes	1000	1001	R/W

Register name	Possible values	Modbus address (base 0)	PLC address (base 1)	R/W
Window contact lock when open	0: No 1: Yes	1001	1002	R/W
Window timeout	0 .. 30 min	1002	1003	R/W
Machine mode	0: Normal 1: NA 2: Limited setpoint	1150	1151	RW
Machine minimum setpoint cool ¹²	°C / °F (default value 24°C / 75°F)	1153	1154	RW
Machine maximum setpoint cool ¹²	°C / °F (default value 28°C / 82°F)	1154	1155	RW
Machine minimum setpoint heat ¹²	°C / °F (default value 19°C / 66°F)	1155	1156	RW
Machine maximum setpoint heat ¹²	°C / °F (default value 23°C / 73°F)	1156	1157	RW
¹² Custom limits defined in these registers only apply if the register Machine mode (Modbus address 1150) is set to 2: Limited setpoint .				
Remote lock on non-volatile memory (RC lock after reset)	0: RC enabled after reset (Default) 1: The register Remote control disablement (Modbus address 8) keeps its value after a reset	1220	1221	RW

9.3. Characterization Bitfields

Table 5. Operation mode

Bit 15	Bit 04	Bit 03	Bit 02	Bit 01	Bit 00
1: Invalid	COOL	FAN	DRY	HEAT	AUTO
0: Valid	1: Enabled 0: Disabled				

Table 6. Fan speed

Bit 15	Bit 04	Bit 03	Bit 02	Bit 01	Bit 00
1: Invalid	FAN_4	FAN_3	FAN_2	FAN_1	AUTO
0: Valid	1: Enabled 0: Disabled				

Table 7. Vanes

Bit 15	Bit 03	Bit 02	Bit 01	Bit 00
1: Invalid	PULSE L/R	PULSE U/D	SPECIFIC L/R	SPECIFIC U/D
0: Valid	1: Enabled 0: Disabled			

Table 8. Vane U/D

Bit 15	Bit 10	Bit 00
1: Invalid	SWING ON	SWING OFF (AUTO)
0: Valid	1: Enabled 0: Disabled	

Table 9. Vane L/R

Bit 15	Bit 10	Bit 00
1: Invalid	SWING ON	SWING OFF (AUTO)
0: Valid	1: Enabled 0: Disabled	

10. Dual Set Point (DSP) Function

The DSP function allows you to specify separate setpoint temperatures for the heating and cooling modes.



NOTICE

When activating the DSP function, ensure the wired remote controller (RC) in the Samsung system is set to DSP mode. Otherwise, the wired RC will display the average of the DSP heat and DSP cool temperatures.



IMPORTANT

The gateway cannot detect if the DSP function is enabled in the Samsung system. The function must be enabled from the BMS as explained in the following procedures.

ACTIVATING THE DSP FUNCTION IN BACNET

1. Set the **DualSetpoint_active** object to **2**.
2. Write the desired temperature value for the heat mode in the **DualSetpoint_Heat_Temperature_command** object.
3. Write the desired temperature value for the cool mode in the **DualSetpoint_Cool_Temperature_command** object.

ACTIVATING THE DSP FUNCTION IN MODBUS

1. Set the register **Dual Setpoint (Modbus address 140)** to **1**.
2. Write the desired temperature value for the heat mode in the register **Dual setpoint heat temperature (Modbus address 141)**.
3. Write the desired temperature value for the cool mode in the register **Dual setpoint cool temperature (Modbus address 142)**.



NOTICE

To know more about the DSP function, refer to the documentation provided with the Samsung system.

11. Error Codes

GATEWAY ERROR CODES

Error code	Description
-4	The gateway is starting up.
-1	Communication error between the gateway and the Samsung system.
0	No active error.

SAMSUNG SYSTEM ERROR CODES



NOTICE

The following tables show a complete, official list of error codes for Samsung systems with no model-specific distinctions.



TIP

Refer to the documentation provided with the Samsung system for its specific error codes.



NOTE

If you detect a non-listed error code, please contact Samsung technical support.

E101 .. 120: Communication error - Indoor unit

Error code	Description
101	Indoor unit communication error, indoor unit cannot receive communication. (no communication response from outdoor unit)
102	Communication error between indoor and outdoor unit.
103	Communication error between indoor unit and fascia panel.
104	[GHP-R22] Communication error between "Indoor-Host" and "Indoor-Focus"
105	Communication error between the space sensor module and the indoor unit
106	Communication error between LCD and panel.
107	Communication error between LCD and outdoor unit.
108	Duplicate indoor addresses - overlapping of indoor unit addresses on a system.
111	Communication error between the Commkit and the Controller (be made by another company)
120	Indoor unit room (return air) temperature sensor 2 is open/short.

E121 .. 150: Sensor error - Indoor unit	
Error code	Description
121	Indoor unit room (return air) temperature sensor is open/short.
122	Indoor unit evaporator inlet (Eva_in) temperature sensor is open/short.
123	Indoor unit evaporator outlet (Eva_out) temperature sensor is open/short.
124	Indoor unit communication error.
125	Indoor unit evaporator mid (Eva_mid2) temperature sensor is open/short.
126	Indoor unit discharged air temperature sensor is open/short.
127	[GHP-R22] Indoor temperature (inhalation temperature) sensor separation error.
128	Indoor unit evaporator inlet (Eva_in) temperature sensor has separated from the pipe/coil. This can also occur due to poor/inaccurate temperature reading.
129	Indoor unit evaporator outlet (Eva_out) temperature sensor has separated from the pipe/coil. This can also occur due to poor/inaccurate temperature reading.
130	Indoor unit evaporator inlet and evaporator outlet (Eva_in, Eva_out) temperature sensor has separated from the pipe/coil.
131	Sensor_1 error of optional electric heater #1
132	Sensor_2 error of optional electric heater #2
133	Sensor_3 error of optional electric heater #3
134	Shutter sensor err.
135	Perfect fan sensor error
136	Bottom shutter sensor error (if the shutter model has two types, an error in the model at the bottom: Aurora)
137	VOC sensor open/short error.
138	GAS sensor open/short error.
139	CO ₂ sensor in ERV (Energy Recovery Ventilator) open/short error.
140	Indoor unit "Dust" sensor error.
141	CO ₂ sensor in IAQ (Indoor Air Quality) unit open/short error.
142	Indoor unit humidity sensor open/short error.
143	Space detection sensor error.
144	Indoor unit evaporator inlet #2 (Eva2_in) temperature sensor is open/short.
145	Indoor unit evaporator outlet #2 (Eva2_out) temperature sensor is open/short.
146	EEV (Electronic Expansion Valve) inlet sensor is open/short.
147	Indoor unit evaporator inlet #2 (Eva2_in) temperature sensor has separated from the coil/pipe.
148	Indoor unit evaporator outlet #2 (Eva2_out) temperature sensor has separated from the coil/pipe.
149	AHU Master indoor unit indoor sensor setup error.

E151 .. 200: ETC - Indoor unit	
Error code	Description
151	Indoor unit EEV (Electronic Expansion Valve) closing error - second detection.
152	Indoor unit EEV (Electronic Expansion Valve) opening error - second detection.
153	Indoor unit condensate float switch error - second detection
154	Indoor unit fan motor error.
155	Indoor fan motor #2 error.
156	Indoor unit EEV #2 (Electronic Expansion Valve) closing error - 2nd detection.
157	Indoor unit EEV #2 (Electronic Expansion Valve) opening error - 2nd detection.
158	Upper UDoor operation error
159	Lower UDoor operation error
160	Locking error of drain pump.
161	Mixed operation error (cooling and heating). Occurs when operating signals from wired, wireless and other controllers in multi-split and VRF heat pump systems call for heating and cooling at the same time.
162	Error in outdoor unit's EEPROM
163	Indoor unit remote controller option input is incorrect or missing. Outdoor unit EEPROM data error.
165	Discharge air temperature protection from electric heater error.
166	Fan motor does not operate when electric heat activates.
167	Error due to the wrong configuration of DIP switch for using additional controllers.
168	IAQ Safety S/W Open Error
169	AHU EEV (Electronic Expansion Valve) malfunction error.
170	Temperature display error - mismatched units of measure (Fahrenheit/Celsius) on same system. Occurs when wired controllers and indoor units (non-NASA) are configured for Fahrenheit and Celsius on the same system (F1/F2).
171	Evaporator "Mid" sensor error.
172	Inlet temperature sensor on AHU's evaporator has separated from the coil/pipe.
173	Outlet temperature sensor on AHU's evaporator has separated from the coil/pipe.
174	ERV Plus indoor unit return air (RA) temperature sensor is open/short.
175	Indoor unit internal outside temperature sensor short/open error
176	Indoor fan #3 error
177	Emergency signal from hydro unit.
178	Data flash hardware error
179	Integrated Proximity and Ambient Light Sensor
180	MCU cooling and heating solenoid valves are open at the same time - first detection
181	MCU cooling and heating solenoid valves are open at the same time - second detection
182	ERV (Energy Recovery Ventilator) indoor humidity sensor error
183	ERV (Energy Recovery Ventilator) outdoor humidity sensor error
184	Full Water Level Detection Error
185	Reversed connection between communication and power supply in indoor unit.
186	SPI (Virus doctor) feedback error

E151 .. 200: ETC - Indoor unit	
Error code	Description
187	K1 Filter Feedback error
188	K1 Filter2 Feedback error
189	Enthalpy Sensor Error (current range 4mA-20mA)
190	No temperature change at EEV inlet (Eva_in) temperature sensor on an evaporator during pipe check operation. Temperature change at EEV inlet (Eva_in) temperature sensor seen on other evaporator during pipe check operation.
191	No temperature change at EEV outlet (Eva_out) temperature sensor on an evaporator during pipe check operation. Temperature change at EEV outlet (Eva_out) temperature sensor seen on other evaporator during pipe check operation.
192	Indoor unit control box panel opening error (safety switch error)
193	Indoor unit Panel Zero-Crossing Error
194	Indoor unit Main Zero-Crossing Error
195	IAQ Safety S/W Open Error
196	PM10 SENSOR Error
197	PM2.5 SENSOR Error
198	Thermal fuse error (This error occurs when the terminal block has overheated.)
199	Pipe-check operation has not been completed.
200	Indoor unit fan motor #4 error.

E201 .. 209: Communication error - Outdoor unit	
Error code	Description
201	Indoor unit quantity setting error. Indoor unit quantity setting on MAIN outdoor unit PCB does not match installed/found indoor unit quantity. Duplicate indoor unit addresses can also cause this. Occurs after 5 tracking attempts.
202	System shutdown by communication error.
203	Communication error between MAIN and SUB outdoor units.
204	MCU quantity setting error. MCU unit quantity setting on MAIN outdoor unit PCB does not match installed/found MCU quantity. Occurs after 5 tracking attempts.
205	Communication error between micro-processors of inverter PCB and fan motor PCB.
206	Communication error between MAIN and SUB PCB's.

E210 .. 220: MCU	
Error code	Description
210	MCU communication error. There is no communication for 2 minutes between outdoor unit and MCU(s).
211	An indoor unit is connected to two MCU ports that are not consecutive (consecutive example: Port A/B, C/D, E/F). An indoor unit address is set for 2 ports that are not consecutive.
212	Duplicate indoor unit address set on an MCU (more than three).
213	Assigned indoor unit address does not exist on an MCU PCB. An indoor unit address has not been set on an MCU.
214	Specified quantity of MCUs on the outdoor unit PCB does not match installed MCU quantity OR MCU address overlap - duplicate MCU addresses on a system.
215	Duplicate indoor unit address on multiple MCU's (an indoor unit can only connect to a single MCU).
216	MCU port enabled when indoor unit is not actually connected. Dip switch ON status on MCU even though indoor unit is not connected.
217	MCU port disabled when indoor unit is actually connected. Dip switch OFF status on MCU even though indoor unit is connected.
218	Number of indoor units connected to an MCU does not match with assigned number in MCU. Connected indoor unit quantity does not match enabled port quantity on an MCU.
219	Subcooler inlet temperature sensor in MCU is open/short.
220	Subcooler outlet temperature sensor in MCU is open/short.
220	Subcooler outlet temperature sensor in MCU is open/short.
220	Subcooler outlet temperature sensor in MCU is open/short.

E221 .. 400: Sensor error - Outdoor unit	
Error code	Description
221	Ambient temperature sensor in the outdoor unit is open/short. ERROR LEVEL: more than 4.9V (-50°C, -58°F), less than 0.4V (93°C, 199.4 °F)
224	Water temperature sensor is open/short.
225	Control box temperature sensor is open/short (water cooled DVM Water and DVM S Water outdoor units).
226	Outdoor unit ambient temperature sensor has separated or has been removed from its designed location.
231	Condenser outlet (COND_OUT) temperature sensor of MAIN outdoor unit is open/short. ERROR LEVEL: more than 4.9V (-50°C, -58°F), less than 0.4V (93°C, 199.4°F)
236	Condenser outlet (COND_OUT) temperature sensor of SUB1 outdoor unit is open/short. ERROR LEVEL: more than 4.9V (-50°C, -58°F), less than 0.4V (93°C, 199.4°F). In case of DVM S, COND OUT2 TEMP SENSOR ERROR (OPEN/SHORT)
237	Outdoor unit condenser outlet temperature sensor has separated or has been removed from its designed location. ERROR LEVEL: more than 4.9V (-50°C, -58°F), less than 0.4V (93°C, 199.4°F)
241	Condensing temperature sensor (COND_MID or COND_OUT) on the condenser has separated from the coil/pipe.
242	Heater error in the outdoor unit.
246	Condensing temperature sensor (COND_OUT 1) on the condenser has separated from the coil/ pipe. In case of DVM S, COND OUT2 sensor has separated from the coil/pipe
247	Subcooling Liquid temperature sensor of MAIN outdoor unit is open/short. ERROR LEVEL: more than 4.9V (-50°C, -58°F), less than 0.4V (93°C, 199.4°F)
251	Discharged gas temperature sensor in variable speed is open/short. This function only activates when ambient temperature > -10°C (14°F). ERROR LEVEL: more than 4.9V (-30°C, -22°F), less than 0.4V (151°C, 308°F)
256	Discharged gas temperature sensor in fixed speed compressor 1 is open/short. This function only activates when ambient temperature > -10°C (14°F). ERROR LEVEL: more than 4.9V (-30°C, -22°F), less than 0.4V (151°C, 308°F)
257	Discharged gas temperature sensor in fixed speed compressor 2 is open/short. This function only activates when ambient temperature > -10°C (14°F). ERROR LEVEL: more than 4.9V (-30°C, -22°F), less than 0.4V (151°C, 308°F)
258	Discharged gas temperature sensor in fixed speed compressor 3 is open/short. This function only activates when ambient temperature > -10°C (14°F). ERROR LEVEL: more than 4.9V (-30°C, -22°F), less than 0.4V (151°C, 308°F)
261	Discharge temperature sensor in variable speed compressor has separated from the pipe.
262	Discharge temperature sensor in the first fixed speed compressor has separated from the pipe.
263	Discharge temperature sensor in the second fixed speed compressor has separated from the pipe.
264	Discharge temperature sensor in the third fixed speed compressor has separated from the pipe.
265	SUMP temperature sensor in variable (MAIN) unit has separated from the compressor. This temperature sensor located on the base (bottom) line of the compressor.
266	SUMP temperature sensor in the first fixed capacity (SUB1) unit has separated from the compressor. This temperature sensor located on the base (bottom) line of the compressor.
267	SUMP temperature sensor in the second fixed capacity (SUB2) unit has separated from the compressor. This temperature sensor located on the base (bottom) line of the compressor.

E221 .. 400: Sensor error - Outdoor unit	
Error code	Description
268	SUMP temperature sensor in the third fixed capacity (SUB3) unit has separated from the compressor. This temperature sensor located on the base (bottom) line of the compressor.
269	Suction temperature sensor in outdoor unit has come separated from the pipe.
270	Suction2 temperature sensor in outdoor unit has come separated from the pipe.
271	SUMP temperature sensor in variable compressor is open/short. This function only activates when ambient temperature > -10°C (14°F). ERROR LEVEL: more than 4.9V (-30°C, -22°F), less than 0.4V (151°C, 308°F)
272	Suction3 temperature sensor in outdoor unit has come separated from the pipe.
276	SUMP temperature sensor in the first fixed speed compressor is open/short. This function only activates when ambient temperature > -10°C (14°F). ERROR LEVEL: more than 4.9V (-30°C, -22°F), less than 0.4V (151°C, 308°F)
277	SUMP temperature sensor in the second fixed speed compressor is open/short. This function only activates when ambient temperature > -10°C (14°F). ERROR LEVEL: more than 4.9V (-30°C, -22°F), less than 0.4V (151°C, 308°F)
278	SUMP temperature sensor in the third fixed speed compressor is open/short. This function only activates when ambient temperature > -10°C (14°F). ERROR LEVEL: more than 4.9V (-30°C, -22°F), less than 0.4V (151°C, 308°F)
286	Mid pressure sensor short/open error.
291	High pressure sensor is open/short. This function only activates at compressor startup. ERROR LEVEL: SHORT: less than 0.4V, error detect. OPEN error: over 4.2V, error detect.
296	Low pressure sensor is open/short. This function only activates at compressor startup. ERROR LEVEL: SHORT: less than 0.4V, error detect. OPEN error: over 4.2V, error detect.
301	High pressure sensor in outdoor unit has separated or has been removed from its designed location.
306	Low pressure sensor in outdoor unit has separated or has been removed from its designed location.
307	Oil balancing temperature sensor is open/short.
308	Suction temperature sensor is open/short.
309	Oil balancing temperature sensor #2 is open/short.
310	Oil balancing temperature sensor #3 is open/short.
311	Temperature sensor error of subcooler temperature sensor in DVM PLUS 2 (open/short).
312	Main cooling solenoid valve is opened in HR outdoor unit.
313	Reversing (4 way) valve operating error.
315	CT (Current) sensor #1 is open/short.
316	CT (Current) sensor #2 is open/short.
317	CT (Current) sensor #3 is open/short.
320	OLP (Over Load Protection) sensor #3 is open/short.
321	EVI EEV inlet temperature sensor is open/short. EVI EEV: Electronic Expansion Valve for Vapor injection or subcooler
322	EVI EEV outlet temperature sensor is open/short. EVI EEV: Electronic Expansion Valve for Vapor injection or subcooler
324	Fan motor #1 current sensor in outdoor unit is open/short.

E221 .. 400: Sensor error - Outdoor unit	
Error code	Description
325	Fan motor #2 current sensor in outdoor unit is open/short.
326	ERROR_ID_TOTAL_SUCTION_SENSOR
330	Inlet temperature sensor (TA_0) of port #0 in FJM outdoor unit has separated from the pipe.
331	Inlet temperature sensor (TA_1) of port #1 in FJM outdoor unit has separated from the pipe.
332	Inlet temperature sensor (TA_2) of port #2 in FJM outdoor unit has come separated from the pipe.
333	Inlet temperature sensor (TA_3) of port #3 in FJM outdoor unit has separated from the pipe.
334	Inlet temperature sensor (TA_4) of port #4 in FJM outdoor unit has separated from the pipe.
335	Outlet temperature sensor (TB_0) of port #0 in FJM outdoor unit has separated from the pipe.
336	Outlet temperature sensor (TB_1) of port #1 in FJM outdoor unit has separated from the pipe.
337	Outlet temperature sensor (TB_2) of port #2 in FJM outdoor unit has separated from the pipe.
338	Outlet temperature sensor (TB_3) of port #3 in FJM outdoor unit has separated from the pipe.
339	Outlet temperature sensor (TB_4) of port #4 in FJM outdoor unit has separated from the pipe.
346	Failure to start fan motor #2.
347	Fan motor #2 is not connected.
348	Fan motor #2 is locked.
353	Overheating error in outdoor fan motor #2.
355	IPM (Internal PCB Module) overheating error in outdoor fan motor #2
361	Failure to start inverter compressor #2.
364	"DC Peak" error. Inverter compressor #2 stopped due to "DC Peak".
365	Inverter compressor #2 stopped due to overcurrent (Over 30A)
366	Voltage in DC Link is below 150V or over 410V
367	Abnormal RPM in inverter compressor #2. Wire for compressor has not been connected.
368	Current sensor error in inverter compressor #2.
369	DC Link sensor error in inverter #2 PCB.
371	Inverter 2 outdoor unit EEPROM Read/Write error (OTP error)
374	Temperature sensor error in inverter PCB #2 heatsink
378	Outdoor fan 2 IPM H/W OC
385	Incoming-current sensor error in inverter PCB #2.
387	"Hall" sensor (RPM sensor) in outdoor fan motor #2.
388	Incoming-voltage sensor error in inverter PCB #2.
389	Fan motor #2 stopped due to overload
391	Fan controller 2 EEPROM Read/Write error
393	Current sensor error in fan motor controller #2
396	DC Link sensor error in fan motor controller #2
399	Temperature sensor error in fan motor controller #2 heatsink.
400	IGBT module in inverter PCB #2 overheat error.

E401 .. 550: Protection control / detection error - Outdoor unit	
Error code	Description
401	Outdoor freezing detection 1.
402	Outdoor freezing detection 2.
403	Outdoor freezing detection 3, compressor down.
407	Compressor stopped due to high pressure control (protection control 1).
408	Compressor stopped due to high pressure control (protection control 2).
409	Compressor stopped due to high pressure control (protection control 3).
410	Compressor operation stopped due to low pressure protection control or refrigerant leakage (protection control 1).
411	Compressor operation stopped due to low pressure protection control or refrigerant leakage (protection control 2).
412	Compressor operation stopped due to low pressure protection control or refrigerant leakage (protection control 3).
413	Protection control by sump sensor.
414	Protection control by sump sensor 2.
415	Protection control by sump sensor 3.
416	Compressor operation stop due to discharge temperature protection control. Discharge temperature protection control for first compressor in outdoor unit.
417	Discharge temperature protection control for second compressor in outdoor unit.
418	Discharge temperature protection control for third compressor in outdoor unit.
419	EEV #1 in the outdoor unit cannot close fully (sixth detection)
420	EEV #2 in the outdoor unit cannot close fully (sixth detection)
421	EEV #3 in the outdoor unit cannot close fully (sixth detection)
422	EEV #1 in the outdoor unit cannot open fully (sixth detection)
423	EEV #2 in the outdoor unit cannot open fully (sixth detection)
424	EEV #3 in the outdoor unit cannot open fully (sixth detection)
425	Reverse phase or missing phase of 3 phase field power supply (first detection).
426	Reverse phase or missing phase of 3 phase field power supply (first detection).
427	Reverse phase or missing phase of 3 phase field power supply (first detection).
428	Compressor operation stopped due to abnormal compression ratio - Error 1
429	Compressor operation stopped due to abnormal compression ratio - Error 2
430	Compressor operation stopped due to abnormal compression ratio - Error 3
431	Malfunction of first oil balancing solenoid valve
432	Malfunction of second oil balancing solenoid valve
433	Malfunction of third oil balancing solenoid valve
434	Oil balancing valve is opened. Hot gas bypass valve is opened (DVM PLUS 2)
435	Flow switch error in water cooled DVM Water and DVM S Water outdoor units
436	System protection error to prevent equipment damage/pipe burst due to frozen pipes.
437	Oil balancing valve is closed. Hot gas bypass valve is closed: DVM PLUS 2
438	EVI EEV (Vapor Injection / Subcooler Electronic Expansion Valve) cannot close fully.
439	Refrigerant leak error. Abnormal low/high pressure before starting.

E401 .. 550: Protection control / detection error - Outdoor unit	
Error code	Description
440	[Protection control] System will not operate in heating mode because ambient temperature is over 30°C (86°F).
441	[Protection control] System will not operate in cooling mode because ambient temperature is too low.
442	[Protection control] System will not operate in heating and refrigerant charging function because ambient temperature is over 30°C (86°F).
443	Refrigerant leak error.
445	Crank Case Heater (CCH) error - CCH malfunction or Top/Sump Sensor not connected/separated.
446	Failure to start fan motor #1 in outdoor unit.
447	Fan motor #1 is not connected in outdoor unit.
448	Fan motor #1 is locked in outdoor unit.
449	Compressor stopped due to mid pressure protection control.
450	Error due to high condensing temperature.
451	Low pressure switch error. Low pressure switch is activated.
452	Error due to power supply blackout (instant power off) OR outdoor unit zero crossing error.
453	Outdoor fan motor overheating error.
454	Outdoor fan motor RPM error
455	Outdoor fan motor IPM (Internal PCB Module) overheating error.
456	Outdoor fan motor overcurrent error.
457	Outdoor fan error due to reverse fan direction caused by wind.
458	Fan motor locking error or overcurrent in CT1 (current sensor 1).
459	IPM (Internal PCB Module) fault or overcurrent in CT2 (current sensor 2).
460	Cross wiring error (communication / power supply) or overcurrent error in CT3 (current sensor 3).
461	Failure to start compressor or low current at CT1 (current sensor 1).
462	Compressor stopped due to current control (low current at CT2).
463	Compressor stopped due to OLP temperature (Over Load Protection) or low current at CT3
464	Error due to over-current of inverter compressor 1. Compressor stopped due to overcurrent (DC Peak)
465	V-limit error of inverter compressor 1. Compressor stopped due to overcurrent (Over 30A).
466	Voltage in DC Link is below 150V or over 410V
467	Abnormal RPM in inverter compressor #1. Wire for compressor has not been connected.
468	Current sensor error in inverter compressor #1.
469	DC Link sensor error in inverter #1.
470	Outdoor unit EEPROM read or write error.
471	Read or write error of EEPROM in outdoor (OTP error).
472	Outdoor unit zero crossing error
473	Locking error of inverter compressor.
474	Heat sink temperature sensor error of inverter PBA1

E401 .. 550: Protection control / detection error - Outdoor unit	
Error code	Description
475	Outdoor fan motor #2 error OR outdoor fan motor #2 RPM error (more than 2500 RPM and the difference of target velocity compared with practical velocity is more than 100 RPM per 10 seconds, more than 10 times).
476	Reversing (4 way) valve malfunction.
477	Protection control - protect compressor from backflow of liquid refrigerant.
478	Outdoor Fan IPM H/W OC
479	Crossed/reversed wiring or connector in reversing (4 way) valve.
480	OLP protection control, refrigerant leaks
481	Compressor #1 failed to start.
482	Compressor #2 failed to start.
483	Overvoltage in DC Link (H/W, S/W)
484	Overcurrent in PFC
485	Error due to input current of inverter 1. Incoming-current sensor error.
486	Error due to over voltage/low voltage of fan motor
487	Hall sensor (RPM sensor) in outdoor fan motor #2.
488	Incoming-voltage sensor error
489	Outdoor unit fan motor stopped due to overload (V-limit)
490	[Protection control] Prohibition to operate when ambient temperatures are below 0°C (32°F)
491	Read or write error of EEPROM in fan motor controller.
492	Outdoor Fan 2 IPM H/W OC
493	Current sensor error in fan motor controller #1
494	Delayed time error due to locked outdoor fan motor #2
495	Fan motor #2 overheat error
496	DC Link sensor error in fan motor controller #1
497	Fan motor #2 overcurrent error
498	Outdoor fan #2 IPM (Internal PCB Module) overheating error
499	Temperature sensor error in fan #1 motor controller heatsink.
500	IGBT module in inverter PCB #1 overheat error.
503	Error due to liquid or gas service valve being closed.
504	Compressor failed to start. Error due to self diagnosis of compressor operation.
505	High pressure sensor error (self-diagnosis)
506	Low pressure sensor error (self-diagnosis)
507	DC high pressure switch open.
508	Smart Install could not be performed.
509	Smart Install could not be completed because this Outdoor is failed by error.
510	Smart Install could not be completed because this Indoor is failed by error.
515	Overheated control box (DVM Water outdoor units)
516	Control box heatsink fan motor locked (DC fan in water cooled DVM Water and DVM S water outdoor units)
520	Inverter PBA Fault

E401 .. 550: Protection control / detection error - Outdoor unit	
Error code	Description
521	Inverter Manual Check
522	Inverter #2 PBA Fault
523	Inverter #2 Manual Check
524	Fan controller #1 PBA Fault
525	Fan controller #1 Manual Check
526	Fan controller #2 PBA Fault
527	Fan controller #2 Manual Check
534	Error due to over-current of inverter compressor 1. Compressor stopped due to overcurrent (DC Peak) (Heat Mode)
535	V-limit error of inverter compressor 1. Compressor stopped due to overcurrent (Over 30A). (Heat Mode)

E551 .. 600: ETC - Outdoor unit	
Error code	Description
551	[Operation] Defrost operation is being performed.
552	Compressor discharge gas pressure is low.
553	equability operation
554	Loading failure / total refrigerant leakage from outdoor unit.
555	[Operation] Oil return operation (the recovery of accumulated oil inside pipes and indoor units)
556	Configuration error due to outdoor capacity.
557	During DPM mode, discordant basic product options between indoor units error
559	Indoor unit(s) stopped due error in outdoor unit
560	Switch option setting error(not applied)
561	Outdoor unit SA(SUPPLY AIR) FAN RPM
562	Outdoor unit RA(ROOM AIR) FAN RPM
563	Error due to indoor unit software version combination (incompatible indoor unit software on a system)
565	Connection error between compressor and power wire. Power line of Eva1 connected to compressor #2 or power line of Eva2 connected with compressor #1.
570	Boot code check failure.
573	Error due to using single type outdoor unit in a module installation.
574	Total leakage of refrigerant - outdoor unit #2
575	Total leakage of refrigerant - outdoor unit #3
590	Communication error in Inverter driver #1
591	Communication error in Inverter driver #2
592	Communication error in Inverter driver #3
593	Communication error in Inverter driver #4
594	Communication error in fan motor driver #1
595	Communication error in fan motor driver #2
596	Communication error in fan motor driver #3

E601 .. 650: Option device error	
Error code	Description
601	Communication error between wired remote controller and indoor unit after successful communication (wired controller error).
602	No communication between MASTER (main) and SLAVE (sub) wired remote controllers.
603	communication packet error (Baudrate)
604	No communication between wired remote controller and indoor unit(s).
605	7 Day Scheduler - wired remote controller \n CAUR communication error
606	Error of mismatching COM1/COM2(wired remote controller)
607	Error of setting option switch for master(wired remote controller)
608	Cannot detect ERV controller.
609	Error of setting optional external controller
610	CAUR - TRANS Communication Error
611	CAUR Communication Error
612	PEAK Communication Error
613	Communication error between DMS and PIM/SIM. (PIM: Power Interface Module, SIM: Signal Interface Module)
614	Communication error between power meter and PIM/SIM (PIM: Power Interface Module. SIM: Signal Interface Module)
615	Communication error between IM (interface module) and indoor units. No communication response for 2 minutes from a specific indoor unit after tracking has been completed
616	Communication error between IM (interface module) and outdoor unit. No communication response for 2 minutes from an outdoor unit after tracking has been completed.
617	Communication error between Peak current transmitter - Demand Controller, Communication error between Demand transmitter - Watt-hour meter
618	Wired controller error - more than 16 units are connected to a controller (maximum: 16).
619	Temperature display error from indoor unit connected with new wire LCD - mismatched units of measure (Fahrenheit/Celsius) on same system. Occurs when wired controllers and indoor units are configured for Fahrenheit and Celsius on the same system (F1/F2).
620	Mismatched units of measure (Fahrenheit/Celsius) on same system. Dip switch #4 setting error.
621	New Wire remote controller Master/Slave dip switch option set error (1 Master and 1 Slave must be specified when connected to same F3/F4 connection).
622	Error of selecting the Watt-hour meter/Demand Controller way
623	Error of unsetting Demand transmitter PT / CT
624	Error of receiving over-value data from the Watt-hour meter of Demand transmitter
625	Master DMS to Slave DMS communication error
626	ERV remote controller (AWR-WE00) error. Occurs when only ERV's are connected to AWR-WE00 and AWR-AH10 controllers without indoor unit(s) (ERV only connection).
627	Two or more wired remote controller set as SLAVE (sub) wired controller error
628	DMS to transmitter (interface module) communication error
629	DMS DDC communication error
630	ERV wired controller normal ventilation option set error. Check normal ventilation option set only. ERV normal ventilation no option, use wired controller option normal ventilation.

E601 .. 650: Option device error	
Error code	Description
631	ERV wired controller auto ventilation option set error. Check set auto ventilation only. ERV auto ventilation not an option, use wired controller auto ventilation.
632	Pulse input error - The pulse width input is different than what is specified in PIM (MIM-B16, MIM-B16N). Pulse width is less than 20ms, over 400ms, over range of set pulse width, or repeated pulse over 3min.
634	Converter address setting error

E652 .. 700: ETC	
Error code	Description
652	Error of setting option switch for COM 1 Dual Master
653	Temperature sensor is open/short.
654	ERV damper error.
657	K1Filter3 Feedback Error
659	Illumination Sensor Error
660	BOOT CODE Error
661	Water could not be supplied because the supply pump is failed by error
662	Water could not be circulated because the circulation pump is failed by error
663	Water could not be drained because the drain pump is failed by error
664	The sterilization electrode is not working due to error
665	External Device Error State
687	2nd refrigerant leak detection error from an MCU or SVB unit
696	1st refrigerant leak detection error
697	2nd refrigerant leak detection error from an indoor unit
698	Refrigerant leak sensor failure error
699	Refrigerant leak sensor replacement notification error
700	Refrigerant leak sensor lifetime expiration error

E701 .. 800: Protection control low level risk	
Error code	Description
701	Indoor unit condensate float switch error - first detection
702	EEV (Electronic Expansion Valve) in the indoor unit cannot open fully/properly (first detection)
703	EEV (Electronic Expansion Valve) in the indoor unit cannot close fully/properly (first detection).
720	EEV (Electronic Expansion Valve) #1 in the outdoor unit is opened (self-diagnosis).
721	EEV (Electronic Expansion Valve) #2 in the outdoor unit is opened (self-diagnosis).
722	EEV (Electronic Expansion Valve) #3 in the outdoor unit is opened (self-diagnosis).
723	EEV (Electronic Expansion Valve) #1 in the outdoor unit is closed (self-diagnosis).
724	EEV (Electronic Expansion Valve) #2 in the outdoor unit is closed (self-diagnosis).
725	EEV (Electronic Expansion Valve) #3 in the outdoor unit is closed (self-diagnosis).

E801 .. 900: Protection control low level risk	
Error code	Description
801	[GHP-R410A] Communication error: "IF → Outdoor unit": Wire breaking
802	[GHP-R410A] Communication error: "Outdoor unit → IF": Wire breaking
803	[GHP-R410A] Communication error: Wires of some indoor units are broken in "IF - Indoor unit" (during communication)
804	[GHP-R410A] communications error: communications error between outdoor units
805	[GHP-R410A] abnormal outdoor unit organization setup
806	[GHP-R410A] Remote controller sensor wire breaking/short:
807	[GHP-R410A] Outdoor liquid pipe sensor wire breaking/short:
808	[GHP-R410A] Outdoor Unit ?Short/Wire breaking of overcooling heat exchanging entry temperature Thermist
809	[GHP-R410A] Over-rise of compressor inhalation temperature
810	[GHP-R410A] No rise of compressor inhalation temperature
811	[GHP-R410A] Refrigerant high pressure switch wire breaking
812	[GHP-R410A] Gas Solenoid valve output error:
813	[GHP-R410A] Refrigerant low pressure sensor error (2nd)
814	[GHP-R410A] Refrigerant high pressure sensor error 1
815	[GHP-R410A] Refrigerant high pressure sensor error 2 (High sensor value is lower than the specified low pressure)
816	[GHP-R410A] Water pump operation failed
817	[GHP-R410A] Error of the number of Water pump rotations
818	[GHP-R410A] IPM (Outdoor Fan operation driver) error
819	[GHP-R410A] Outdoor heat exchanging fan 1 operation failed
820	[GHP-R410A] Outdoor heat exchanging fan 2 operation failed
821	[GHP-R410A] Outdoor heat exchanging fan 3 operation failed
822	[GHP-R410A] Error of the number of Outdoor heat exchanging fan 1 rotations
823	[GHP-R410A] Error of the number of Outdoor heat exchanging fan 2 rotations
824	[GHP-R410A] Error of the number of Outdoor heat exchanging fan 3 rotations
825	[GHP-R410A] Outdoor Unit ?Bad heat exchanging fan rotation
826	[GHP-R410A] Outdoor Unit ?Short/Wire breaking of Accum exit temperature thermist 1
827	[GHP-R410A] Outdoor Unit ?Short/Wire breaking of Accum exit temperature thermist 2
828	[GHP-R410A] Outdoor Unit ?Short/Wire breaking of refrigerant low pressure switch
829	[GHP-R410A] Refrigerant low pressure error
830	[GHP-R410A] 3-phase power error
831	[GHP-R410A] Single-phase power part error
832	[GHP-R410A] Main - Sub MICOM Program Version Unmatch
833	[GHP-R410A] Too many indoor units are connected
834	[GHP-R410A] Capacity of available indoor unit connection is over
835	[GHP-R410A] Unmatch of connection between outdoor-indoor
836	[GHP-R410A] Outdoor unit ?regular check
837	[GHP-R410A] Refrigerant high pressure error 1

E801 .. 900: Protection control low level risk	
Error code	Description
838	[GHP-R410A] Refrigerant high pressure error 2
841	[GHP-R410A] outdoor heat bridge gas temperature thermistor disconnected/short circuit
842	[GHP-R410A] Engine Room temperature sensor wire breaking/short:
843	[GHP-R410A] Engine water-temperature sensor wire breaking/short:
844	[GHP-R410A] Engine evacuation temperature sensor wire breaking/short:
845	[GHP-R410A] Engine oil pressure error
846	[GHP-R410A] Engine oil pressure switch wire breaking
847	[GHP-R410A] Engine overrotation 1
848	[GHP-R410A] Engine overrotation 2
849	[GHP-R410A] Starter Malfunction
850	[GHP-R410A] Engine rotation number control error
851	[GHP-R410A] Engine Stop
852	[GHP-R410A] Low voltage of IGUNAITA (igniter)
853	[GHP-R410A] Wire breaking of IGUNAITA (igniter)
854	[GHP-R410A] Overvoltage of IGUNAITA (igniter)
855	[GHP-R410A] Engine evacuation temperature error
856	[GHP-R410A] Engine water-temperature overrise
857	[GHP-R410A] Engine running failed
858	[GHP-R410A] No coolant in Engine
859	[GHP-R410A] The number of Engine running rotations is insufficient
860	[GHP-R410A] Engine rotation number haunting error
861	[GHP-R410A] Over-rise of compressor discharge temperature
862	[GHP-R410A] Short/wire-breaking of compressor discharge temperature sensor 1
863	[GHP-R410A] Short/wire-breaking of compressor discharge temperature sensor 2
864	[GHP-R410A] Short/wire-breaking of compressor discharge temperature sensor 3
865	[GHP-R410A] Short/wire-breaking of compressor discharge temperature sensor 4
866	[GHP-R410A] Short/wire-breaking of compressor inhalation temperature sensor 1
867	[GHP-R410A] Short/wire-breaking of compressor inhalation temperature sensor 2
868	[GHP-R22] Outdoor Unit ?Short/Wire breaking of Accum entry temperature sensor
869	[GHP-R22] Outdoor Unit ?Short/Wire breaking of refrigerant gas pipe temperature sensor
870	[GHP-R22] Outdoor Unit ?Lack of lubricant in compressor
871	[GHP-R22] Outdoor Unit ?Error of overcharged refrigerant
872	[GHP-R22] Outdoor Unit ?Error of compressor inhalation temperature
873	[GHP-R22] Coolant meter error
874	[GHP-R22] Engine oil meter error
875	[GHP-R22] Engine powermeter error
876	[GHP-R22] Engine starting meter/control meter error
880	[GHP-R410A] outdoor unit - no increase in engine refrigerant temperature
881	[GHP-R410A] outdoor unit - engine oil leak

E801 .. 900: Protection control low level risk	
Error code	Description
882	[GHP-R410A] outdoor unit - no refrigerant oil
883	[GHP-R410A] outdoor unit - starter transformer voltage disconnected
884	[GHP-30HP-F-Model] Outdoor unit - engine misfire (1st cylinder)
885	[GHP-30HP-F-Model] Outdoor unit - engine misfire (2nd cylinder)
886	[GHP-30HP-F-Model] Outdoor unit - engine misfire (3rd cylinder)
887	[GHP-30HP-F-Model] Outdoor unit - engine misfire (4th cylinder)
898	Mismatch Error between Commkit and Outdoor
899	Zone1 Water Outlet Sensor(Tw2_Z1) is open/short
900	Zone2 Water Outlet Sensor(Tw2_Z2) is open/short

E901 .. 920: EHS error	
Error code	Description
901	Supply water temperature sensor (Tw1) in PHE is open/short (PHE: Plate Heat Exchanger in water cooled unit).
902	Leaving water temperature sensor (Tw3) in PHE is open/short (PHE: Plate Heat Exchanger in water cooled unit).
903	PHE Sensor (Tw2) is open/short (PHE: Plate Heat Exchanger in water cooled unit).
904	Water tank sensor is open/short.
905	Solar sensor is open/short.
906	Outdoor EVA In sensor SHORT/OPEN
907	Error due to pipe rupture protection.
908	Compressor stopped due to "Freezing protection control"
909	Compressor stopped and will not operate again due to 'Freezing protection control (third detection)'
910	Water outlet (TW2) temperature sensor has separated from the pipe.
911	Water flow switch "Open" Error
912	Water flow switch "Close" Error
913	System will not restart because "Water flow switch error" has been detected 6 times.
914	Cross wiring / reversed connection in "Thermostat"
915	DC fan motor is not operating (water cooled DVM Water and DVM S Water outdoor units).
916	Mixing sensor is open/short.
917	Master setting error for sharing WaterTank sensor value(Master one or more / no installed by Master)
918	ERROR_ID_CHILLER_PUMP_INTERLOCK_INPUT
919	Not completed the disinfection mode.
920	FSV SD Data Read Fail

E921 .. 970: AHU error	
Error code	Description
921	System error
922	Fire alert
923	SA fan alert
924	RA fan alert
925	EA damper error
926	MA damper error
927	OA damper error
928	Static pressure sensor error
929	Air flow error
932	RA temperature sensor error
933	RA humidity sensor error
934	SA temperature sensor error
935	SA humidity sensor error
936	OA temperature sensor error
937	OA humidity sensor error
938	MA temperature sensor error
941	Heater overheated
942	Heater valve
943	Humidifier overheated
944	Humidifier valve
945	Water level error
946	Supply water error
947	Drain water error
948	CO2 sensor error
951	High RA temperature alert
952	Low RA temperature alert
953	High RA humidity alert
954	Low RA humidity alert
955	High SA temperature alert
956	Low SA temperature alert
957	High SA humidity alert
958	Low SA humidity alert
959	High OA temperature alert
960	Low OA temperature alert
961	High OA humidity alert
962	Low OA humidity alert
963	High MA temperature alert
964	Low MA temperature alert

E971 .. 999: DVM Chiller / FCU error	
Error code	Description
971	External sensor (WaterOut Setting Device/WaterLaw Room Temp sensor) is open/short.
972	Water inlet side pressure sensor is open/short.
973	Water outlet side pressure sensor is open/short
974	External WaterOut sensor is open/short.
990	Water-In1 sensor is open/short
991	Water-In2 sensor is open/short
992	When Cooling Operation, Water-In1 temperature sensor has separated from the pipe/coil or the water flow blockage has detected
993	When Heating Operation, Water-In2 temperature sensor has separated from the pipe/coil or the water flow blockage has detected
998	Bluetooth Paring Error